

ADVERTIMENT. La consulta d'aquesta tesi queda condicionada a l'acceptació de les següents condicions d'ús: La difusió d'aquesta tesi per mitjà del servei TDX (www.tesisenxarxa.net) ha estat autoritzada pels titulars dels drets de propietat intel·lectual únicament per a usos privats emmarcats en activitats d'investigació i docència. No s'autoritza la seva reproducció amb finalitats de lucre ni la seva difusió i posada a disposició des d'un lloc aliè al servei TDX. No s'autoritza la presentació del seu contingut en una finestra o marc aliè a TDX (framing). Aquesta reserva de drets afecta tant al resum de presentació de la tesi com als seus continguts. En la utilització o cita de parts de la tesi és obligat indicar el nom de la persona autora.

ADVERTENCIA. La consulta de esta tesis queda condicionada a la aceptación de las siguientes condiciones de uso: La difusión de esta tesis por medio del servicio TDR (www.tesisenred.net) ha sido autorizada por los titulares de los derechos de propiedad intelectual únicamente para usos privados enmarcados en actividades de investigación y docencia. No se autoriza su reproducción con finalidades de lucro ni su difusión y puesta a disposición desde un sitio ajeno al servicio TDR. No se autoriza la presentación de su contenido en una ventana o marco ajeno a TDR (framing). Esta reserva de derechos afecta tanto al resumen de presentación de la tesis como a sus contenidos. En la utilización o cita de partes de la tesis es obligado indicar el nombre de la persona autora.

WARNING. On having consulted this thesis you're accepting the following use conditions: Spreading this thesis by the TDX (www.tesisenxarxa.net) service has been authorized by the titular of the intellectual property rights only for private uses placed in investigation and teaching activities. Reproduction with lucrative aims is not authorized neither its spreading and availability from a site foreign to the TDX service. Introducing its content in a window or frame foreign to the TDX service is not authorized (framing). This rights affect to the presentation summary of the thesis as well as to its contents. In the using or citation of parts of the thesis it's obliged to indicate the name of the author



REFURBISHMENT SCENARIOS FOR POST-WAR INDUSTRIALIZED HOUSING IN BEOGRAD

PhD Thesis 2015
UPC

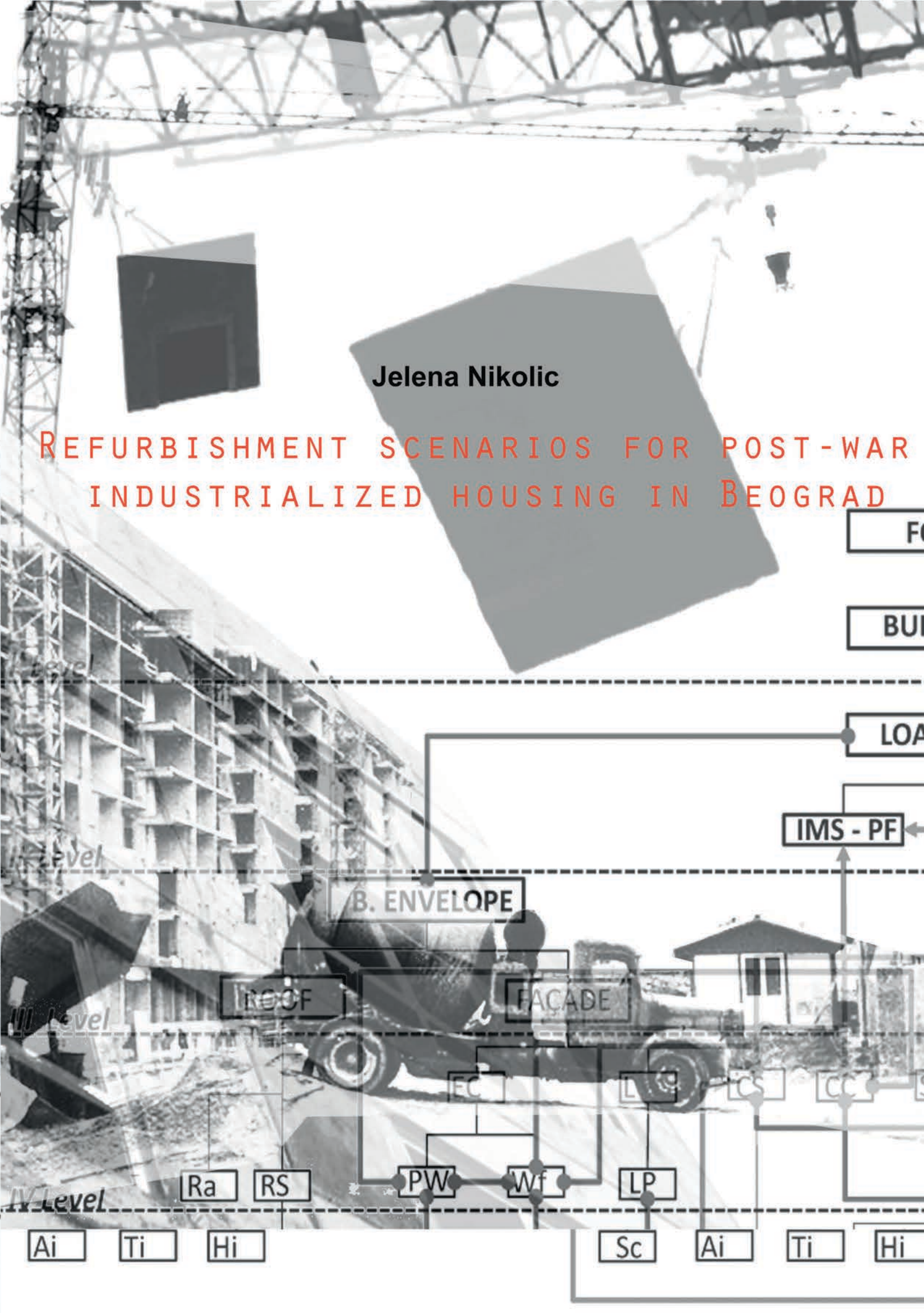

Jelena Nikolic

REFURBISHMENT SCENARIOS FOR POST-WAR INDUSTRIALIZED HOUSING IN BEOGRAD

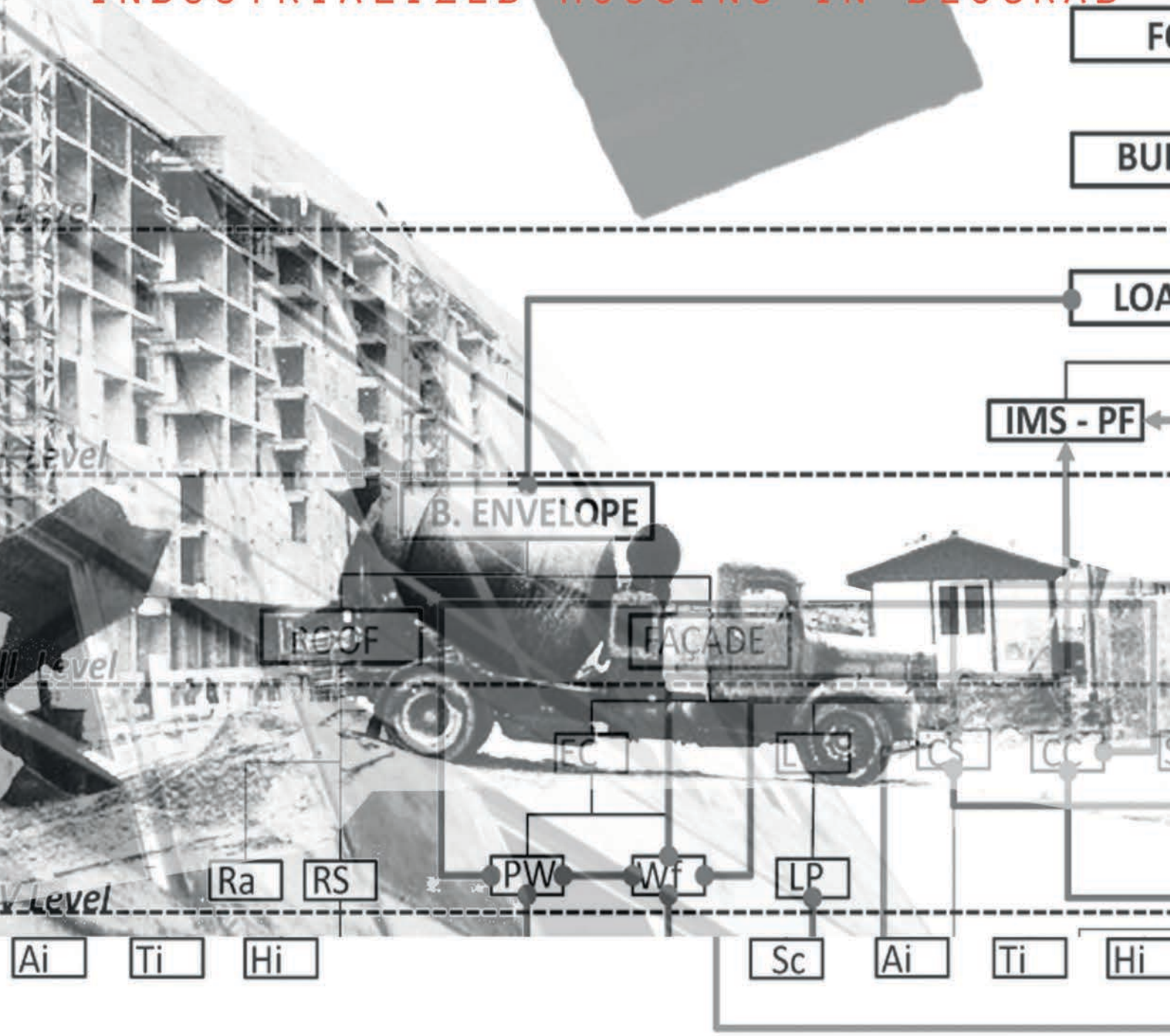



UNIVERSITAT POLITÈCNICA DE CATALUNYA

PhD program: ARCHITECTURE TECHNOLOGY, CONSTRUCTION AND URBANISM

PhD THESIS

**Refurbishment scenarios for post-war industrialized
housing in Beograd**



THESIS SUBMITTED TO THE FACULTY OF ARCHITECTURE POLYTECHNIC UNIVERSITY OF CATALONIA

FOR THE DEGREE OF

PhD Program

TECNOLOGÍA EN LA ARQUITECTURA, EDIFICACIÓN Y URBANISMO

Academic course: 2015-2016

Candidate

Jelena Nikolic

Thesis Supervisor

Josep I. de Llorens Duran

Copyright 2015, Jelena Nikolic

Abstract

The sustainability aspect of industrialized housing blocks is analyzed through the possibility of the Building Model (BM) to be upgraded (not demolished) on different levels of its composition. Flexible use and transformation capacity of BM may be a solution to convert massive housing into a more adaptable building. To provide a maximum of possibilities during the building lifespan, the flexibility issue needs to be analyzed on different levels of a building's composition. Integration of industrialized and prefabricated components, subsystems and systems into building models and joints technology will be analyzed to evaluate dependency conditions and, accordingly, the possibility for transformations. The research project questions the flexibility-in-use provided by an overcapacity in the building structure. A massive housing adaptation process results in an excessive use of resources while the extra capacity may remain unused during the building lifespan. Physical characteristics of the BM are of interest: construction system, systems assemblies, components, materials, and joints technology.

Keywords: massive housing, systems building, industrialized housing, building model, integrated prefabrication, transformation capacity, refurbishment scenario, Beograd.

Summary

Scientific justification for the thesis, the expected results of the research and practical application of the results

The industrialized housing of post-war residential architecture and its special form of *'integrated'* prefabrication between 1955 and 1985 in Beograd has been analyzed with special interest in the transformation capacity of these massive building models on spatial, technical and environmental levels for future retrofitting. The focal points of the research are industrialized post-war multi-unit housing buildings and their special form of prefabrication models based on integration of systems and components by simple joints. We call this integrated building models.

We start with the analysis of the structural configuration of the integrated prefabricated systems (large panel and skeleton system) and the typology of spatial schemes of the housing layout and we put into correlation the following: the required adaptability of industrialized buildings on spatial, technical and energy efficiency level and the technological rules and values of the Building Model (BM). Industrialized Building Model (BM) is the system configuration based on a assembly of prefabricated components and subsystems according to the independent functional and technical levels. Considering the level of the functional, structural and physical dependency in this type of configuration, as well as the evaluation of integrated prefabricated housing systems for spatial and technical transformations, we will establish the measure in which the new integrated strategies and technical solutions based on simple and demountable dry joints, low energy incomes, sustainable materials and construction technology innovations are suitable for refurbishment of massive housing.

The author has limited the study to post-war housing built in Beograd between 1955 and 1985, which permitted a more in-depth study of the sample buildings, their configuration model and their systems. Moreover, the social housing built between 1945 and 1955 was discarded due to the fact that they didn't improve the sample as they were built in a conventional way.

Also, the author has limited the study to the technical and technological aspects of industrialized housing. The urban level has been put aside due to the fact that is another complex subject of Novi Beograd that emerged from the conflict between "the two dominant ideologies of the postwar period: the modernist, or CIAM's dogma of functional city and political, Marxist – socialist dogma, in the context of the ruling system."¹(Blagojevic, 2007). On the specific level, the future study will deal with the problem of the individuals, which is, in the case of both dominant ideologies, neglected and marginalized. Also, will be treated the problem of open, free spaces in Novi Beograd and their inert filling.

¹ Ljiljana Blagojevic, Novi Beograd: Osporeni modernizam (Beograd: Zavod za udzbenike, Arhitektonski fakultet Univerziteta uBeogradu, Zavod za zastitu spomenika culture grada Beograda, 2007), 244

This research started with four hypotheses:

- The industrialized technology and prefabricated construction techniques for post-war multi-unit housing in Belgrade would prove to be the only ones capable of producing these buildings within the time frame and budgetary constraints.
- Industrial models of post-war housing do have enough flexibility and can make transformations on functional, structural and energy efficiency level for total building upgrading.
- Industrialized system configurations based on integration of prefabricated systems and components for main building parts (load-bearing, enclosing, partitioning and building facilities) are flexible configurations. This means that they can be upgraded on different functional and technical levels (façade and load-bearing structure are independent assemblies).
- Feasibility to create the concepts / strategies / models and scenarios for the rehabilitation of massive housing on the structural, functional and environmental level. The optimization approach to the refurbishment of massive structures will lead to the integration of energy efficient systems.

These hypotheses have been corroborated in this project which consists of three main parts. First, the introduction to post-war industrialized housing architecture and main characteristics of “open” technology of prefabricated construction which was one of the countries' most successful products. Second, the current situation of post-war massive housing and its transformations as well as the main principles of the analysis of massive housing transformation capacity on different technical and functional levels. Third, the development of the integrated strategies for the massive housing rehabilitation process according to the principal value of flexible systems prefabrication.

Main criteria for the selection of case-study projects were: i) integrated prefabrication systems applied for building structures; ii) the variety of prefabricated construction techniques applied; iii) the heterogeneous housing types; iv) variety of dwelling schemes; v) variety of building envelope solutions.

This research allows the author to categorize the study content into three types of documents: i) a general study of more than 30 different Building Models in IMS, RAD-Balancy and Trudbenik prefabricated systems; ii) a detailed analysis of the most dominant construction systems used for post-war housing; iii) an in-depth study of the most representative integrated models built with each construction system. Following this categorization, the author presents her analysis which starts with a historical review of post-war industrialized housing in Beograd and with the emphasis on the connection details between prefabricated systems and components in the integrated building models. Also, the author analyzes the samples of a housing model and their composition applying a Graph Model for the evaluation of the transformations capacity of the existing massive blocks. The graph model is developed in order to describe the housing model of elements (components, components assemblies, subsystems and systems) as a diagram of relations. Its application is twofold: i) the transformation capacity analysis of massive structure system configuration; ii) the development of integrated, flexible and transformable (IFT) systems for housing refurbishment based on functional decomposition, controlled hierarchies and

demountable dry joints. This methodology has been successfully applied and is considered appropriate for use in other studies of massive prefabricated systems.

In the third section of this thesis we analyze integrated refurbishment strategies based on the results obtained by graphs analysis of more flexible node-cluster edges. The fourth section of this thesis presents the conclusions based on the analyses undertaken. According to these, the author provides some recommendations for the rehabilitation of prefabricated housing in the future. The proposals are based on rationality and they avoid subjective approaches to the prefabricated residential architecture. The author also considers that the majority of recommendations and conclusions can be applied to retrofitting prefabricated housing throughout the country.

Graph Model reports for the existing and new buildings may become part of the project documentation for industrialized housing systems. This research project proves that prefabricated systems were well-suited for post-war housing regeneration in Beograd, especially for the building envelope. Their evolution has been positive but irregular. The technology of prefabricated construction was one of the country's most successful product. The author recommends a revision to be undertaken on the currently available systems in order to maximize their outcome (especially IMS building technology). This upgrade should consider the previous experiences and adapt the IMS system according to the future needs based on the approach for more transformation capacity of industrialized housing.

Finally this work provides a systematic approach to proper selection and identification of the best refurbishment scenarios for the existing housing. The current crisis in construction could be an ideal moment to reflect on the need to design and build transformable building structures for multi-unit housing employing innovative construction technologies.

* * *

Acknowledgment

My honest and special thanks to Professor Josep I. de Llorens Duran for his continuous support and guiding. It has been a great privilege to share ideas and to have his guidance and mentorship during these years. The research is based on interviews with planners, academics and architects. This work was made possible as a result of the generous help provided by a number of people. My special thanks to all professionals that support the research project, listed as follows (in alphabetical order):

Aleksandra Krstic-Furundzic, Dr Prof. at Faculty of Architecture - University of Belgrade

Damir Cesko and Pier, Architect in the ADC Biro,

Goran Petrovic, member of the IMS Institute

Ivan Kucina, Professor at Faculty of Architecture, University of Belgrade

Jelica Jovanovic PhD Researcher

Mirjana Laban, Dr Prof. at Faculty of Architecture, University of Novi sad

Stephen Kendall, Professor of Architecture at Ball State University

I would also like to thank Slobodan Mandic for affording me access to a number of useful volumes and original plans in the documents of the Historical archive of Belgrade. Finally, I would like to thank Bojan Milosavljevic and Mark Llopart for reading through a draft and correcting a number of mistakes. Any remaining errors and signs of omission and commission are of course entirely my own.

Refurbishment scenarios for post-war industrialized housing in Beograd

Content

1	<i>Introduction</i>	1
2	<i>Post-war massive housing in Beograd</i>	9
2.1	Building activity in Yugoslavia after the war	9
2.1.1	Period of the first five-year plan of industrialization (1947 - 1952).....	10
2.1.2	Modernization = Prefabrication / (1953-1955).....	13
2.1.3	Industrialization of housing (1955-1985) -"sculptural" buildings	15
2.2	Influential factors on the industrialized housing in Beograd from 1955 to 1985	16
2.2.1	Social and cultural factors.....	16
2.2.2	Technological factors	16
2.2.3	Living standards and building legislation laws	19
3	<i>Principles of housing Industrialization</i>	22
3.1	Choice criteria for structural system, materials, components and joints technology	22
3.2	Construction building technologies	23
3.2.1	Large panel systems.....	26
3.2.2	Skeleton system: IMS Building Technology	29
3.2.3	Best practices of Industrialized Residential Architecture	34
3.3	Building 'in the system'	39
3.4	Industrialization of housing: Building "with systems"	40
3.4.1	Industrial method of systems building	41
3.4.2	Mixed building technology	42
3.4.3	'Open' prefabrication.....	43
4	<i>Industrialized housing adaptability process</i>	45
4.1	Influential factors and parameters for housing adaptability	45
4.1.1	Housing as the 'process' – Variables versus Constants.....	45
4.1.2	Contemporary Housing Requirements – IFT housing	47

4.2	Spatial and technical flexibility and adaptability	49
4.2.1	Spatial and structural flexibility of industrialized housing in Beograd.....	53
4.2.2	Indicators for structural flexibility	54
4.2.3	Adaptability.....	55
4.3	Industrialized housing transformations	56
4.3.1	Different levels of transformations.....	56
4.3.2	Transformations of dwelling layout.....	57
4.4	Open Building approach for industrialized housing	59
5	<i>Methodology for analysis of post-war housing in Beograd.....</i>	62
5.1	Massive housing industrialized systems model	62
5.1.1	Main principle of building structure configuration.....	62
5.2	Graph Model - (GM)	66
5.2.1	Definition of the Graph Model.....	66
5.2.2	Transformation capacity of the industrialized housing according to the graph model.....	69
5.2.3	Elaboration of the proposed method	70
5.3	Definition of the Building Model.....	71
5.3.1	Building Model parts.....	72
5.3.2	IMS Building Model.....	77
5.3.3	Building Model: Case-study analysis.....	82
6	<i>Morphological characteristics of industrialized housing model</i>	100
6.1	Functional aspects	100
6.1.1	Relations between spatial and technical systems	100
6.1.2	Construction module	100
6.1.3	Housing typologies.....	101
6.1.4	Dwellings' typologies	104
6.2	Structural aspects.....	107
6.2.1	Building Model (BM) design.....	107
6.2.2	Structural adaptability	108
6.2.3	Transformation capacity of industrialized housing.....	109
6.3	Environmental aspects	109
7	<i>Functional, Structural, Energy-efficiency analysis of post-war housing in Beograd</i>	111
7.1	Introduction	111
7.2	Great value vs. poor condition.....	112

7.2.1	Building envelope transformations	113
7.3	Current status of industrialized housing	114
7.3.1	Load-bearing structure	114
7.3.2	Building envelope performance.....	116
7.3.3	Installation system for heating	119
7.3.4	Environmental aspects of the Building Model.....	120
7.3.5	Envelope system and dwelling comfort.....	124
8	<i>Integrated refurbishment strategies for industrialized housing</i>	<i>129</i>
8.1	Massive Housing retrofit technologies.....	129
8.1.1	Energy efficiency renovations.....	129
8.1.2	Integrated Refurbishment Scenario.....	131
8.1.3	Current policy for industrialized housing refurbishment in Beograd	139
8.2	Refurbishment scenarios for industrialized housing in Beograd	140
8.2.1	Refurbishment scenario: building envelope improvement	141
8.2.2	Refurbishment scenario for industrialized housing model.....	146
8.3	Improvement of the dwellings' comfort	149
8.3.1	Passive Retrofitting.....	152
8.3.2	Renewable Retrofitting.....	154
8.3.3	Active retrofitting.....	156
8.3.4	Dry construction	157
9	<i>Conclusions</i>	<i>159</i>
9.1	Future research	170
10	<i>Bibliography.....</i>	<i>175</i>
11	<i>List of Figures</i>	<i>180</i>
12	<i>List of Tables</i>	<i>188</i>
13	<i>Appendix - Open Residential Building - best practices</i>	<i>188</i>
14	<i>Appendix - NEXT 21 Open Building experimental project.....</i>	<i>188</i>
15	<i>Appendix - Block No.2: Tower and Condominium building.....</i>	<i>188</i>
16	<i>Appendix - Block No.21 : Meander building.....</i>	<i>188</i>
17	<i>Appendix - Block No.21 : Building B9.....</i>	<i>188</i>
18	<i>Appendix - Block No.22: Tower Building</i>	<i>188</i>

19	Appendix - Block No.45 : Semi-atrium building.....	189
20	Appendix - Block No.63 : Building No.06 B2.....	189
21	Appendix - Block No.64 : Building No.04 B1.....	189
22	Appendix - Energy needs for heating: Parapet façade	189
23	Appendix - Energy need for heating (200m² module): Consumption and Production balance	189
24	Appendix - Photovoltaic Geographical Information System (PVGIS) simulation of the performance of PV system.....	189
25	Appendix - Refurbishment scenarios for post-war housing in Europe: State-of-the-art..	189

Refurbishment scenarios for post-war industrialized housing in Beograd

1 Introduction

Beograd represents the city of post-war social housing where about 250,000 inhabitants live on more than 4000 hectares. Large prefabricated housing estates built using industrial construction methods are to be found in big scale in the settlement known as Novi Beograd. A “block” (the word has become part of the Novi Beograd standard vocabulary) was applied as the basic urban unit and the basic form of urban organization, providing for 6,000 –10,000 inhabitants in an area of 600 by 400 meters. Building of standard housing buildings under laws of rigid technologic functionalism, where form is conditioned by the production process, was considered as exceeding for the rebuilding of Yugoslavia after the war. The biggest building site of the post-war period was an experimental field of new typological and morphological models as well as of experimental construction technologies. In line with egalitarian ideology, it maintained the principle of classification of housing in relation to the number of rooms (according to a pre-determined number of family members, where a bed is also allocated in the living room). Habits and preferences of the potential user groups, on the other hand, were not considered (Giofrè & Miletić, 2012). Mate Bajlon, in an attempt to satisfy the needs of users, introduced the concept of the value of use of the accommodation, releasing it from the standard of the number of rooms and making it responsive to the dynamic needs of a household. The concepts of «livable connection» and «circular connection» innovated the organization of the dwelling by helping to enhance it and make it more responsive to the needs of users (Bajlon, 1979).

The evaluation methodologies of Industrialized Residential Architecture (IRA) of the late 20th century in today's theory and practice were insufficiently refined. As a consequence of this, the values and constrains are not sufficiently understood and established. No large housing estates are being built today using industrialized methods, but maintenance and improvements of these residential urban blocks represent an important task for the sustainable urban future of our cities. Definition of the evaluation criteria and extraction of the important values and constrains of prefabricated construction systems of IRA in Beograd will lead this research toward new operating refurbishment scenarios of the post-war massive housing.

New trends and contemporary needs in housing are causing building design and construction to be oriented to the needs of the user and the environment. EU institutions are supporting such researches in order to find the best solution regarding both similarities and differences with European countries.

To this date, there have been very few topical researches on prefabricated and semi prefabricated residential buildings. In the period between 1965 and 1985 in Beograd (district Novi Beograd), the

technology of prefabrication was implemented in all major residential projects of what was called ‘guided housing construction’² which resulted in more than 20 mixed construction systems. The building structure was based on the integration of different industrialized and prefabricated systems and components, sometimes combined with the conventional building process. The façade was designed as panel-enclosing of a building and was supported by a load-bearing structure that worked as an independent level with no further loads transmission. Also, interior partitions in the skeleton systems were free from building loads and could be placed anywhere in the building layout.

Land area (ha)	4,096 ha
Population	217773
Residential units	90 324
Residential buildings	3265
Total dwelling area	5000 000 m ²
Average number of units per building	24
Average dwelling surface	67 m ²

Figure 1: Residential profile of Novi Beograd (2010 - 2013)(Todorović, Ilinčić, Martinovic, & Ećim, 2013)

The aim of the research is to improve the industrial building models and prefabricated construction systems of exiting post-war massive housing for adaptation. These ‘non-traditional buildings’ were constructed from large scale prefabricated systems (panel or skeleton systems). According to the data collected by the Serbia Statistical Office (Dimitrijevic & Gavrilovic, 2000), about 55 % of the total of 583.908 existing housing units in Beograd was built in the post-war period. The Novi Beograd residential building area is covering 4.096 ha. The high rise residential buildings within consists of approx. 80.000 dwellings and the total dwellings area encompasses 5.000.000 sq. meters (Figure 1). Average dwelling area is 67 sq. meters (Todorović et al., 2013).

The changes and the needs of the different contemporary lifestyles require structures and spaces that can be adapted. The aim of the analysis is to determine the features of the existing physical structure and to evaluate the housing transformation capacity. The special focus is on the building structure, functional organization of dwelling units and environmental performance of a building envelope.

We propose to address sustainable retrofitting of post-war housing in Beograd according to: i) the evaluation of values and constrains of applied industrialized and pre-fabricated systems; ii) analysis of flexibility and transformation capacity of massive structure for spatial and structural transformations minimizing demolitions and waste production.

² Prefabricated Construction in Former Yugoslavia. Visual and Aesthetic Features and Technology of Prefabrication Jelica Jovanović, Jelena Grbić, Dragana Petrović, 2010, Stephanie Herold, Biljana Stefanovska (Hrsg.) 45Post-War Modern Architecture in Europe, Berlin 2012 ISBN 978-3-7983-2435-0 ISSN 1864-8037

Problems concerning the structure in buildings are caused by building methods and almost always involve interdependence of the components and systems. The key obstacles for successful transformation of post-war housing in a building structure are: i) inflexible systems based on complex relations between their parts; ii) inflexible and old installations strongly dependent on load-bearing walls; iii) lack of accessibility to the components that have shorter life and should change with more frequency; iv) fixed integrations between load-bearing and non-load-bearing parts; v) physical and functional dependences in the building structure and labyrinth of interfaces that create complexity for systems to transform.

A major shift towards green housing involves transition from massive building towards adaptability of independent systems and components. Such a concept allows for future upgrading of an entire building and the adaptation of dwelling units. It allows for services to be independent of the structure and provide accessibility and alteration. The main question is how building parts are put together. We have to consider the type of connections between the building elements and what type of components and materials are in the connections.

Furthermore, another question would be what kind of industrial system was applied to apartment buildings. Two industrialized construction systems for IRA were dominant in the period concerned: the pre-stressed skeleton frame and the large panel system, of which the IMS skeleton system and the Rad-Balency huge panel system were the most predominant, respectively. We believe that the establishment of the technical condition of the housing models built in these systems was certainly a starting point for the discussion of the current state of industrialized buildings.

As for our choice of concrete structures, we limited ourselves to the construction period of 1955 -1985, this is an age of buildings of more than 30 years and a time span which exceeds the warranty of 20 years for the construction.

➤ **Principal objective**

The sustainability aspect of industrialized massive blocks of flats is analyzed through the possibility of the industrialized Building Model to be transformed (not demolished) on different levels of its composition/configuration. For the evaluation of the transformation capacity of industrialized housing, the massive structure composition will be analyzed as a configuration model composed of prefabricated systems, subsystems, components and their connections. Flexible use and transformation capacity of BM may be the solution to convert massive housing into more adaptable housing. The research project questions flexibility-in-use provided by overcapacity in the structure. Current adaptation actions in massive housing result in excessive use of resources (by demolitions) while the extra capacity of building model may remain unused during the lifespan of the building. The main focus is on favorable results accomplished by standardized construction elements and simple connections for the building of 'non-standardized' spatial solutions (Figure 2).

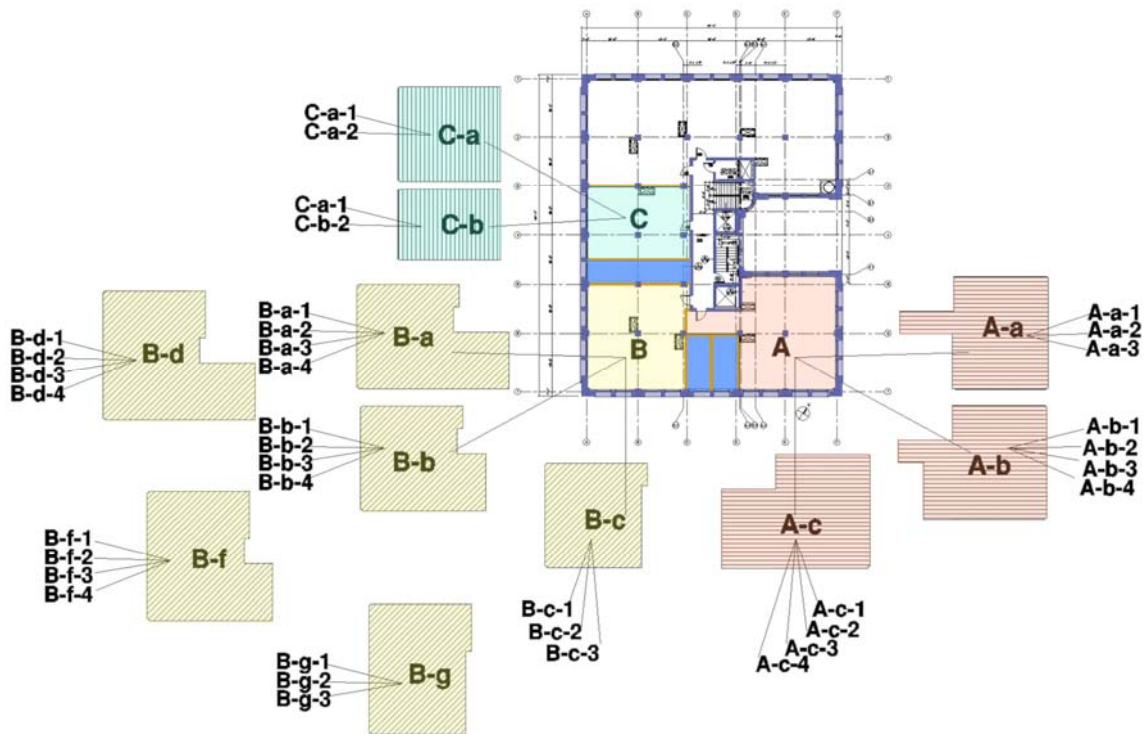

Figure 2: Capacity to replace functionalism by standardized construction elements: Variety of spatial solutions(Stephen Kendall, 2014)

The initial task was to collect and study the available sources and relevant material for the objective review of case-study projects. Case-study projects are documented in the same description and graphic documentation, to be mutually comparable and are evaluable in the appendixes:

Appendix - Block No.2: Tower and Condominium building

Appendix - Block No.21 : Meander building

Appendix - Block No.21 : Building B9

Appendix - Block No.22: Tower Building

Appendix - Block No.45 : Semi-atrium building

Appendix - Block No.63 : Building No.06 B2

Appendix - Block No.64 : Building No.04 B1.

We must consider how we can access and replace the parts of the existing building systems, and accordingly, how we can design and integrate a new components and subsystems for refurbishment of the post-war industrialized housing.

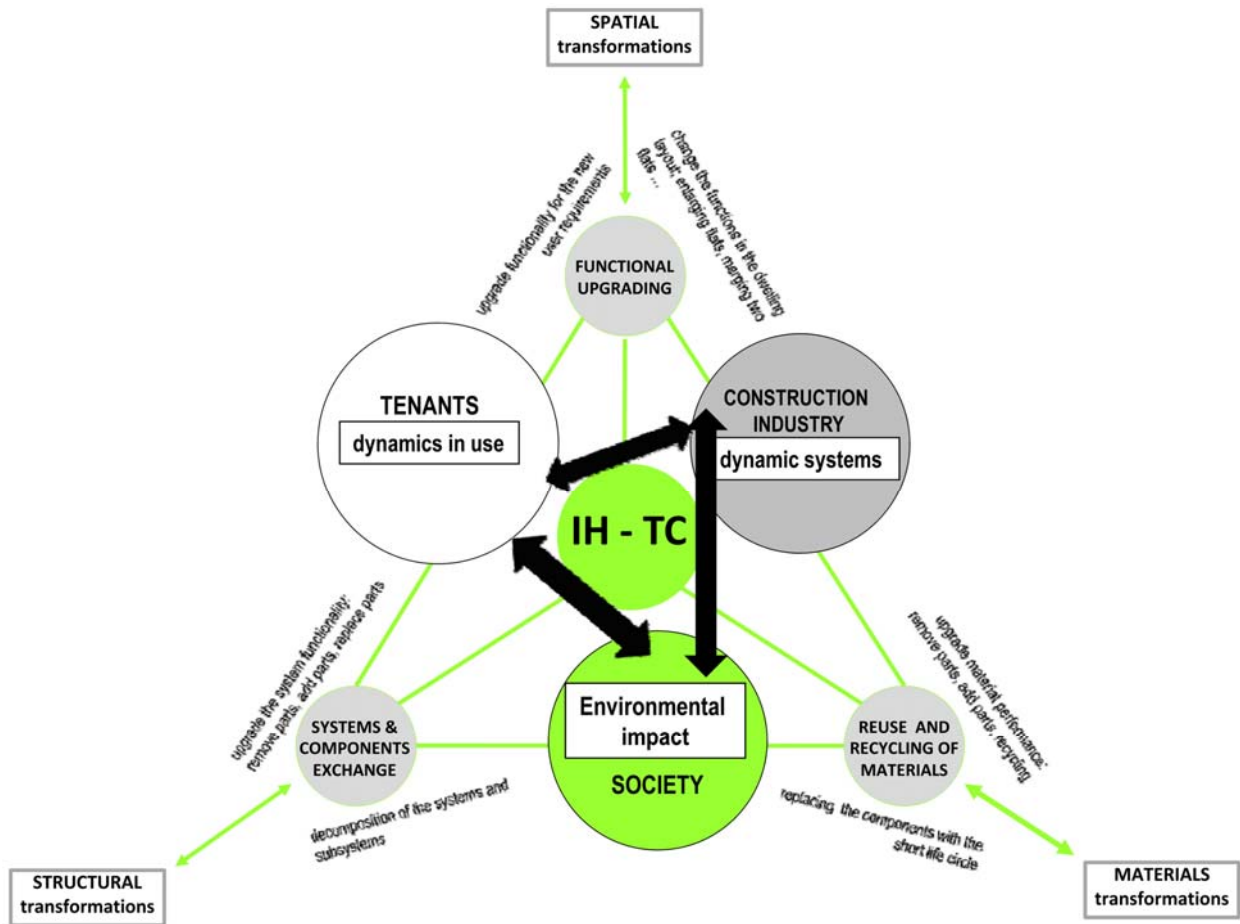

Figure 3: Industrialized Housing Transformation Capacity - IH-TC: Main objectives

There are three main criteria to be taken into consideration during the analysis of the morphology of the structural configuration: functional, technological and environmental criteria (Figure 3). The functional aspect refers to the functional organization of the dwellings and how they are related to the functionality of different building parts. The aim of the functional analysis is to determine the characteristics of the existing dwellings and to make the evaluation of the transformation capacity of these buildings according to the tenants' changing needs. The disassembly of facilities in the building layout is observed within the criteria of the functional flexibility. The technological approach focuses on the overall composition of the assessment and defines the technologies and construction techniques applied. Technology of joints and type of connections are responsible for the transformation capacity of the buildings. The environmental aspect supports the criteria for energy efficiency of built structures and the impact of demolition and waste disposal (Figure 3).

Industrialized housing is based on the integration of systems and components according to the main building functions: load-bearing, enveloping, interior partitioning and servicing. This results in an off-site industrialized construction and on-site prefabrication of systems and components are the load-bearing structure, the envelope, the building services and the partitions. The industrialized housing transformation

capacity will be evaluated according to the dependency conditions between the elements of the load-bearing structure, elements of the outer shell (horizontal and vertical enclosing), interior partitions and the elements of building installations for different facilities.

Integration of industrialized and prefabricated components, subsystems, systems and type of connections (joints) is presented in the Graph Model (GM) and will be analyzed to evaluate dependency conditions and the possibility for transformations. **The GM describes the composition of a Building Model and the physical characteristics of the main parts: the construction system, the structural model, the components assembly, the materials and joints technology.**

As these buildings represent a significant percentage of the entire building stock, they require a fast and detailed study process, in which we offer and conclude the way refurbishment can be made. Also, there is a problem with the ownership, because all of these flats became private property in the 1990's. Across Europe, these retrofit projects are causing great debates between energy analysts whose main concern is lower energy consumption, occupants whose main concern is the quality of life in the buildings and heritage experts (mainly architects and preservationists) preoccupied with the preservation of the aesthetics and authenticity of the building elements and building itself. To make decisions regarding the way industrialized massive housing can be changed or adapted, we need to analyze the Building Model and the possibility to improve the functionality of the dwellings, energy efficiency and architectural quality of the buildings avoiding demolitions and waste production. Therefore the stress in the future development of the refurbishment scenarios should lay on the production of independent systems that take into account the different life cycle and the different functional expectations as well as the different assembly procedures. A systematization of this kind would provide the precondition for the adaptability of spatial and technical systems of a building (Brouwer & Durmisevic, 2000).

HYPOTESIS

- The industrialized technology and prefabricated construction techniques for post-war multi-unit housing in Belgrade would prove to be the only ones capable of producing these buildings within the time frame and budgetary constraints.
- Industrial models of post-war housing do have enough flexibility and can make transformations on functional, structural and energy efficiency level for total building upgrading.
- Industrialized system configurations based on integration of prefabricated systems and components for main building parts (load-bearing, enclosing, partitioning and building facilities) are flexible configurations. This means that they can be upgraded on different functional and technical levels (façade and load-bearing structure are independent assemblies).
- Feasibility to create the concepts / strategies / models and scenarios for the rehabilitation of massive housing on the structural, functional and environmental level. The optimization approach to the refurbishment of massive structures will lead to the integration of energy efficient systems.

➤ **Special objectives of the post-war housing refurbishment**

The building layout will be upgraded in such a way to facilitate the application of regulated and standardized central mechanical systems, the regulation of interior elements and the stimulation of prefabrication in housing refurbishment for a variety of dwelling units. The special objectives are principal requirements for resolving problems on functional, structural and energy efficiency levels. Main problems come from poor technical and maintenance conditions of the building envelope (façade and roofs) and the difficulty of the transformation of the dwelling space. Dwelling units of about 48 m² need more flexible adaptation and functional changes. According to the flexibility of the building model (load-bearing level and envelope level) special objectives for the building retrofitting are defined:

- Create a number of different types of dwellings' within the existing building;
- Enlarging of dwelling units;
- Change position of interior partitions;
- Rehabilitation of the building envelope: thermal bridges, high U-values of windows, poor thermal isolation;
- Transformations of loggia and enlarging the loggia space;
- Watertight construction of the flat roof.

Data collection, which will serve as the basis for analyzing and making conclusions, is collected by observing, and/or recording the transformations and adaptations of the buildings during the time, building maintenance, recording defects of prefabricated systems and elements on the façades and building structure as well as data collected in the Historical Archive of Beograd.

The primary sources for the study of residential architecture of the period are the preserved documents in Archives of Beograd and the Serbian Academy of Sciences and Arts in Beograd - the Museum of Science and Technology (Department of the Museum of Architecture in Beograd), the Beograd City Museum, and the Historical Archives of Beograd; the documentation of the Institute for Protection of Monuments of Beograd, in the archives of IMS INPROS, the JUGINUS, the IAUS, etc. The archives of the above institutes and other institutions in the field of construction. The materials include a variety of regulations, laws, personnel files of architects and collection plans.

As the primary literature, which deals with the industrialized prefabricated building in this period are:

- *Rational residential construction*, special issue of The Construction of Beograd, in 1963. and in 1966.
- *Advising on the industrialization of housing construction*, Proceedings of Beograd 19 - 21 October in 1960., The Federal Chamber of Construction, Beograd, in 1960.
- Canak M.: *Determining the value in the use of structural systems*, Institute for Materials Testing SRS OOUR Center for Housing, Beograd, in 1983.

- Canak M., And bulbs, Z.: Comparative analysis of the functional capabilities of the system and the skeletal system with transverse bearing walls, the Center for Housing, Beograd, in 1978.
- Scientific Journal *Izgradnja*, No. 4, Beogradski Graficki zavod, Beograd, Serbia, 1970.
- Andeweg, M.T., Brunoro, S., Verhoef, L.G.W, *COST C16: Improving the Quality of Existing Urban Building Envelopes I - State of the Art*, IOS PRESS under the imprint Delft University Press, <http://www.iospress.nl/book/cost-c16-improving-the-quality-of-existing-urban-building-envelopes-i/>, 2007.
- Melgaard, E., Hadjimichael, G., Almeida, M., Verhoef, L.G.W.COST C16 Improving the Quality of Existing Urban Building Envelopes II - Needs, IOS PRESS under the imprint Delft University Press, <http://www.iospress.nl/book/cost-c16-improving-the-quality-of-existing-urban-building-envelopes-i/>, 2007.
- Di Giulio, R., Bozinovski, Z., Verhoef, L.G.W., COST C16 Improving the Quality of Existing Urban Building Envelopes III - Structures, IOS PRESS under the imprint Delft University Press, <http://www.iospress.nl/book/cost-c16-improving-the-quality-of-existing-urban-building-envelopes-i/>, 2007.

2 Post-war massive housing in Beograd

2.1 Building activity in Yugoslavia after the war

Before World War II, the architectural planning of Beograd apartments was influenced by public housing in Vienna and Berlin – producing salon-type apartments with a central dining space from which doors opened to the other rooms (Topalović & Kucina, 2010). This sort of spatial organization did not really suit the new way of life and construction in dense city blocks. After the war, architects abandoned the organizational principles of the "central dining space" with the explanation that there were no conditions for such construction in the situation of an urgent need for housing. The first post-war housing buildings were designed for the working class and had been built in the conventional way by reinforced concrete or masonry brick-work as massive structures of the so called 'reinforced masonry' (Jovanović, Grbić, & Petrović, 2011).

Housing architecture in Beograd was financed by both federal institutions and those of the individual republics, as well as the Yugoslav People's Army (JNA). During the following few decades, housing policy in Beograd was strategically oriented towards urbanizing new areas, mostly following the General Master Plan from 1950. According to that master plan, the area of Novi Beograd was to become the most extensive project of building up a new residential district. The housing standards of the Army were high and had been spread over into the entire social sector and become the base for housing development. The Yugoslav People's Army (JNA) was the best organized client and investor, and in 1955 it published a set of 'Instructions for the Construction of Residential Buildings for the Needs of JNA' (Figure 4).



Figure 4: Novi Beograd built according to 'Instructions for the Construction of Residential Buildings for the Needs of Yugoslav National Army (JNA)'

Housing rebuilding period of the first five -years are characterized with the conventional building process and massive industrialization of concrete structure realized in the tunnel formwork. After the 1950' an industrialization of building parts established a new way of building by systems and systems assemblies for floors, walls, façade, installations, roofs, etc. In this research we will analyzed the transformation capacity of the industrialized housing and its special form of prefabrication and the scenarios for the future refurbishment.

2.1.1 Period of the first five-year plan of industrialization (1947 - 1952)

During the first decade after the war, estimated number of apartments that were needed in Yugoslavia were based on the standards issued by the Federal Ministry of Construction. The design of apartments did not really take the tenants' needs and the realities of everyday life into account. Commenting on the military housing, built according to these standards, Mate Bajlon also described the phenomenon of substandard housing: living rooms within the limits of a functional and biological minimum – 14 m² in size.³

In the beginning of the period, with underdeveloped building industry, the conventional building process was the main construction method applied for housing. It was based on a huge cross-wall bearing structures of casted concrete, either skeleton frame or with supporting walls, in combination with brick layering – it was called 'reinforced masonry' (Jovanović et al., 2011).

The difference between the technical lifespan and the functional lifespan of massive housing is too large. On the one hand, the technical lifespan of a building amounts up to 50-70 years (Gijsberg, Lichtenberg, & Erkelens, 2005); on the other, it may no longer fulfill the function after 20-30 years. In 1944, Beograd's population numbered 280 thousand, some 50 thousand less than in 1941, according to the estimates. The city had entered the war with a serious lack of public resources, and during the war it lost around 30% of its apartments (Giofrè & Miletić, 2012). It was now growing very rapidly, so that, by 1960 the number of its residents had already doubled, with a growth rate that was twice as fast as in the period before the war. As the population grew, Beograd People's Committee implemented a General Master Plan of Beograd which encouraged a more dynamic expansion of the city towards the periphery. The plan stated that the city should be expanded by developing four new, well-planned housing zones. Gradually, the classic systems were replaced by prefabricated and semi-prefabricated, while the production technology was being upgraded into an industrialized construction technology. However, traditional construction methods were still applied; a combination of the conventional construction of reinforced concrete on site and prefabricated façade was very common practice. The developers of the prefabricated systems did not

³ M. Bajlon, V. Hruška, J. Klepac, A. Ranković, A. #evgić, D. Vukčević Sarap, and A. %anko, Stan I i II [Apartment I and II] (Beograd: Committee for Publications on Military Architecture, n.d.).ts' Association, 1997), p. 27

insist on the building in the system, especially if the costs would rise or the deadlines were not being met, which lead to the mixed systems building.

• ***Industrial method of massive structure***

Most of the massive, post-war housing in Europe are demolished or planed for demolition because the building unsuitability for spatial and technical changes. The conventional construction process has created strong burden conditions to the dynamic and changing society of the 21st century. Building structure of permanent and fixed connections and mixed systems where materials and components rely on each other in order to provide the desired functionality are not sustainable if we compare the average lifespan in use with the technical lifespan of the building structure. An adaptability process of strongly dependent parts in the solid model is related too high rehabilitations costs, important demolition process and waste production. The key obstacles to successful transformation and upgrading of 'solid' models are:

- Inflexible load-bearing structure because of the fixed connections between components and materials;
- Inflexible load-bearing structure because of the cross-bearing system (large panel support system receives loads in both directions: longitudinal and lateral);
- Load-bearing interior partitions (inflexible building layout);
- Lack of the load-bearing structure for reconfiguration and modular extensions;
- Fixed integrations between load-bearing and non-load-bearing parts of the structure;
- Inflexible and old installations' systems that cannot be adapted and exchanged;
- Lack of accessibility to the components that have shorter life circle and should change with more frequency;
- Lack of the configuration for new energy-systems integration;
- Physical and functional dependences in the building structure and labyrinth of interfaces that create complexity for buildings to transform.

The strong dependency between building parts and rigid connections are the boundary condition for transformations and adaptability of massive housing in Europe. Building construction technology by fixed connections between components is considered inflexible.

The first housing in Beograd after the war were designed and built as a mixed structure of the conventional construction for cross panel bearing system and prefabricated systems for façade. Inevitable changes in the building layout will affect the integrity of building structure (load-bearing partition walls). Buildings often suffer a transformation due to the degradation of more dependent materials and components according to frequent changes of the user needs and the technical systems upgrading. Conventional building is inflexible in the service phase due to the mixed functions, inflexible and fixed connections and lack of accessibility to the components with the shorter life-cycle. For this reason, the

structural transformation is related to partial or total demolition of building parts, significant loss of energy, materials and waste production. To remove or to relocate the interior walls for the functional changes in the dwelling layout, the conventional systems undergo the process of demolition of the walls. The first step to handle the dependency tension in the construction is through the independence and exchangeability of the fast cycling components.

• *Definition of 'closed' system*

In Beograd post-war reconstruction process 'closed' system may be defined with a complete set of assembly elements needed for construction. Housing buildings were fully accomplished with these elements alone put into a mostly permanent connections. The tunnel formwork was applied for the cross bearing walls of the first concrete structures where the interior partitions and façade belong to bearing system. Different building functions were mixed by fixed connections between elements. Construction of the load-bearing system in the conventional way had been accomplished with industrialized and prefabricated components. According to fixed connections existing buildings do not offer the possibility of adapting the system to a new requirements. Different functions and materials comprising a building are integrated (during construction) in one dependent structure that does not allow alterations and changes. Demolitions of the building parts can be defined as the process whereby the 'closed' building undergo changes, with little or no attempt to recover any of the constituent parts for reuse. Most buildings in post-war Europe are designed for such end-of-life scenario. 'Closed' system configuration and fixed connections are the principal motive for the low level of housing transformation capacity (Schwieger, Zhang, & Wengert, 2010).

• *Definition of 'open' system*

The main feature of an 'open' system is flexibility – the possibility of adapting the production of assembly elements to various architectural solutions. The basic line consists of elements that determine the type of construction, but there is a choice in the use and the possibility of alternating the elements according to the needs of construction as well as mixing of different building technologies for different building parts. With each improvement, the system can grow in the number of elements and offer an increasing number of options in terms of building adaptations. After each phase of use, system configuration should be designed and built to indicate a building suitability for transformation according to new changing requirements (Durmisevic & Yeang, 2009). This structure we call '*open*' system configuration model. In the '*open*' system configurations, components and subsystems can be exchanged at all levels of technical integration to increase total building performance. The open system can exchange parts, components and even sub-systems outside its original production context. Interchangeable parts, components and subsystems are the constituents of an '*open*' system. They offer more options to the user and a larger market to any manufacturer in terms of quality (performance criteria), dimensions (modular coordination) and interfaces (compatibility).

2.1.2 Modernization = Prefabrication / (1953-1955)

A resolution of the Federal Assembly in 1965 about the system of the housing economy stated that housing development was lagging behind the current needs and that an increase in volume and rationalization in that sector could be achieved only by modernizing the technology and applying industrial construction methods, after which segments of the building industry became specialized in the construction of apartment blocks.

According to the demographic changes and the drastic shortage of urban housing facilities, construction companies adopted projects of mass housing construction, with the technology that was available to them at the time, as well as that which they were developing through the import of technologies. Parallel to these construction projects, the first research projects had been announced in the domain of building technologies and developed the first locally manufactured products. Using its previous knowledge, conventional methods of construction, and available tools and materials, and then combining them with imported or locally developed building technologies, the building industry created a whole range of specific mixed construction systems that would become the main feature of its housing architecture through integration of building technologies, in which the technology of prefabrication found its broadest application. As a symbol of the country's reconstruction and development, the Novi Beograd was the largest building site in former Yugoslavia. The housing construction of the Novi Beograd was strongly supported by the research process and scientific basement which supported and influenced for decades the housing architecture (Kulic & Mrduljas, 2012).

Two generations of post-war housing can be observed:

- ***The first generation of skeleton framed and large-panel buildings (1955-1965)***

Small flats with the average built-up area for four persons were 48 m² (***Error! Reference source not found.***), with one or two bedrooms and there was also one bed in the living room. Simple layout of flats was small kitchen, bathroom, dining area, and no storage area. Simple façades with no terraces, no loggias, and no shops on the ground floor, flat roof, and small entrances were designed by rows of windows and parapets. In many cases the same elevation was for the north and south façade. Pure technical background - very bad insulation (U value for external walls: U=1,50- 2,30 W/m²K), no sound insulation, no summer shading for windows, bad heating and sanitary systems.

- ***The second generation of skeleton framed and large-panel buildings (1965-1985)***

Slightly bigger flats and new dwelling typologies characterize the residential building from this period. The average built up area of the flats for four persons were 54-63-75-100 m², with two or three small-size bedrooms and living-room. Building layout of flats has been developed in more complex distribution of functions and space use. All apartments have a living room, bigger kitchen and with new functions: dining and storage rooms.

Slightly improved façades with loggias or balconies, small amounts of buildings pitched roof or built-in attic. The improved town-planning created small squares and streets, little connection with the other part of the city, bad public transport, and half of the buildings were high-rise buildings (mainly with 11 stories). Improved technical background of vertical enclosing became with little heat insulation (U value for external walls: $U = 0,59 - 1,1 \text{ W/m}^2\text{K}$), with no sound insulation, no summer shading, bad heating and sanitary systems.

• ***From the solid model to system configuration***

According to Brand systematization of building into a six functional layers (Figure 5) for the industrialized post-war housing in Beograd has been applied a decomposition method of total building structure into four main technical levels (load-bearing system, envelope, services and partitions), will be considered to explore the level of dependency between structural elements for further evaluation of the housing transformation capacity.

Industrialized, Flexible and Transformable (IFT) principles had been introduced for the analysis of the system configuration model and defines main research hypothesis: Is the massive structure of post-war social housing in Beograd an Industrialized, Flexible and Transformable (IFT) model? Industrialized systems and structural elements are made under the factory conditions; Flexible- system configuration facilitate adaptability of spatial and technical systems and changes at various levels of building integration; A transformable system meets the requirements for model transformations by simple joints. Finally, the improvement of building capacity to adapt to spatial, technical and environmental changing requirements and consequently extend the service life of the building and its systems will be considered as a key issue of sustainable development in the massive housing refurbishment. Contribution of the future work is two-fold: First is identifying of the main technical and functional systems and components and its systematization based on the independent levels and systems method; second is the analysis of the main characteristics of the post-war system configurations.

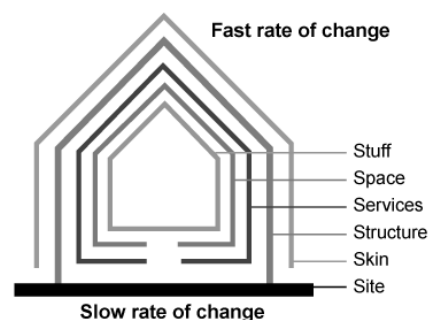

Figure 5: Building layers according to Brand – “Sharing layers of change” (source: Stewart Brand, *How Buildings learn*, pp12-13, 1995)(Brand, 1995)

The reconstruction of the network between different functions and technical levels is based on independence and exchangeability aspects for the systems and components that have a different life span

and functional expectances. Network aspects determine the transformation capacity of subsystems and components for flexible and demountable system configuration.

2.1.3 Industrialization of housing (1955-1985) -"sculptural" buildings

Housing estates, big-scale buildings, units of housing estates (private or state owned), 5 to 20 story buildings, built with reinforced concrete panels (factory prefabricated or fabricated on site by tunnel formwork) and skeleton frame construction systems, are the subject in this research. Since the 60s all housing buildings had been built according to "new" rules for construction by parallel actions for faster building on site. Different building technologies were evaluable as well as a range of industrialized components for systems integration.

In Europe Open Building method was developed by N.J. Habraken in 1960, approaching building design and construction process by principal division of housing into two independent parts: "support" - building structure and "infill" - detachable units. Open Building implies a two-fisted strategy. In a social perspective it seeks to respond to user's preferences by offering flexibility needed for adaptation of individual units over time. In a technical perspective it seeks ways of building where sub-systems can be installed or changed or removed with a minimum of interface problems (Habraken, 2003). The design and building of more permanent building parts (load-bearing structure) offers flexibility for variety of dwelling arrangement and make possible future transformation of housing units according to the independency of structural components and systems (*Appendix - Open Residential Building - best practices*).

Building technology of prefabricated construction was one of the Yugoslav country's most successful products. The country was exporting and importing new prefabricated systems, which resulted with more than 20 integrated prefabricated systems being in use by professionals for building housing.

For several decades the application of prefab technology had been perceived as the only effective solution for the housing crisis. This opportunity was seized as convenient for a well organized industry to evolve and grow, designing the array of prefab-products: from structural and façade elements to fully equipped buildings. The architectural design and production went completely the other way from what initially started off as plane and completely simplified two-systems-technology based upon two prototypes huge panel system, and skeleton system.

In an effort of creating the authentic architectural expression, built to represent the Yugoslav production, but also to be competitive and compliant in global market, architectural design was presented as a major asset. It was modern, functional, flexible, exhibiting the undeniable qualities of diverse architectural scene and offering everything: from 'contemporary' to 'traditional' (Topalović, 2011). A variety of structural models had been design and built by integration of prefabricated systems and components to obtain flexibility in the housing layout. The housing construction went under the approach of „open“

prefabrication technology, characterized with flexibility and adaptability suitable to architectural solution. The basic offer consists of elements for supporting structure, but provide an assortment in use.

2.2 Influential factors on the industrialized housing in Beograd from 1955 to 1985

2.2.1 Social and cultural factors

In Yugoslavia the prefabricated construction was determined by the policy of launching architectural competitions for all housing projects that were financed by the state and its institutions. The socialist system of Yugoslavia created precise mechanisms for financing collective residential buildings. Investors of the most ambitious and best-equipped residential complexes were closely connected to the government. The army, police, and state administration, the most efficiently organized structures, present in all parts of the country through their networks, managed to identify the emerging forms of the housing crisis and estimate its proportions better as well as regeneration projects schedules. The first housing projects were structures formulated most precisely for the officer, the civil servant, the bureaucrat, and the worker. The employees with privileges had special rights and standards according to which their apartments were designed, constructed, and equipped.

The fact that the new construction methods could be applied only together with the overall industrialization of the building process led to the gradual emergence of the infrastructure of residential architecture, with its two main aspects: the building operative control of the multi-action building processes, which included the process of making and implementing plans, as well as financing – implying also the distribution of apartments and eventually the empirically based standardization of construction. The first step was to redevelop the design and construction technologies, to harmonize them with the production of the construction materials and elements to industrialize the process and to divide the building into different construction parts for parallel assembly process (Jovanović et al., 2011).

According to that master plan, the area of Novi Beograd was to become the most extensive project of building up a new residential district in terms of area size – with plans to continue the irrigation of marshlands and construction works initiated immediately after the war (Jovanović et al., 2011). Several sources emphasize the fact that projects of residential architecture, which were financed from the state budget, had to be obtained through public competitions. Competitions were organized by the Architects' Association in charge.

2.2.2 Technological factors

Post-war housing industry is related to the formation of the structural systems based on the division of building process into primary and secondary building elements. In the 60s, the state of former Yugoslavia had the urgent issue to rebuild a devastated housing area. Before 1960, almost the only technology used in

construction was cast in place concrete and brick masonry for the homogeneity of mass housing as a finished and repetitive product (Habraken, Wiewel, & Gibbons, 1976). During the period of fast housing re-building, the building strategy had been set up to ensure the next main issues: lower construction costs, short delivery time, control of building process, narrow and clear specialized job, avoiding mistakes, avoiding complexity. The traditional building process with massive panel and brick formwork couldn't work according to the demand and time conditions because of the complexity of building process, a number of non-qualified workers, complex workout on the site, long time schedules, non-sufficient economical support, to many construction errors dealing with complex relations between different building function and corresponding technical systems.

According to the needs for more flexibility and simplicity of construction process, building process has been segmented according to the main building parts: load-bearing system, building's façade, interior walls and supply systems. That was a transition process from the massive concrete 'cast in' place structure where components rely on each other by mixed functions and fixed connections to integrated systems prefabrication. Division of the building process by independent technologies set up the first system configuration for housing structure: i) load-bearing system (primary construction) and façade system (secondary construction). After the Second World War, the increase in population and hence in the demands for residential space in Beograd, have given rise to an extensive development of prefabricated structural systems as a substitution for the conventional way of building (*Jugomont, IMS Žeželj, Rad-Balency, Ratko Mitrović, Neimar NS 71, Trudbenik*).

All the examples of the application of prefabricated systems represent a modification of the original systems or the mixed systems according to the needs of a particular project. Another fact must certainly be emphasized: prefabricated systems, especially those that were imported, were adjusted to the architectural norms, which in Yugoslavia prescribed 16m² of floor space per person, compared to the 20 m² in Germany (Jovanović et al., 2011). Therefore, the best solutions were obtained by adapting the system to every individual housing project and housing demand.

In the beginning, prefabricated elements were developed for low-rise structures of up to five stories. The development of the technology of production and assemblage enabled development of these systems for building structures up to 20 stories. Three different levels of industrialization are applied:

- Structures with huge panel system for floors, roof and walls;
- Structures with massive floors and walls panels and building envelope performed in an industrialized way;
- Structures of skeleton construction system with vertical and horizontal enclosing (most or all) performed in a factory, using industrialized panel components for façade walls and parapets.

Most common structural models for post-war housing are:

- Prefabricated Reinforced Concrete (RC) panel model – the type with slabs spanning between load-bearing transverse walls and with non-load bearing façades;

- Industrialized Precast Skeleton (IMS) construction system - skeleton frame of slabs and columns with non-load bearing façades (Figure 6).

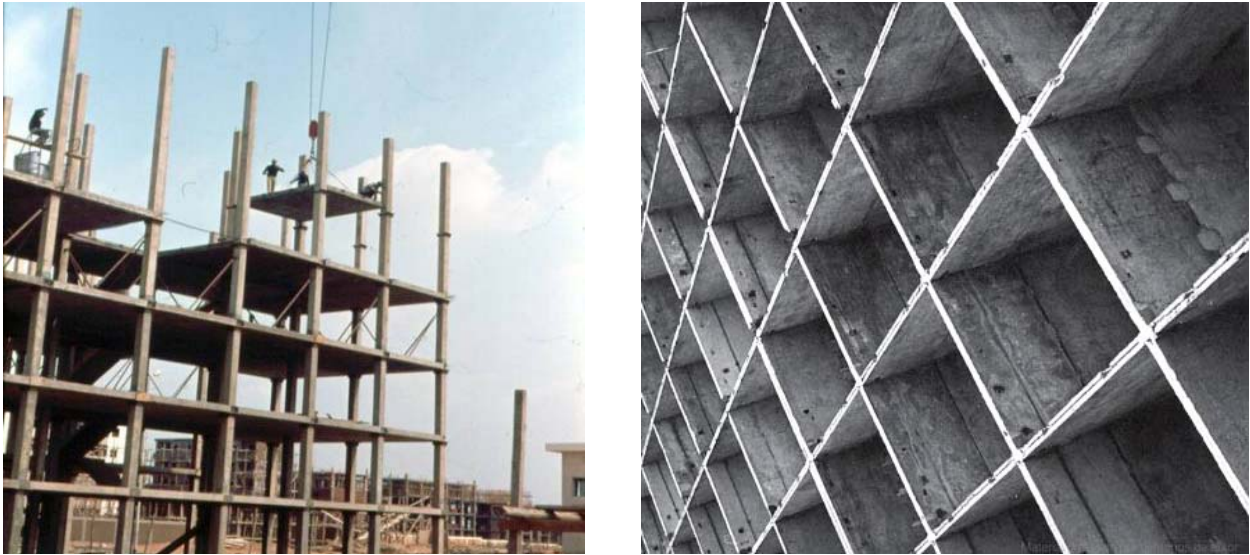

Figure 6: Structural models of post-war industrialized housing: Industrialized Precast Skeleton (IMS) construction system; Prefabricated Reinforced Concrete (RC) panel model

The transformation capacity of these buildings depends on: the production technology, the way of connecting structural elements, the composition of the system assemblies, the reinforcement, the configuration of the contact areas of elements and the system of joints.

- **Prefabrication = Industrialization**

Industrializing housing was the largest step that the building industry took in order to accelerate and control the construction process. As the building operations were segmented, it turned out that the first indispensable step was to keep the building process segmented and to connect these various segments of the process into the assembling procedures – from the production of raw materials to the building site. Modifications of the laws in the domain of industry and construction in 1960 created the preconditions for establishing cooperatives and business associations, which integrated various processes in the building of apartment blocks. In the period between 1960 and 1985, the technology of prefabrication was implemented in all major projects of what was called “guided” housing construction.(Jovanović et al., 2011). A big-scale buildings, units of housing estates (private or state owned), 5 to 20 story buildings, primarily built with reinforced concrete panels or skeleton frame systems with secondary applied systems and components for façade, roof, services, installations are the subject of the research.

In the further development of the technology of prefabrication, the production system was divided into the elements of primary or load-bearing construction and those of the secondary construction or façades, which made things easier for architectural design. The traditional building methods of production and the

assembly of concrete blocks at the building site, were gradually, as industry evolved, supplemented by prefabricated or semi-prefabricated elements – although they were never abandoned. A combination of classical and prefabricated systems was very frequent in both primary and secondary constructions (Figure 7). Design of individual buildings, capacities of the building companies, problems with maintaining deadlines, and high construction costs were the main reasons for this inconsistency of construction "in the system" from the very beginnings of the implementation of the industrial construction technology.

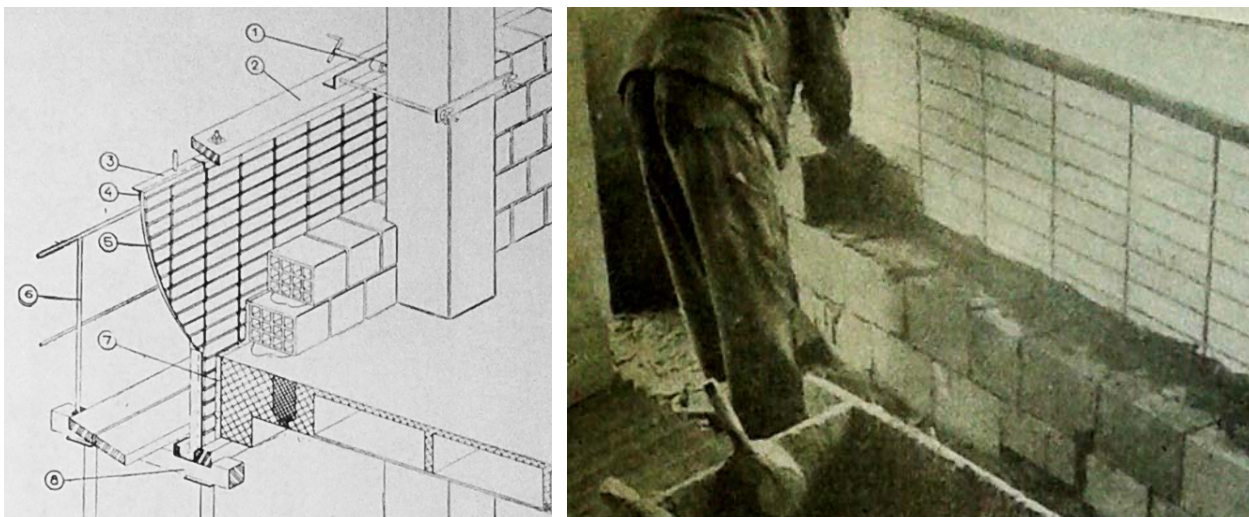

Figure 7: Combination of conventional and prefabricated systems in façade construction (Block No.21-Industrialized concrete parapet (6 cm + ceramic tiles), conventional brick parapet from the inside (19 cm))

2.2.3 Living standards and building legislation laws

The guiding of the building process took place after the housing reform of 1960, which transferred the construction and use of apartments from public domain to the private one (*Act on the Specific Preconditions for the Construction of Residential and Administrative Buildings, and Social Control over this Construction*). As early as October 1960, at the Seminar on the Industrialization of Residential Architecture, the industrialization of processes in the building industry (production of materials, building blocks, etc.) occupied the first place among the priorities in guiding the building industry. The planned number of apartments on the annual or five year level could never have been accomplished with the traditional building technologies. Economy was a valuable factor for the building choice technology and depends on local resources, available materials and labour, inter-relation of material prices and labor, assignment overall and execution period. A relatively high price of labour requires decision about the use of larger machinery level and about the shortage of labour participation. The machinery investment and the optimal section capacity definition per year shorten a construction period.

- **Housing policy (Beograd)**

During the communist political area, three main types of ownership were created. The main part of the new dwellings in Beograd was owned by the state and the army, and rented by families with two or more children, or families who were privileged on the basis of political background (more than 80 % of the flats). Families with no children or families with better income had to buy homes from the National Bank (About 10 % of the flats). After the changes of post-soviet times, the state-owned flats were sold for tenants under the “Right to buy,, - the tenant had the “right” to by their flats at a very cheap price (10% of a market-price). Within 5 years, 98% of homes passed from public into private hands, as shown in the 2002 Census (Giofrè & Miletić, 2012). This resulted in an opposite structure of ownership. Now only 4 % of the flats are rented, the other percent of the flats is owned. The families with low income bought their flats for a cheap price, but they couldn't provide its maintenance. That is the reason of obsolesce of the housing estates. During the last 30-40 years the pipes, wires, windows, carpets, floor covering had no change. Within 5-10 years in spite of the main structure, almost all the building components must be replaced or refurbished. The single parent families or retired couples are not able to accumulate enough money to solve these problems. They are not able because of the very high running cost of the under-insulated buildings. The families must pay a monthly sum for the reparation works (leaking roof, damaged elevators) but it is enough for the works. An average family must pay 50 % of an average salary for the cost of an average (54 sqm) flat (Trbojevic, 1982). The management has no high-standard education and no real help from professionals, partly because they don't have any financial background to pay for professionals, and partly because they have not realized the necessity of that. The Serbian government started to introduce different solutions in order to save energy and cost. The buildings that applied for the financial help from the state have to submit an application to show the estimated work and cost.

Cost of the utilities: a good example of improved accountability and convenience in payment of utility bills is the system for the ‘Integrated housing related payments’, introduced by 'infostan' in Beograd. Apart from THE utilities, the ‘integrated bills’ include all the other housing related payments (maintenance, environmental fees, insurance, etc.), with the exception of the individual electricity consumption. The average amount per customer for October 2012 was about EUR 65 (nearly 25 per cent of an average household income) (Trbojevic, 1982)

• *Management of multi-apartment housing*

Management and maintenance of the housing stock is still one of the priority issues of the housing sector. Management of apartment buildings is regulated by the *Law on Maintenance of Residential Buildings*. Management is treated as a series of decisions and activities securing adequate maintenance, funds and use of common spaces. An apartment building is a legal entity; the decision-making body is the ‘building assembly’ (for buildings with over 10 units) or the ‘building council’ (for smaller buildings). Establishment of the legal entity requires a quorum of 51 per cent of all owners, while decisions on ‘investment maintenance’ require the consent of members owning over 50 per cent of the total building

space. The assembly/council is free to decide on the organization of maintenance (whether to assign it to a professional company or take care of it itself), but should communicate its decision to the local administration within 15 days. In cases of poor performance, a building inspector may ask a maintenance company to carry out necessary repair work at the expense of the homeowners. Thus performance of maintenance is an obligation of owners' associations under the supervision of local administration. The distribution of maintenance costs is proportional to the relevant owner's space in the building. A draft amendment to the maintenance law intends to reintroduce a compulsory monthly fee for emergency repair work.

3 Principles of housing Industrialization

3.1 Choice criteria for structural system, materials, components and joints technology

The industrialization of the housing in Beograd was based on the criteria to design and choose structural systems, systems assemblies, components and joints technology. In order to fully explain the concept of housing industrialization and systems prefabrication, we have selected some of the definitions of these concepts in our and foreign literature. Thus, our literature specifies the following: "Industrialization of construction means a collection of technical, technological and organizational measures and methods applied in order to facilitate and expedite the production and rationalization of consumption of resources required for the production." While one of the most widely used vocabulary of architecture in the world says: "The Industrialized Building is everything: Architectural and constructional techniques are dependent on prefabrication.", where "Prefabrication is manufacturing of parts of a building in a factory before they are brought to the site for incorporation into the finished structure."(Schoenborn, 2012)

The construction system (with industrialized components and subsystems) is a set of basic structural elements and by its multiplication is obtained the structure of the whole building. Many housing systems in Beograd are of mixed type models, and cannot be so easily categorized. Application of a specific construction technology and method of execution is closely related to the degree of implementation of prefabricated building components and systems. Work on a building construction can be primarily divided into two categories: work on the development of the structural system (load-bearing and envelope) as the more permanent building part, and completion including all the other works for partitions, installations, installation of equipment and devices, final assembly sections and equipment. The most important classification of structural systems for this research will be according to the flexibility of the building model. The nature of the technical composition of the building is crucial for the life cycle of functional and technical systems. It is not only the type and durability of material(s) but more importantly the arrangement of components and the relation between them that determines the building life circle.

The main aspect of post-war housing was industrialization and prefabrication of the structural system (load-bearing system and façade) according to a specific design requirements for flexibility and diversity of dwelling units. The same building technologies have been applied to various building models to satisfy different needs for both: the minimal dwelling and the luxurious apartments. We will analyze the Building Model (BM) and its suitability for maintenance and transformation of more independent parts. This analysis will consider composition of all technical levels and underline different types of connection between the components and components assemblies. The building structure and building technology are of great significance for defining the integrated refurbishment scenarios and possibilities of realization.

• **Technology of Industrialized Construction**

Totally prefabricated construction systems had been applied for the second generation of post-war city regeneration, completed with prefabricated elements assembled on site (partitions, parapets, slabs, with pre-installed installation and finishing). To access the process for evaluating the existing massive housing blocks, it is necessary to establish the criteria for building analysis.

A housing industrialization does not necessarily imply a high level of elements prefabrication. Industrialization itself involves only the use of industrial methods and improving the construction technology for more quality, faster execution and lower costs. **Thus, we conclude that the way the prefabricated components and systems are assembled is an essential criteria for future housing refurbishment of industrially derived buildings.**

3.2 Construction building technologies

The building construction technologies applied for the reconstruction of Beograd after the WWII can be classified as the following:

- **Conventional building technology** – masonry and concrete works “in situ”, cross-wall bearing systems and short construction spans.
- **Advanced conventional construction** – use of portable, sliding, space-tunnel formwork for concrete work in-situ, incorporating concrete and brick semi-prefabricates components for mixed structural systems.
- **Industrialized constructing - semi-prefabrication** introduces a serial production principle for standardized building parts – columns and slabs, accompanied by the classic construction of some building elements.
- **Industrial constructing – total prefabrication** followed by serial production of all building elements as standardized.

Conventional construction	Reinforced concrete framed structures: traditional wooden formwork, Brick masonry walls
Advanced traditional constructing	Reinforced concrete structure: large panel system cast-in-situ combined with some prefabricated elements for façade and roofs
Industrialized constructing: semi-prefabricated systems	Structures based on large panel system: tunnel formwork combined with standardized building parts for façade
Industrial constructing: prefabricated systems	Prefabricated prestressed concrete skeleton; IMS building technology, Rad-Balancy system, Trudbenik system, Yugomont systems

Figure 8: Classification of construction building systems applied for post-war housing reconstruction in Beograd

Conventional construction is characterized with the long lasting building process, trade methods are applied with the significant labor capacity for the work realization ,machinery is not in use; all the operations are realized at the site, such as processing of forms, concrete reinforcing, etc. Small concrete and brick elements are used for construction. Finishing and installation works are processed in a trade way, without any significant parallel process. It consisted mostly of classic supporting structures of casted concrete, either skeleton frame or through supporting walls. Gradually, the classic systems were replaced by prefabricated and semi-prefabricated systems through an upgrade of the production technology. Combinations of the classic supporting system and prefabricated façade were very common (Waley, 2011).

Advanced conventional construction shortens the building period using simple equipment and half-prefabricates. Advancement refers to concrete preparation in constant sections and delivered at the site by truck mixers, to already-made reinforced assemblies brought to the site and then incorporated into special forms, as well, aimed at complex use, concrete incorporation plant – form or poker vibrator, small dimensioned elements – lintels, ceiling slab stems, staircases, installation assemblies of water supply and drainage, windows, doors, floor and ceiling covering (Dimitrijevic & Gavrilovic, 2000). Construction in different types of formwork was also widely in use, in combination with prefabricated elements.

Industrialized construction - semi prefabricated systems combines industrial principles – labor division and serial production of elements (the most usual structure prefabrication) – followed by advanced trade constructing ways for the buildings parts, where standardization and prefabrication are not rational or offer rigid and non-functional architectural solutions (different form types for repeated use – portable, sliding or tunnel are applied). Serial production of selected standard elements, organization and parallel activities concerning production and prefabrication process, abbreviates the constructing period, uses material and labor rationally, controls work and element quality but requires significant investment in equipment, transport and erection facilities for larger and heavier elements or adequate forms. Mixed building technologies of conventional construction and prefabricated systems and components were applied.

Industrial construction – total prefabrication absolutely respects the division of the building structure according to four main parts: load-bearing, envelope, partitioning and services. Façade components or partition walls have almost always integrated installations, windows, doors or finishing. Several various materials are used in section, which makes the production technology complex and not flexible at the material level. Two prefabrication lines were applied:

- **Total prefabrication 'in the system'**: all building parts are prefabricated by the same building technology (IMS building structure);

- **Total prefabrication 'mixed systems'**: different building parts belong to different building technologies (IMS load-bearing system, vertical and horizontal enclosing from different fabricants).

We can emphasize that the traditional massive building structure has been replaced with an integrated building system by prefabricated components and systems. The construction companies in Yugoslavia grew fast due to the mass infrastructure renewal projects. By the beginning of the 50's, there was a great demand for the construction work in big housing projects and at the same time the foreign systems and domestic researches in that field had a large influence on the building technology.

Construction type	INDUSTRIALIZED SYSTEM FOR HOUSING BUILDINGS	No. of built apartments																				Total No. of built apartments from the beginning of the system use until the 1982			
		1957	1958	1959	1960	1961	1962	1963	1964	1965	1966	1967	1968	1969	1970	1971	1972	1973	1974	1975	1976		1977	1978	1979
Skeleton system	IMS	4.908										12.222										3.320	20.450		
	RAMIT-Ratko Mitrović											547	4.530										133	5.210	
	DOM												2.289										983	3.272	
Panel system	KOMGRAP-Standard beton 'KSB'						660					1.912										440	3.012		
	TRUDBENIK						1.700					9.863										627	12.190		
	NEIMAR Beograd-NB						820					3.200										480	4.500		
	RAD-BALENCY											1.972					1.780	3.752							
Mixed construction systems with prefabricated façade						1.100					2.173										927	4.200			
TOTAL	9.735										38.161										8.690	56.586			

Figure 9: Number of built apartments in Beograd by industrialized building systems (skeleton and panel system)(Krstic -Furundzic & Kosic, 2013)

Prefabricated systems found their use in almost every housing project in Yugoslavia between 1960 and 1985 (Figure 9). Mixed building technologies were applied for the housing projects at the beginning of the reconstruction period. Classic supporting structure of casted concrete with prefabricated envelope and interior partitions, are very common mixed systems. In order to define the basic features of the housing of the period, the characteristics of the two most common systems of prefabricated building in use will be described, since the architectural design was in great deal influenced by them.

3.2.1 Large panel systems

Many construction companies modified their existing, mostly classic panel systems from the "in situ" reinforced concrete to the assembly type of construction. Most of the prefabricated components were done on the building site. In the later decades, by the beginning of the 80s, part of the production was moved to the factories of concrete elements, but the large part of the production of the façade panels was still done on the building site since they were produced by specific architectural design for each project the technology was imported. They were modified to meet the conditions of construction on site and, in many cases, the conditions of architectural design. Different prefabricated systems have been developed, many of them imported from Europe and adapted for the national standards. Most applied panel systems in Beograd were: Rad-Balency, Montastan, Yugomont YU59, 60, 61; Trudbenik,.

➤ Rad-Balency

The huge panel system Rad-Balency is applied to tower buildings from 6 up to 22 floor. Most of the building in blocks 61-64 are built in cross-wall bearing system. A building model consists of structural walls, floors and non-load-bearing façade. Walls are 15 up to 20 cm thick, prefabricated in the industry and assembled on site. The ceilings are filled concrete slabs made on the building site stretched in one direction. The entire connection between structural components is monolithic (Figure 10). Ranges of these system achieved in practice have shown suitable for residential development because they match the modules used in the design and could be combined. The module of the 60 cm is applied for structural elements. Vertical bearing panels may have different dimensions from 1.00m to 6.00m long with the 2.67m constant height. The upper and bottom bearing panel edge has a special interface geometry for the concrete connection in the systems beam (Figure 10).

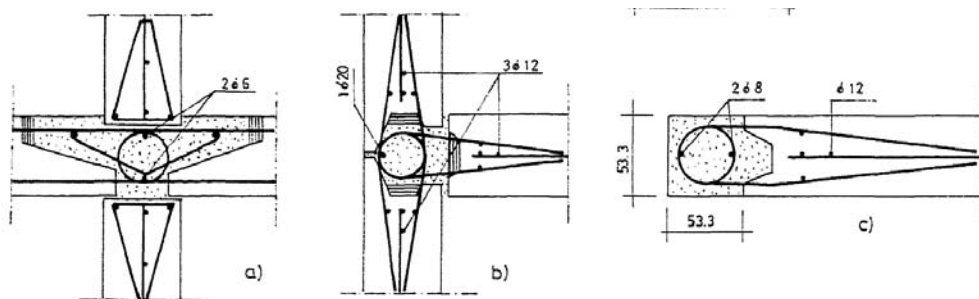

Figure 10: Detail of monolithic connection: a) Joint of vertical panels and floor slabs, b) Horizontal section of vertical panels' joint, c) Vertical connection of rectangular panel walls. (Velkov, Ivkovich, & Perisich, 1972)

Since the primary and secondary structures are separated, there is a certain freedom in using the system in spite of the limitations in the position of the supporting walls. In many cases, the façade as a secondary structure receives specific design and craftwork items. The large part of production of the façade panels was done on the building site, since they were produced by specific architectural design for each project.

The building envelope is composed of three types of panel components: 1- solid concrete panel; 2- door-window panel; 3- loggia parapets. Façade elements are three layered industrialized components (or

prefabricated on site): interior concrete 8.0 cm for non-bearing façade and 16 cm (19 or 22 cm) for bearing façade panels; thermal isolation 8.0 cm and exterior concrete 6.0 cm (Figure 11). The system catalog consists components for building structure as well as all the complementary components for the entire building: the panel for floor slabs, bearing façade, non-bearing façade and parapets, interior bearing walls and non-bearing partitions; installations walls and blocks; cornice, staircases, lift cores (Savov, 1983).

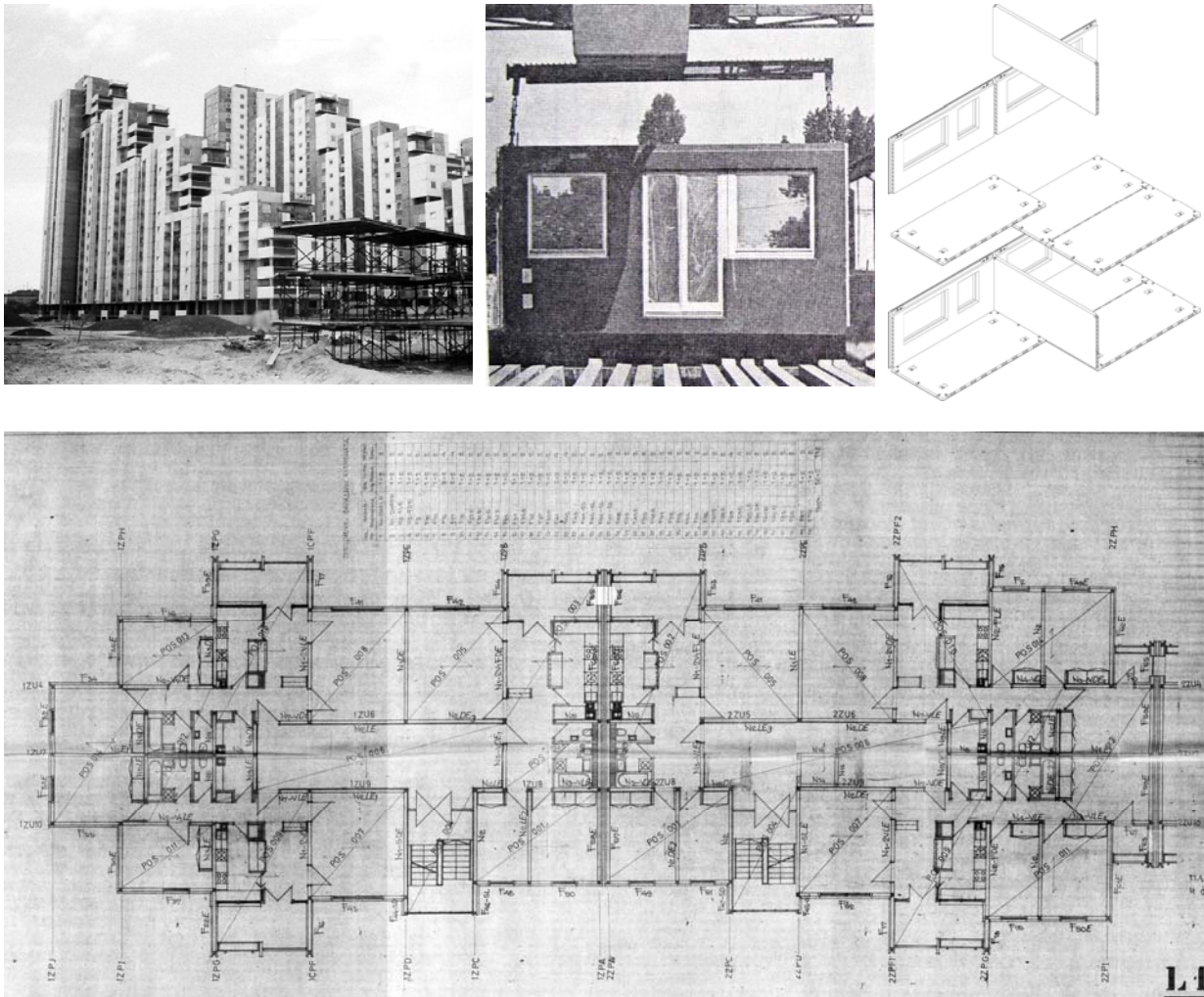

Figure 11: Block No.64 - Rad -Balency industrialized system applied for building structure (see: Appendix - Block No.64 : Building No.04 B1)

»Montastan System«

The large panel, high-industrialized system Montastan was applied in short period (1980-89). Around 5,500 flats were built using this unique system developed by domestic experts from the Institute for industrial building – Faculty of Technical Science Novi Sad and "1. Maj" Backa Topola. The system elements are prefabricated large panels (walls and floors) made of baked clay blocks strengthened by RC, stairs, elevator shafts and sanitary blocks. Montastan is a cross-wall bearing system applied with 3.6 or 4.2m span and constructive height of 2.9m.

The façade and apartments separating wall panels' dimensions are 3.6 (4.2) x 2.9m, 30cm thick, and the thickness of load-bearing internal wall panels is 22cm. All panels were finished in factory with mortar layer and double glazed windows or doors frames were built in. The partition walls in the apartments were made of 7cm thick brickwork. Floor slabs are grid RC components 20cm thick with clay blocks infill, dimensions according to construction span. Sanitary blocks were completely finished prefabricated box elements. The Montastan is recognizable by double pitched roofs (wooden construction covered with clay tile) and characteristically shaped loggias' openings. In Beograd housing its load-bearing system was mainly applied with complementary work for façade and roof done by different building technologies.



Figure 12: Montastan building assembly: construction in progress ⁴

»Trudbenik« system

Trudbenik system is a concrete large panel system with specific joints between elements (Figure 13). The system is vertically pre-stressed with cables threaded through supporting panel elements. It was used in the construction of the large housing project in Block 45 in Novi Beograd, and the knowledge based on this project was later used in building the Olympic Village for the 1972 Olympic Games in Munich.

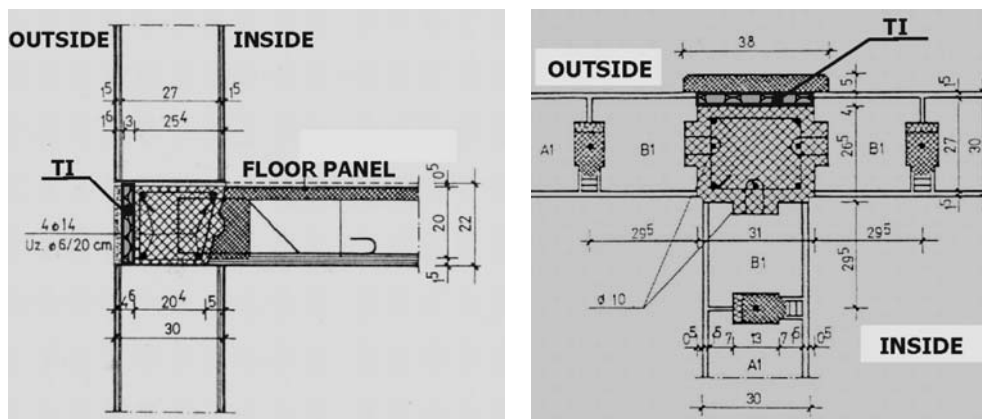

Figure 13: Trudbenik construction panel system: connection between façade and floor slab

⁴ Tehnički katalog krupnopanelnog sistema Montastan, str.14

Trudbenik system is a cross-wall bearing system. A façade may be done in a system, but a common solution is a façade system of prefabricated and industrialized components designed and built independently from the load-bearing system.

»Yugomont-YU61«

In 1961, one of the first large-panel systems developed in the country, the Jugomont YU-61 system, was used to build the building in Block No.28 (semi-atrium building). The buildings introduced a design that was typical for large-panel systems, with unique façades with different finishing, which was added to cover up concrete panels and insulation. The load-bearing structure is arranged with 3,60 m construction span of transversal panels (Figure 14). Later, the system was used for the housing projects all over Yugoslavia.



Figure 14:Yugomont YU61 large panel system - construction work in progress

3.2.2 Skeleton system: IMS Building Technology

The first industrialized construction technology, as an original product of domestic industry was invented in the late 40s. It was tested later in the 50s and then extensively used for the massive housing project of Beograd post-war regeneration. The first industrialized housing building was built in 1959 in Blok No.2 as an experimental work on site (Figure 15, left), which was designed at the *Institut za ispitivanje materijala* (*Institute for the Testing of Materials, IMS Institute*), by the engineer Branko Žeželj. Different housing buildings were built completely in the system from the components that were in the IMS catalogue sheets. In Beograd more than 22,000 apartments, of which over 15,000 in Novi Beograd, were built where the system was tested for the first time. More than 150,000 dwellings were built using the system. The IMS system was adapted for the construction of single and multi-family dwellings, from 2 to 20 floors (Giofrè & Miletić, 2012).

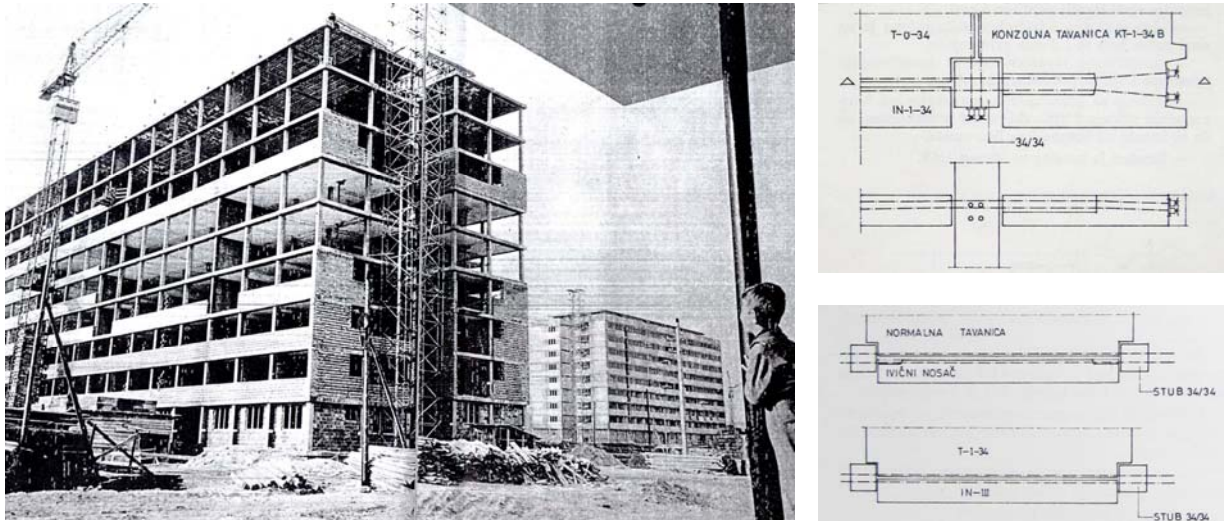

Figure 15: Block No. 2 - The first industrialized housing building - Corridor building (left); Slab-column post-tensioning process with steel cables (right)

The connecting of the elements of the primary concrete frame, made of prefabricated columns and slabs, was resolved through the application of steel cables aimed for the post-tensioning process (Figure 15, right). Complementary elements like façade parapets, interior partitions, utility works were installed while the assembly of the load-bearing system was still in progress (Figure 15, left), shortening the building process and enabling great organization and flexibility.

- **Technological aspects of Industrialized Precast System (IMS)**

IMS construction system is extremely flexible system composed of light elements of prefabricated prestressed concrete (Giofrè & Miletić, 2012). The skeleton system made of lineal elements in a larger construction span allows great flexibility since the façade and the partition walls are independent from the bearing system. The system flexibility can also be seen when looking at the data on its widespread use in realized and experimental projects in Hungary, Russia, Georgia, Cuba and Angola (Figure 16).



Figure 16: IMS housing in Cuba and Angola: building assembly process

The most favorable results are accomplished by standardized building elements for the construction of non-standardized housing buildings. Standardized IMS elements have been applied in various

combination sets and variety of configuration models to generate variety of dwelling layouts (Figure 17). Using the IMS catalogue components for the load-bearing system and different industrialized components and subsystems for the building envelope and interior partitions, the architect designed different dwellings' layouts. The building structure is physically distinct from the interior arrangement of the dwelling units which can satisfy the new requirement for adaptable housing. The interior organization of space and its parts may be changed many times throughout the life cycle of the building in which it is placed.



Figure 17: Variety of dwelling built in IMS construction system

The IMS structure was possible to close in different ways: classic (masonry) or different precast panels, which in fact were not part of the system. Different designers or construction companies applied different variants (Figure 18). A façade element in the IMS system, in relation to its form, can be divided into horizontal façade element-parapet and vertical façade element-panel. Further distribution of different elements is in the parapet premises (insulated) and parapet railings on balconies. The next division is between the solid panel, without holes, closed with full modular plane, and the panels with openings for façade windows which can be formed by cutting into the panel, or complete by cutting part of the panel. Accordingly, there are many examples of possibilities and versatility of the IMS system when it comes to the building design. That means that any type of local material or procedure can be applied in order to obtain sustainable, energy-efficient and cost-efficient housing. The IMS building technology has successfully been implemented in the production of high, medium and low-standard housing, in various parts of the world, for small individual houses, residential estates and commercial or public buildings.

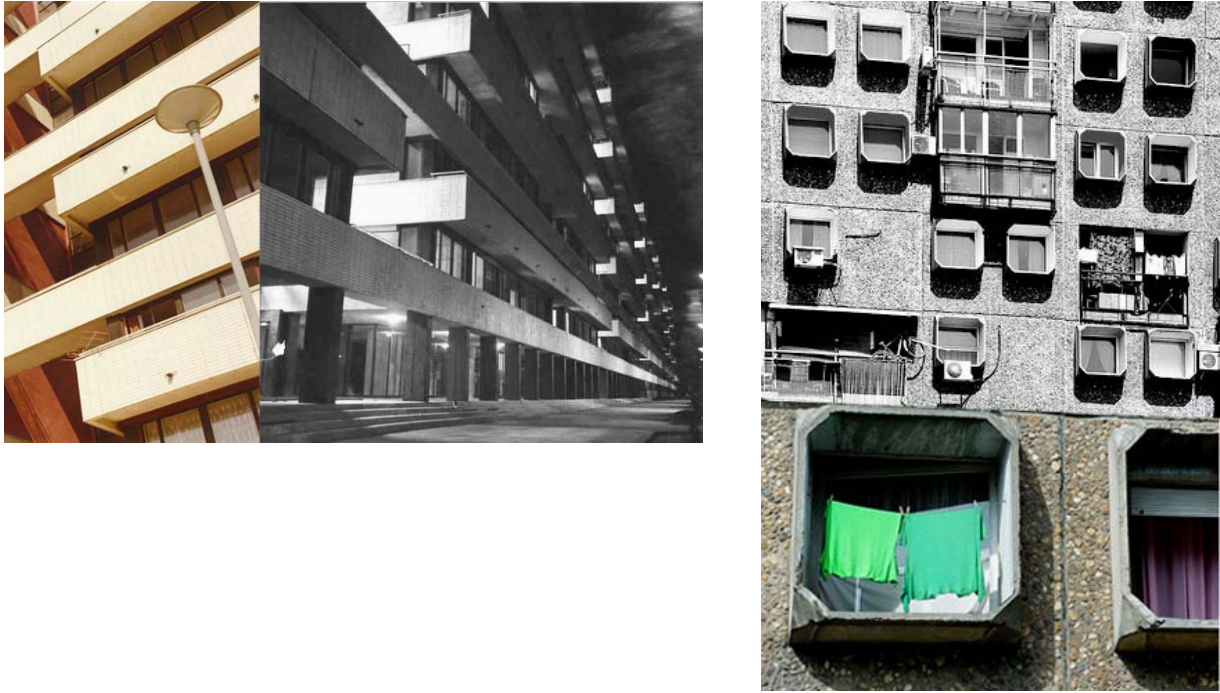

Figure 18: Different façade solutions: Building B9, Block No.21 (1960): Architects: Mihajlo Canak, Leonid Lenarcic, Milosav Mitic, Ivan Petrovic; Block No.28, 1974, Architect Ilija Arnautovic

The load-bearing structure (primary structure) consists of pre-stressed reinforced concrete elements - columns and slabs. The complete prefabricated concrete frame consists of columns, slabs, shear walls, edge girders and cantilever slabs form part of the main frame extensions. The IMS construction elements can be divided into two major groups:

- **Basic structural elements** which define building layout are:
 - **Columns**, continual through maximum 3 stories (depends on their cross-sections and storey height or possibilities of the crane used for erection), possessing square cross-section – dimensions: 30 x 30 – 60 x 60 cm.
 - **Floor slabs** cover the space between columns and can be manufactured with or without concrete ceiling, as one of the components (construction spans until 3.6 x 4.8 m) or multi-pieces aiming to adapt the dimension for transportation and erection (ceilings made for the span 9.0 x 9.0 m are constructed from nine standard elements); the marginal girder and waffle web height is 20-40 cm (depending on the column span between which the space is covered), the floor slab depth between coffer webs is 4-6 cm, and the ceiling is 3cm.
 - **Stiffening walls** are reinforced concrete panels (minimal thickness – 15 cm), which stiffen the frame. They are positioned along the axis of the two adjacent columns to form a structural element from foundations to the roof together with columns, ready to receive the intensity of horizontal loads (in practice, those elements are often set in concrete in situ, especially at larger spans for the reasons of huge dimension, weight and slow frame erection).

- **Cantilever floor slabs**, which replace edge beams in architectural solutions where balconies, loggias or other housing space out of column span are required and which are connected to two columns only (as a cantilever) and their height and length correspond to floor slabs, while their maximal width is limited on 1/3 of the span. They are waffled and can be with or without concrete ceiling.
- **Edge girders** have a boundary position in order to form frame beams and façade construction. Their lengths and depth are the same as the corresponding floor slab to form a frame beam and their width is chosen according to the architectural requirements for the adequate type of façade wall.
- **Complementary elements** are non-standardized elements and are defined according to the project requirements (choice of material and technical solution). Can be distinguished complementary elements for:
 - **Elevator manholes** – in practice those elements are set in concrete in situ, because of non-rational series (small number in relation with the mould price for manufacturing within the own section) which by the rule serve for the acceptance of horizontal forces together with stiffening walls.
 - **Staircases** are prefabricated for one-flight, double-flight or triple-flight stairs with monolith or prefabricated steps.
 - **Sanitary walls and cabins** are industrialized components ready to be installed in the building layout.
 - **Façade and roof panels** - the components for façade and roof define a envelope. They are not standardized, but IMS building technology offered the façade panel as standardized components.
 - **Partition walls** - this components were not standardized too. That means that any type of local material or procedure could be applied in order to obtain the interior space division.
- **IMS skeleton assemblage**

When building foundations are done with precisely left openings for anchors of prefabricated columns, multi-storey columns are positioned, fixed, with the help of braces, in vertical position and controlled with geodetic surveying instruments (verticality and axis position). Temporary capitals already exist on columns on which floor structure elements are erected – floor slabs, edge beams and cantilever floor slabs. Afterwards, floor slabs, are make monolith with post-tensioning using appropriate short cables obtaining the systems beams (Dimitrijevic & Gavrilovic, 2000). The joints between columns and floor slabs are filled in with mortar after which, the entire floor plane is post-tensioned with cables into two orthogonal directions. After this action, the braces fixing columns are released, the supporting capitals are transported to another storey and the operation of floor slabs erection is repeated. When prefabricated

panels are used as stiffening wall elements, they must be erected before upper floor slabs. If those elements are set in concrete in situ using portable formwork, those operations can be realized later, independently of the frame erection (Dimitrijevic & Gavrilovic, 2000).

Furthermore, available cranes are used for erection or auto-elevators in number and yield depending on definite building and location. An organized group of 5 to 6 workers with the crane-man can erect one storey level, about 600-1000 sq. m, which depends on the architectural building solution and the site (approach possibilities of the crane to the building, jagged building plan etc.), as well.⁵ Prefabricated sanitary cabins, sanitary walls - blocks are fitted into the basic modular grid system.

- **Choice of structural span**

Structural span is defined according to the needs of an individual design, considering the building function, transportation and erection. Rational spans are 2.40 m -7.20 m. The span choice is essential to determine the form and dimension of the other system's elements and the conditions in the building layout. Most of the housing buildings use the combination of different spans. The slabs have been combined into construction spans (2.4 x 7.2, 4.8 x 7.2 and 7.2 x 7.2 m), enabling architects to offer more variations in the building layout using standard structural elements. Smaller spans use minimal dimensions for the column section (30 x 30 – 40 x 40cm, for technological reasons), so they are convenient for medium-height housing buildings. Larger spans are appropriate for buildings which, besides housing, possess some other function – garages, offices, and do not need a large number of columns (cross-section 60 x 60 cm). Limited capacity of the buildings' cranes influenced the use of middle and small construction spans with the construction area between the columns from 15 to 18 m². According to the JUS.U.A9.001 had been applied a basic module of 10 cm (M) and design module of 60cm (6M) (Dimitrijevic & Gavrilovic, 2000).

3.2.3 Best practices of Industrialized Residential Architecture

The first residential blocks of Novi Beograd were built before 1963 (Blocks 1 and 2). At the time when Blocks 1 and 2 were designed (1958-59), the General Master Plan of Novi Beograd, the work of Branko Petričić, had already been presented (Topalović & Kucina, 2010). This Master Plan established the concept of spatial design which proved decisive for the further construction of the Novi Beograd. The concept consisted of residential blocks organized according to the 'Soviet model of micro-district'⁶, which in its further elaboration led to the construction of district centers and local communes – one for every 6000-10000 inhabitants (Jovanović et al., 2011).

⁵ Precast, prestressed concrete skeleton in contemporary building PRECAST PRESTRESSED CONCRETE SKELETON IN CONTEMPORARY BUILDING - IMS SYSTEM, Radovan Dimitrijevic, M.Sc., civil eng., Branka Gavrilovic, arch. , Belgrade 2000

⁶V. Bjelikov, Način stanovanja u Beogradu. Urbanizam Beograda 42 [Housing in Belgrade: Urban planning of Belgrade] (Belgrade: Institute for Planning the Development of Belgrade, 1977), p. 12.

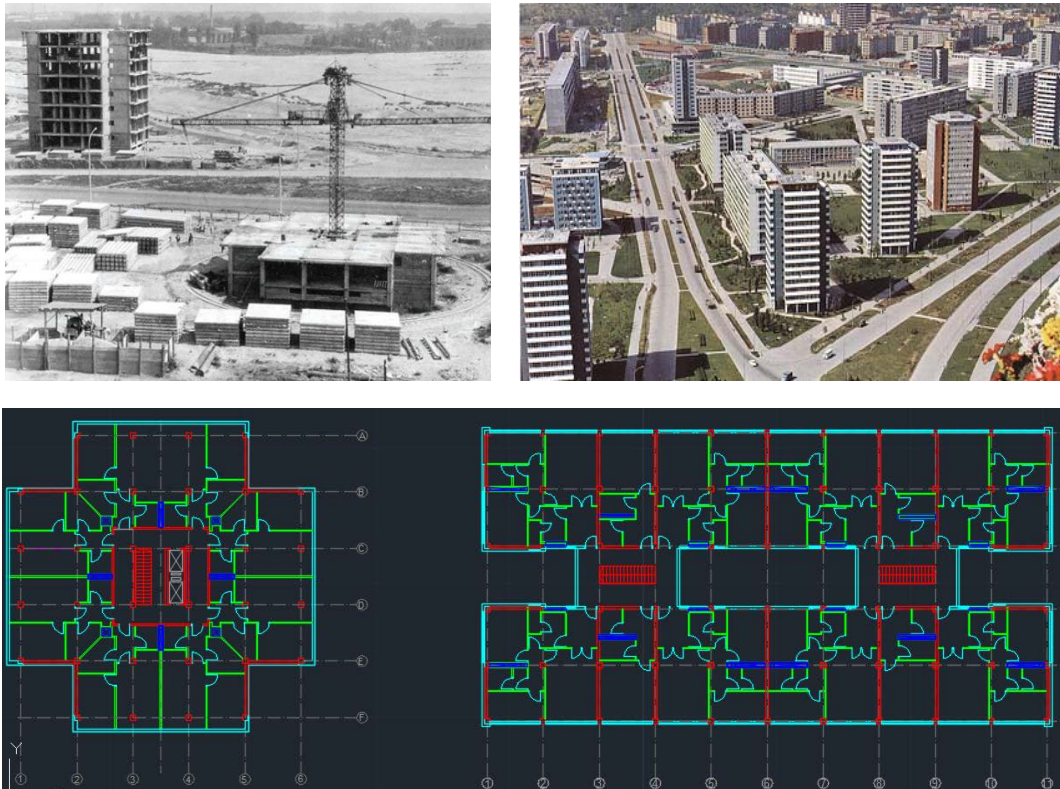

Figure 19: Block No.2- Industrialized housing in IMS construction system- building construction in progress⁷

Blocks No.1 and 2 were designed (1958-59). Two building typologies were built by the IMS building system at the beginning of long reconstruction process of housing in former Yugoslavia. Tower building and lineal blocks (condominium) were built "in the system" (Figure 19). All the components were in the IMS catalogue offer. A load-bearing structure is an IMS skeleton from columns and slabs. Reinforced concrete panels cast-in-situ are used for the horizontal loads. The building envelope consists of a horizontal composite parapet panel and a row window. The roof is flat, finished in bituminous material. Interior partitions don't receive any loads.

Block No. 21 in Novi Beograd was built according to winning competition design by Mihailo Čanak, Leonid Lenarčić, Milosav Mitić and Ivan Petrović in 1961, and the first one to show the versatility of housing typologies in the IMS construction system (Maric, Nikovic, & Manic, 2010). As opposed to the previous attempts in the IMS system, these buildings today represent the best of modern architecture in Beograd. Housing block 21 is the first one implemented in the central core of the Novi Beograd, according to the Master plan for New Belgrade in 1962. This block is the only one of nine blocks that were realized totally according to the plan, while the other 8 were transformed in their implementation.

⁷ source: Historical Archieve in Beograd



Figure 20: Block No. 21- IMS building technology for different housing typologies

Residential buildings in Block 21 present three compositional types: 16-story skyscrapers at the beginning of the block, 10-story longitudinal buildings along the main boulevards and 4- story building - meander in the middle of the block, in combination with low school buildings (Figure 20). Right now this housing block counts with 2312 dwellings and 7660 residents. It was built for the government and army employees supervised by communist party officials.

For the 10-story longitudinal building B9 and 4-story building Meander which cover 55% of the entire dwelling area (60% of all dwelling units in the block), the IMS construction building system was applied. 1420 dwelling units were built in these two buildings (Table 1).

Building name	Dwelling type and No.							
	S	1	1.5	2	2.5	3	4	SUMA
B - 9	2	18	-	600	-	6	-	626
A - 7	6	75	20	300	228	338	37	794
SUMA	8	93	20	900	228	344	37	1420

Table 1: Structure of dwelling types: S-studio; 1-one bedroom flat; 1.5-one and half bedroom flat; 2-two bedrooms flat; 2.5-two and a half bedrooms flat; 3- three rooms flat; 4-four rooms flat

Block No.23 was built at the same time as Block 22 by the same authors but in a different manner, due to the different contractors and much larger number of housing units. The main characteristic of this housing block is its diversity in volumes, contrast between the high- rise and low-rise buildings, the use of three different building systems (IMS, conventional skeleton systems) and with that the use of different concrete façade elements (Figure 21).



Figure 21: Block No.23 - Variety of prefabricated components applied in the façade

Block No. 28, designed by Ilija Arnautović in 1968, is the most basic example of the building in the IMS system but with an interesting use of the material for the façade. In a simple use of the IMS in the design of the building, "keramzit" (expanded clay gravel) was used as a material for the different façade panels. Because of these specific façade elements, the buildings are popularly called 'the TV buildings' Figure 22.



Figure 22: Block No.28 - TV buildings (IMS load-bearing construction system with "Keramzit" façade panels)

Block No.29 designed in 1968, by Mihailo Čanak and Milosav Mitić, shows a different approach to the use of the IMS system. As opposed to the previous example, the buildings here show the full potential of the system. The block consists of seven pavilions in slight variations in volumes and disposition. Over 130 different panels were used for the façades of these buildings in combination with the classic brickwork and some cast concrete walls.



Figure 23: Block No.29

Block No. 45 designed in 1965 with two types of buildings: that of Mihajlo Čanak (P+16), Grgur Popović (P+12 i P+14), and Branko Aleksić (P+6) for the skyscrapers, and that of Risto Sekerinski for the semi-atrium buildings (P+2 and P+4) (Figure 24). The so-called *Trudbenik* system applied for the load-bearing structure is a large concrete panel system with specific joints between its elements. This system is vertically pre-stressed with cables threaded through supporting panel elements.

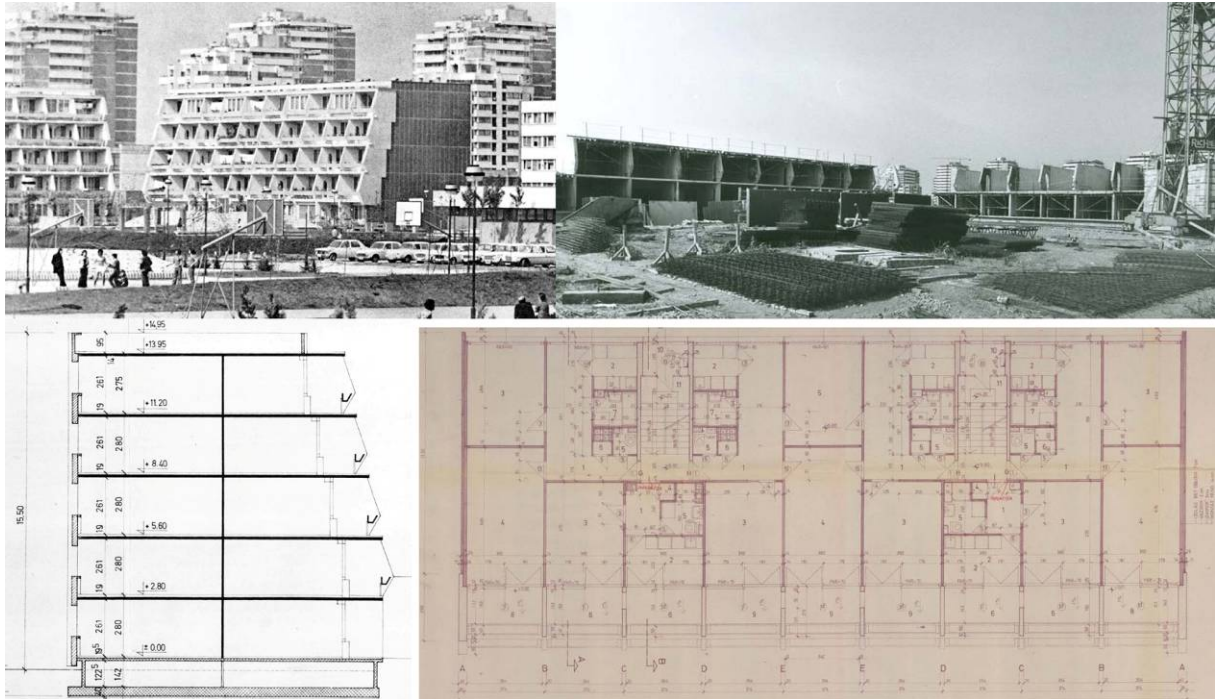

Figure 24: Semi-atrium building - *Trudbenik* prefabricated panel system (building construction in progress, see: Appendix - Block No.45 : Semi-atrium building)

Blocks No. 63 is located in line with Blocks 61-64, which are considered a brutal example of ‘inline urban planning.’ represent a massive housing project designed by three different prefabricated building systems (IMS, Rad-Balency and Napred-Dillon systems). Its author in terms of urban planning was Josip Svoboda. The architectural solution was the result of an internal competition launched in 1971. These macro-structures eventually obtained their characteristic stepped appearance.



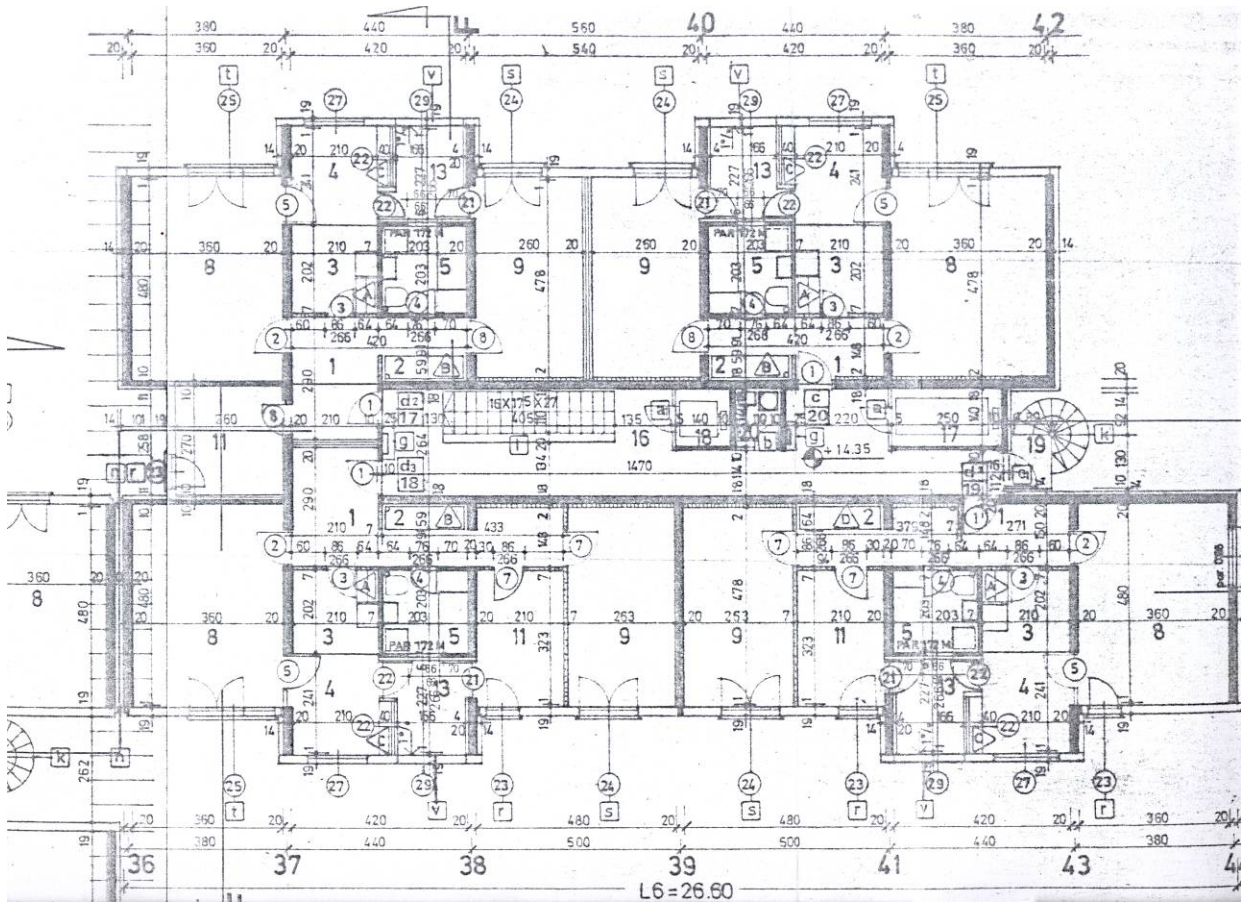

Figure 25: Block No. 63: Conventional reinforced concrete panel structure⁸

Blocks No. 64 represent a massive housing project designed by the Rad-Balency system. All of the high-rise buildings have similar volume but different elements within the façade. The investor was the Agency for the construction of Belgrade Federal Secretariat for Affairs of National Defense (SSNO).



Figure 26: Block No. 64: Rad-Balency huge panel industrialized system (fotos by Goran Jovanovic)

3.3 Building 'in the system'

The housing construction 'in the system' defines a method of design and building with the components and subsystems of one building technology (Figure 27). Building 'in the system' was applied for the first

⁸ source: Historical Archieve in Beograd

generation (1945-1955) of housing projects when the new industrialized systems had been experimented for the first time. Since the 1960's almost none of the Beograd housing projects were built fully *'in the system'*⁹ (Herold & Stefanovska, 2012). Different building technologies and prefabrication systems have been integrated and mixed in one building model, which defined a *'systems building'* method. A building process based on components and systems from the different construction technologies and different producers was dominant.

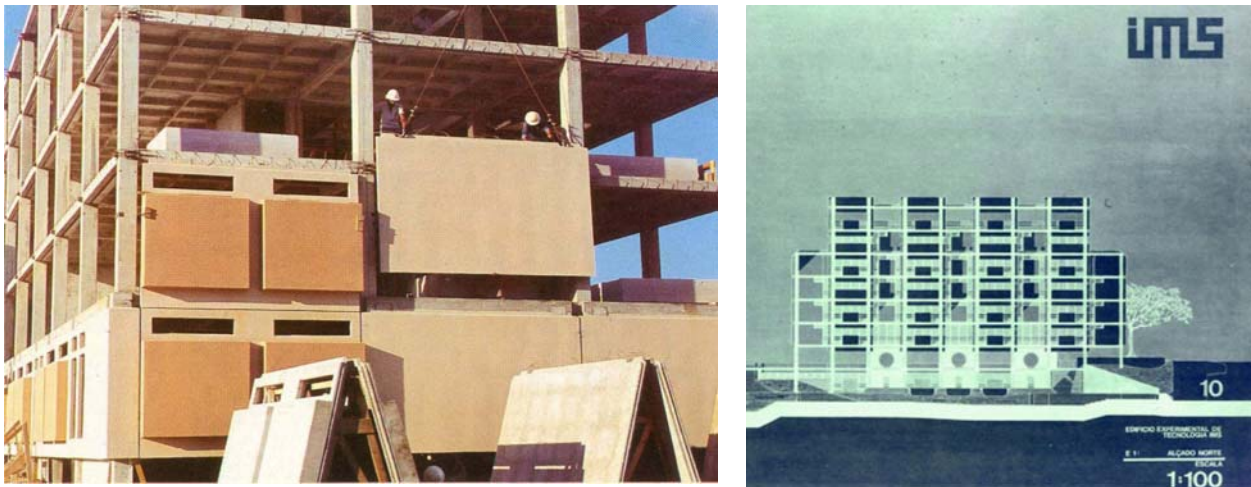

Figure 27: Building *'in the system'*: IMS Housing in Cuba¹⁰

3.4 Industrialization of housing: Building "with systems"

The real meaning of industrialized housing in Beograd should be understood through the definition of *'systems building'* model (American building practice, R.F.Borg, 82). Building by the systems is used to define a method of construction in which function is made of integrated structural, mechanical, electrical, envelop and partitions systems and subsystems, from different building technologies.

The systems building is applied to the industrialized housing in Beograd where prefabrication, standardization, and methods for production and quality control were central (Gann, 1996). In an industrialized post-war building renovation, the products were not buildings but mainly systems building. The systems building is a set of parts and rules where details are resolved so as to generate many different and customized buildings ((R. B. Richard, 2006)) and is described by:

- Structural type (skeleton frame structure, huge-panel structure, mixed structure);
- Structural order (technical and functional levels);
- Assembly order (group of elements-subsystems, sequences of elements);

⁹ (Herold & Stefanovska, 2012)

¹⁰ Experimental construction site in Luanda, Angola, designed by arch. Ivan Petrović; executed in IMS skeleton system. IMS Institute had supervised experimental sites all over the world as a significant part of the IMS prefabricated system exporting policy, (Jovanović et al., 2011)

An Industrialized Systems Building (ISB) implies maximal factory production, leaving only the final assembly to be done on site (although, in some cases the factory is brought to the site). The main parts of the systems building are the sub-systems, which generally correspond to the main functions of the building. Some components or sub-systems are often merged into a single element in order to simplify the operations while reducing the costs. For instance, a load-bearing sandwich panel might meet both structural and envelope criteria, a modular closet kit can be used as partition between two rooms of the same apartment when the appropriate sound proofing measures are taken, etc. Therefore, the construction method is not re-invented each time the building is planned, as it is still the case with the conventional way of building. Simple connections allow an integration of components and subsystems from different building technologies and different fabricants. Many systems can be added as sub-systems to reach different technical and functional scopes. Then there is the opportunity for many manufacturers to offer different options and participate in housing design and building process, as long as their dimensions and their interfacing details are compatible.

In order to evaluate the building structure as the systems model, two types of relations have to be considered: one between the subsystems and components and one within the subsystem. The type of connections is the principal condition in the systems model transformations. The more independent components and systems in the existing housing will be analyzed for planning an integrated refurbishment strategies for the upgrading on functional, structural and energy efficiency level. Systems architecture decomposes the problem as a whole into a hierarchical structure of functional subsystems which can be looked at individually at a lower level and cohesively at a higher level (Eppinger and Browning., 2012).

3.4.1 Industrial method of systems building

In order to avoid the structural dependences and to support more efficiency of the construction process, the technical levels such as the load-bearing structure, envelope, partition walls and are independent. Assembling of the building structure composed of prefabricated subsystems and components is defined through independent technical and functional levels. The levels are defined according to the changes of studied aspects (functional, technical, spatial, material...). The theory of levels introduces systematization of elements into a number of independent assemblies and relations between the fast changing and slow changing components to control the total building process and make faster housing re-building.

Considering the way systems and functions make relations in the built structures will lead this research towards the adaptability of the existing housing. The type of relation between the elements is significant for the systems transformations. Bearing in mind the level of functional, structural and physical domain in the structural configuration this research supports the development of the new integrated and intelligent solutions based on the new systematic approach for the massive structure upgrading that include: systems and components industrialization, re-assembly, decomposition and customization.

3.4.2 Mixed building technology

Except the IMS system, large panel system Rad-Balency, Yugomont and Trudbenik, mixed construction systems with sub-variants, and over 20 variations were developed and applied in Beograd. The conventional cross panel system was replaced with the prefabricated industrialized panel system and non-load-bearing façade. The new building approach took into consideration both: the adaptability of the built structure to the new requirements as well as technical, environmental and economic consequences that are related to its physical transformations. More independency between elements in the built structures offer more options for partial transformation in buildings. Mixed systems building were developed according to the requirements for more flexibility during the building process to support parallel assembly procedures for different building parts.

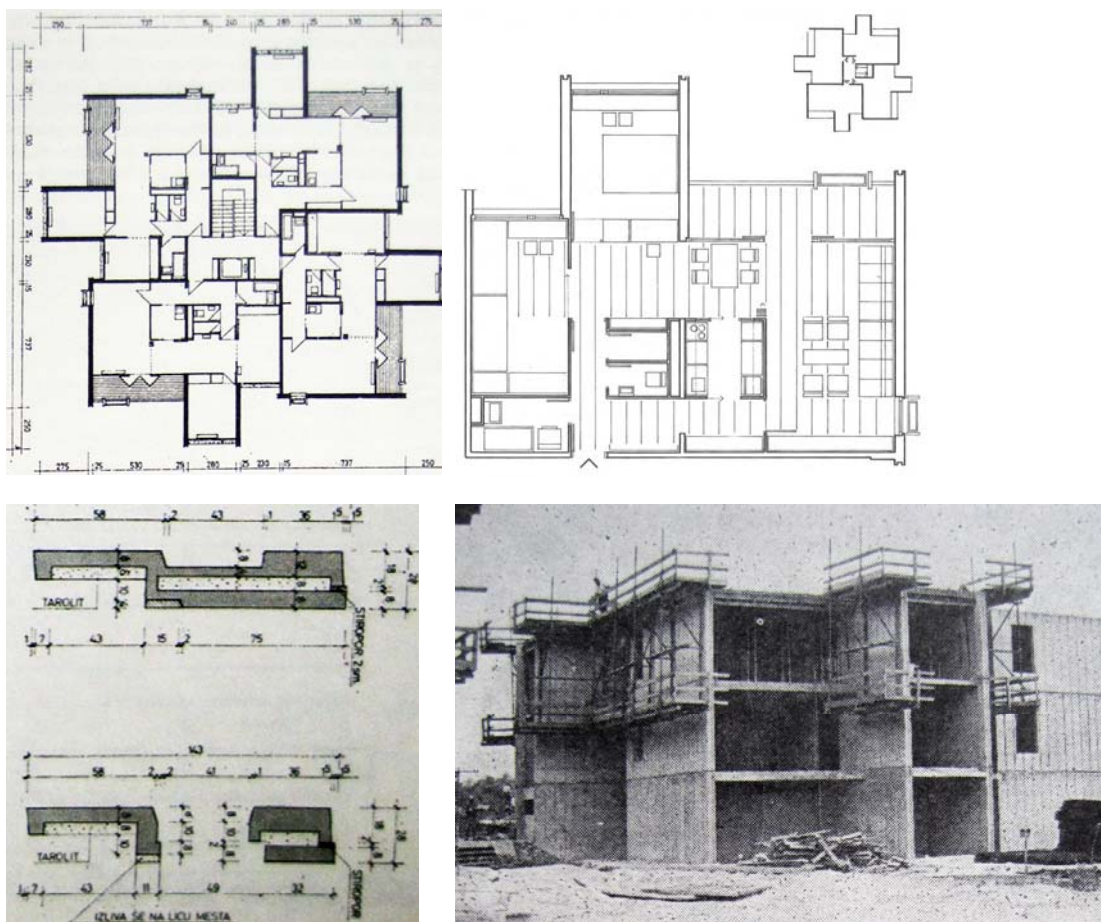

Figure 28: Block No.22- Mixed building system (see: Appendix - Block No.22: Tower Building)

Since prefabricated systems were being developed for decades (precisely in these large projects of residential architecture) and since the demands were constantly changing, each housing block and each building had unique features, according to the integration of different prefabricated systems and components. The development of prefabricated systems actually became a 'technology of prefabrication', which contributed to the fact that Yugoslav housing architecture was more variable.

Figure 28 presents mixed building model where different technologies are applied for different building parts. The tunnel formwork was applied for the cross bearing walls 15 cm tick. On this conventional bearing structure were installed precast prefabricated components (floor slabs, roof slabs, cornice, parapets, façade panels, staircases).

The tower building from in the Block No. 22 (Figure 28) highlights the values and constrains of the post-war housing industrialization. Design of the massive cross-wall bearing system comes from the dwelling units' design (Figure 28, right upper corner). Each flat in the typical floor plan has double orientation and flexible layout. Flexibility of the dwelling layout is supported with the construction span variations. Construction span of 2.80m , 4.20m and 5.40m is adjustable to the dwelling functions and the interior dwelling area is free from bearing partitions. The prefabricated slab (4 cm tick) with the ribs on each 52 cm were fabricated in to dimensions: 1.18 and 1.78 m long, in MB-300 concrete. Parapets for façade were fabricated in a variety of shapes 20cm tick (8.0 cm concrete, 8.0 cm isolation, 4.0 cm concrete), 1.73m high and long up to 5.16m.

Prefabricated slab	<ul style="list-style-type: none"> 4 cm tick with the ribs on each 52 cm were fabricated in to dimensions: 1.18 and 1.78 m long in MB-300 concrete
Façade parapets	<ul style="list-style-type: none"> variety of shapes 20cm tick (8.0 cm concrete, 8.0 cm isolation, 4.0 cm concrete), 1.73m high and long up to 5.16m
Prefabricated roof slab	<ul style="list-style-type: none"> 10 cm tick with the ribs on each 52 cm ;fabricated in the concrete MB-300
Cornice	<ul style="list-style-type: none"> 1.20 m high, 8 cm tick; fabricated in the concrete MB-300

Table : Industrialized components applied for the tower building in Block No.22

Along with the development of the system, the production technologies of components and components assemblies have been developed. The high demand in housing construction did not arrive to develop the production of "complementary" components always on the same level for each building because of short time schedules. That's why different building technologies have been combined for different building parts. Sometimes the individual works performed in the traditional manner were more economically favorable to improve the construction technology (semi-prefabricated partition walls, large formwork system, traditional brick wall parapets, etc).

The result of combining the evaluable building technologies within a single construction system, their diversity, is of special interest for the investigation.

3.4.3 'Open' prefabrication

The question to be answered is how the post-war industrialized housing technologies solved the problem of massive housing?

In the development of the technology of prefabrication, the system production was divided into the elements of primary structure (load-bearing system) and those of the secondary structure or (façades, installations and partition walls. The objective was to develop a building technology adaptable according

to the requirements of the specific architectural design. It was easier to control the building process by parts than a building as a whole. The primary structure had been a subject of the design process. The architect and engineers designed flexible structure to support flexibility of the dwelling space. Main criteria for the design of building structure are:

- i. A combination of the construction spans - different construction span was applied according to the different functional zones (*see: Appendix - Block No.22: Tower Building*);
- ii. The position of the load-bearing elements in the layout - for the flexible arrangement of the dwellings;
- iii. Load-bearing system is independent.

The plan of the load-bearing layout was an 'empty lot' for a flexible organization of the dwellings. The process of designing and constructing was 'open' and its participants cooperated very actively, often reaching specific technological solutions to adapt to the needs of the individual design. The 'design' of building structure was possible according to the modifications and transformation of the basic structural assembly. The IMS skeleton system evolved from a 3.60m range (*Appendix - Block No.21 : Building B9*) to that of 7.20m, with 2.10m consoles. Flexibility in the design and permanent technological improvement became the main strength of the IMS system.

We can emphasize that the Yugoslav building industry had created a methodology of '*open prefabrication*' for the massive housing design and building in accordance with the industrialized construction technology and individual housing design. Systematization of industrialized components and systems according to the main building functions supports more flexibility of housing. The development of industrialized technologies and systems prefabrication had been used for the design and assembly of housing. The Yugoslav industry set its own systematic approach on this prefabricated model, considering the prefabrication a multidisciplinary approach in which all professions would have an equal share. Until the mid-1980s, the performance of 57 local and foreign systems was comparatively analyzed and applied to different building parts, 20 of which were extensively used (Jovanović et al., 2011).

The same reasons that guided the segregation of the building process for different building parts will be used in the decomposition of the existing building structure for the analysis of the dependency conditions and connections between different systems and components. The type of joints and the components interface in connections will highlight the dependency conditions in the industrialized housing models. It appears that the opportunities created by adaptation outweigh those presented by demolition and rebuilding.

Structural durability by itself is not enough to ensure a building's longevity. In order to last, a building needs two types of adaptability. First, a building should be capable of adapting while retaining the same larger purpose. Second, a building should be capable of accommodating major shifts in functions (Boehland 2003). The more flexible the building configuration is the quicker and easier will be its upgrading. The embodied energy is in the connections, applied materials and production process.

"After choosing the width and depth on the basis of modular construction span and the shear walls position one can develop totally flexible layouts."¹¹ The main principles for a building structure design are:

- 'The configuration design' - the position, dimensions, composition, connections of systems and components is based on independent spatial, technical and material levels.
- The flexible distribution of the construction elements in the building layout allows for dwelling unit a number of different distributions.
- The possibility to change the surface of the floor plan, either by additional construction or changes in the boundaries of units out of the structure limits.
- The adaptability of structural configuration could be achieved by disassembly and reconfiguration.
- The connections between components in the configuration are based on simple joints.
- The connections between removable parts and load-bearing structure are based on simple joints.

Finally, the dynamic building structure designed and constructed for flexibility and transformation on spatial, technical and material level could be considered as a main issue for the housing industry to offer innovative approaches for more sustainable and green buildings.

4 Industrialized housing adaptability process

4.1 Influential factors and parameters for housing adaptability

4.1.1 Housing as the 'process' – Variables versus Constants

Housing life changes should be an updating process according to the collaborative work among all the participants in the housing building life. Understanding the industrialized housing as a '*process*' allows a better use of resources, thinking about the relations between elements and saving resources by making changes of the building parts suitable for transformation. The transformation capacity of components assemblies depends on how the components are put into connections and the type of connections. To understand the way the industrialized building configuration is assembled we will define the graph model in the next chapter.

Housing as the '*process*' is characterized by three main variables (Figure 29): i) changing dynamics in use and spatial transformations; ii) service and technical systems transformations; and iii) optimization of the building life circle impact and costs (Figure 29) (J. Nikolic, 2012). The dynamic changes in residential life versus massive buildings of post-war housing are withstanding a sustainable approach by inevitable transformations of the living space. Residents provide changes in their dwellings in different ways:

¹¹ J.F Berghoef, 'De N. -A.Woningen' Forum 10, (1952), 268

functional changes by making new divisions of the space and demolitions of the existing partition walls; replacing windows, division of the space for an extra room, joining action of rooms, etc. The transformations in the building layout for functional changes according to the inhabitant needs generate waste because components demolition (partition walls and embedded installation cables and pipes). An adaptability of the dwellings in Beograd has become a very powerful variable in the total building life. The major changes and negative impacts come from fixed connections between the structural components.

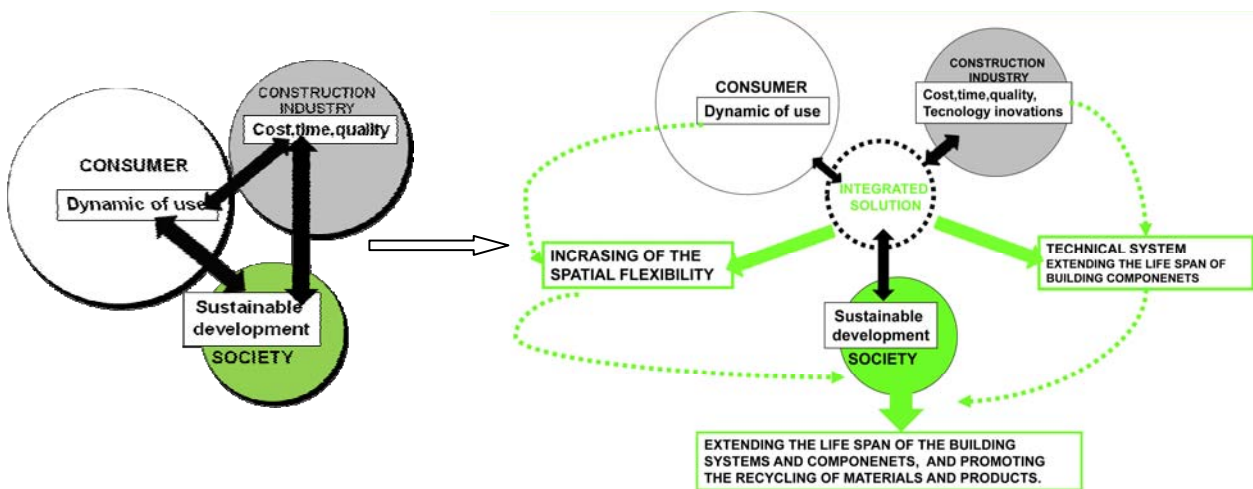

Figure 29: Three housing variables (left); Integrated solution for spatial and technical systems flexibility (right)

Dynamics in use

Different adaptations and changes of functional and technical systems for housing upgrading according to the new requirement define changing dynamics in use in the industrialized housing. A progressive diversity of the living systems needs more flexibility of the dwelling layout. Spatial and structural transformations depend on the flexibility of the building structure, applied technology and how the more permanent building parts (load-bearing structure, façade, services) are connected. The way of assembly of industrialized systems and components into building models influence the transformation capacity of housing.

➤ Industrialized systems transformations

Homes often suffer a transformation due to the degradation of more dependent materials and components by frequent changes of the user's needs and the technical systems upgrading. Conventional building is inflexible in the service phase due to the: massive structure and mixed functions; inflexible and fixed connections; and the lack of accessibility for the components with the shorter life-cycle. For this reason, the structural transformation is related to partial or total demolitions, significant loose of energy, materials and waste production. Although the building life is between 50 to 70 years (Gijsberg et al., 2005), it is evident that the lifetime is much shorter because of the fixed connections between building components. The uncontrolled overlapping of functions and systems, in the building structure results in very high adaptation costs and a negative environmental impact by demolition waste. To remove the interior walls

for the functional upgrading of space, the conventional system undergoes the process of walls' demolition. The first step to handle the temporal tension in construction is through the independence and exchangeability of the fast cycling components. After each phase of use, an industrialized system configuration should be designed and built to indicate the building suitability for the new changing requirements. 'Closed' system configuration and fixed connections between components are the principal reason for the low level of housing transformation capacity.

➤ **Building life-cycle impact**

An increasing number of buildings that face the critical issues (an expensive reconstruction or demolition) produce an enormous amount of waste, energy consumption and CO2 emissions. The key issue of construction sustainability is planning of integrated refurbishment strategies to upgrade inflexible building structures. An assembly and disassembly of building structure is the principal condition for the upgrading of systems and functions. A demountable structure may last longer due to the fact that its parts can be exchanged (removed, added or replaced...), so the housing could be adapted to the new life requirements. The main issue of sustainable development is to find the balance between the dynamics in use, adaptability of buildings, economy and the fundamental principles of environmental ecology by providing more transformation capacity of industrialized and prefabricated system configuration.

4.1.2 Contemporary Housing Requirements – IFT housing

In the post-war housing revitalization industrialized building technologies were used to replace the conventional construction process and to reach better quality and lower costs. The flexible models facilitate changes over time of spatial and technical systems and transformable - 'open' access configurations meet the new requirements for systems transformations without demolitions. Industrialized, Flexible and Transformable (IFT) housing is a precondition for proper selection and identification of the best refurbishment scenarios for the existing buildings. To describe IFT housing models will be analyzed:

- Model composition based on industrialized (semi- prefabricated or prefabricated) components, subsystems, systems, 'cast on site' elements and the connections between them;
- Independence and exchangeability of the structural elements to highlight the possibilities for building transformations;
- Identification of more flexible joints to be used for building upgrading; reduction of the fixed connections for simple and demountable dry joints.

What we will need to avoid the limits of massive housing is: "new method for mapping the interactions between the elements out of which the buildings were built, and the control that may be exercised over them"(S Kendall, 1987). Finally, the improvement of building capacity to adapt to spatial and technical changing requirements and consequently extend the service life of the building and its systems has been considered as a key issue for the sustainability in the construction.

- **Industrialized, Flexible, Transformable (IFT) system**

The future vision of multifamily buildings is to satisfy the needs for dwellings' adaptability and buildings' transformations on technical, spatial and energy efficiency levels. J. Habraken divided the building in 'support' and 'infill' and established the method for design and construction of 'support' as an independent technical layout (Habraken & Ramón, 1975). The IFT (industrialized, flexible and transformable) system is an extended approach of Habraken's 'support-infill' method to be applied to the upgrading of building functionality by more transformation capacity of system configuration composed of industrialized components and subsystems. The IFT model will improve the construction industry to be more customer-focused and to permit more dynamics in the building use (Figure 30).

The focus is on IFT integrated approach for industrialized, flexible and transformable system configuration to extend the total life span of the building structure by spatial and structural systems transformation (Figure 30). **Industrialized** – to adapt the process to the flexibility issue, simplifying the production to gain high quality and lower costs and offering an individualized finished product; **Flexible** – to accommodate changes at the dwelling level without destroying components and subsystems; **Transformable** – to remove the building components or subsystems without demolition.

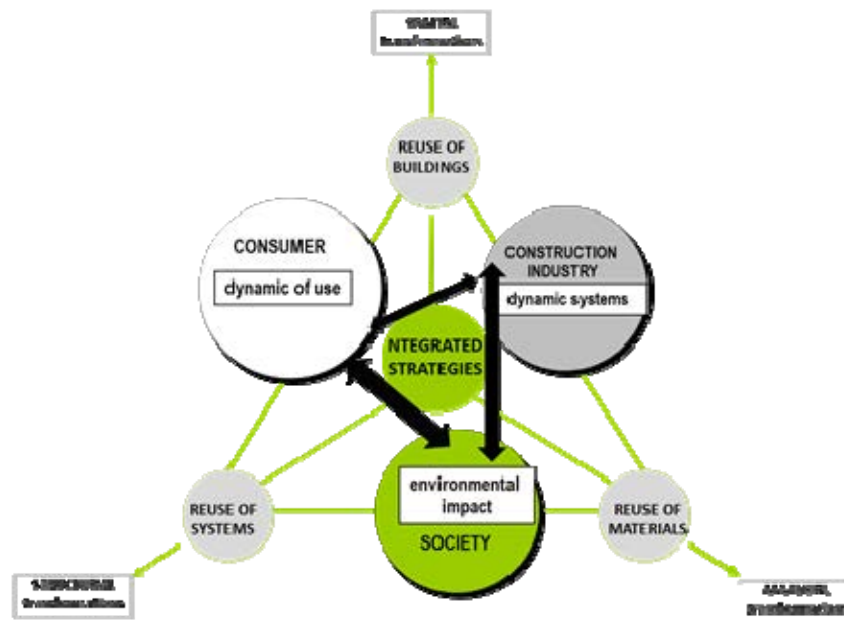

Figure 30: IFT integrated solution and main objective

For a high level of industrialization and transformation capacity, factory-made components can incorporate the precise details required for adaptable housing. Totally demountable building system comprises of a set of compatible and interchangeable components. To extend the housing service life, it is necessary to monitor the structure's performance through regular inspection of deterioration and other defects, investigate and detect the emerging problems and control the appropriate maintenance works, as well as to make possible transformations of buildings.

4.2 Spatial and technical flexibility and adaptability

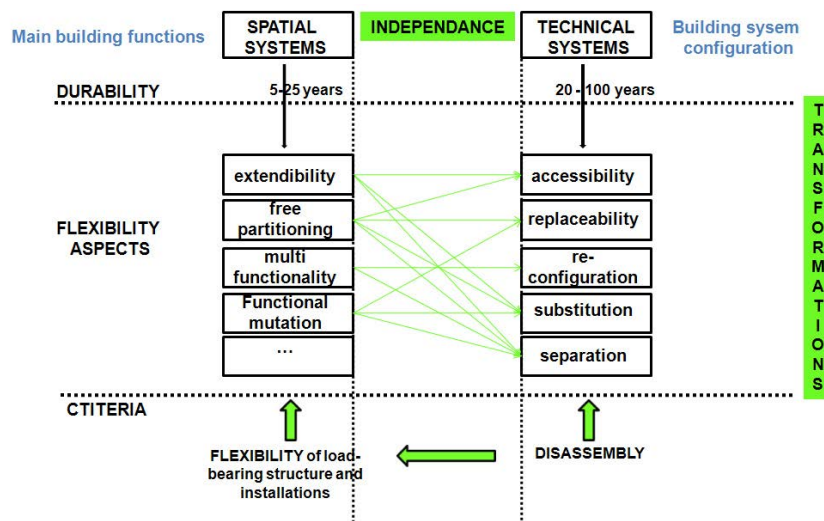

Figure 31: Relations between technical and spatial systems (Source: modified from Elma Durmisevic, 2006)

Two factors that initiate transformations in housing building are: the inhabitant needs for functional upgrading of spaces and the structural components to be replaced and reused or recycled at the end of life span. The dynamics in use and functional changes depend on flexibility of the technical system configuration. The term transformation is introduced to meet changing users' needs for special transformations and to meet the changes in the building configuration, respecting the systems and components with the different life span. Transformations of spatial and technical levels depend on the transformation capacity of the system configuration (Figure 31, Figure 32).

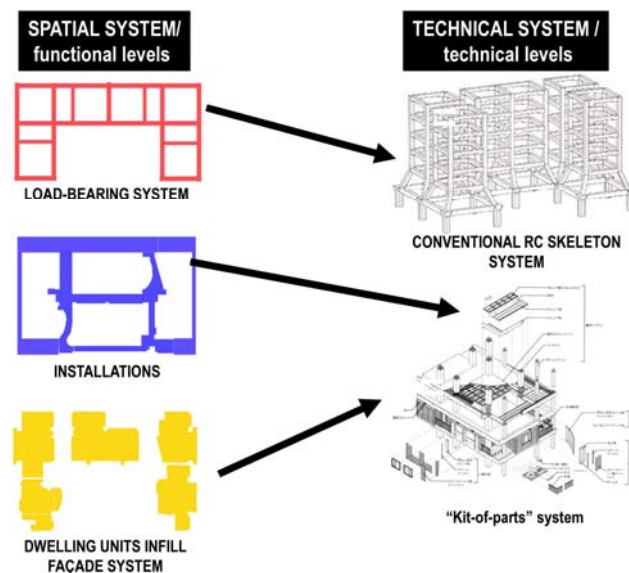

Figure 32: NEXT 21 Technical and special system (see: Appendix - NEXT 21 Open Building experimental project)

Two main concepts for massive housing transformations are: flexibility and adaptability of system configuration.

- **Flexibility**

Flexibility refers to the idea of accommodating changes over time. Flexible housing corresponds to “housing that can adapt to the changing needs of users” (Schneider & Till, 2007). In N. John Habraken’s words, *‘flexibility’* of residential space stands for “a new and challenging kind of residential architecture”(Nascimento & Habraken, 2012).

The English colloquial usage of the word *‘flexibility’* is the capacity for ready adaptation to various purposes or conditions. In its ordinary usage, *‘flexibility’* denotes not only a spatial-functional change, but a also physical change, modification or adaptation, for a variety of purposes or uses. The word *‘flexibility’* points out: the quality of being adaptable; the capacity of being adapted¹².

The organization of the rooms, their dimensions, the relation between the rooms and their functions are the concern for flexibility and adaptability of spatial systems. The flexibility of the spatial systems is required to provide the flexibility for a final user and his requirements. To sum up, Rabeneck, Sheppard and Town claim that “while the design decisions about the structure and service spaces are related to flexibility, the consideration about the architectural layouts of the remaining spaces is associated with adaptability” (Larson, Intille, McLeish, Beaudin, & Williams, 2004).

- **Flexibility of the building structure**

The flexibility of a building structure or structural flexibility is a property of buildings which greatly influences the service life of the existing housing. To specify and quantify structural flexibility in more details, a new definition of structural flexibility and structural adaptability is proposed for the industrialized housing in Beograd. The method to evaluate structural flexibility is based on the industrialized building model description. Key factors and indicators for structural flexibility will be analyzed in Chapter 5 .

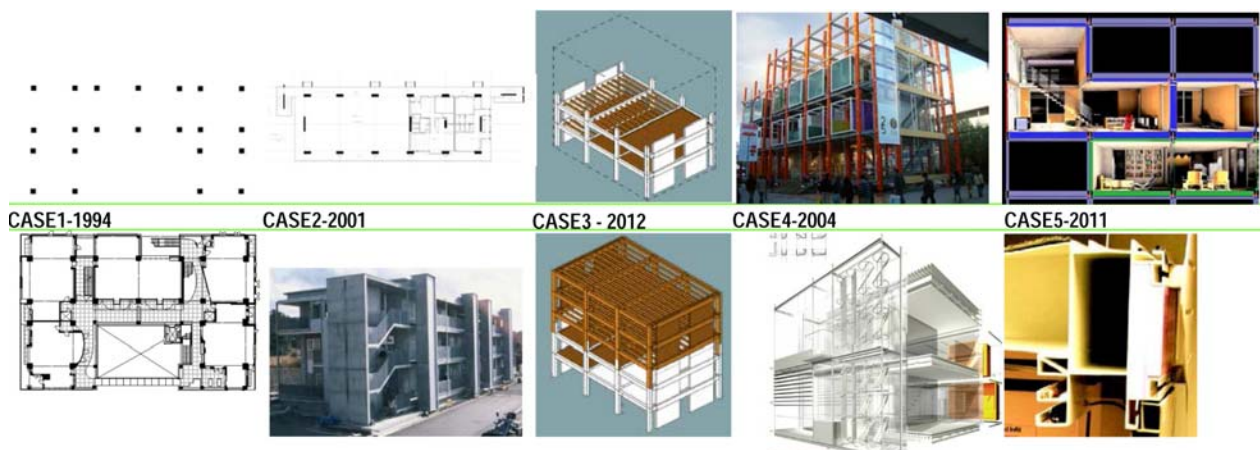

Figure 33: The Flexible Housing Primary Structure: Integrated systems for load-bearing structure

¹² Oxford English Dictionary Online, 2010

Figure 33 shows the flexibility of the housing load-bearing structure. In case 1 and 2 load-bearing structures are designed to support flexibility for the arrangement of the dwelling units. The load-bearing structure is a reinforced concrete skeleton with a variety of dwelling unit organization. Case 3 is the mixed wood and concrete load-bearing system that can be transformed according to the demountable dry-joint. Case 4 and 5 are IFD (Industrialized, Flexible and Demountable) building models. Main building subsystems (load-bearing system, façade, services) are completely demountable “kit-of-parts” systems. Case 5 is an experimental N-house where a 'chases component' is used as both - a load-bearing component and a shaft for the installations. Integration of different functions (ductwork, power, signal, plumbing connections, mechanical attachments for infill, HVAC systems, floor finishes, and ceiling finishes) are placed and connected through the chases.

Most of the industrialized building systems applied to the massive housing blocks in Beograd will be analyzed for flexibility and transformations at the different technical levels. The next conditions must be met: i) simple joints and ii) the adaptability framework. The joints are essential for the systems transformation at the end of the service life. Adaptable framework refers to the building structure transformation capacity for a variety of dwelling layouts and its adaptability. Industrialized framework is built to permit a variety in the use of architectural layout. More flexibility within the domestic use and highly adaptable layouts allow the occupants freedom to adapt flats and make transformations.

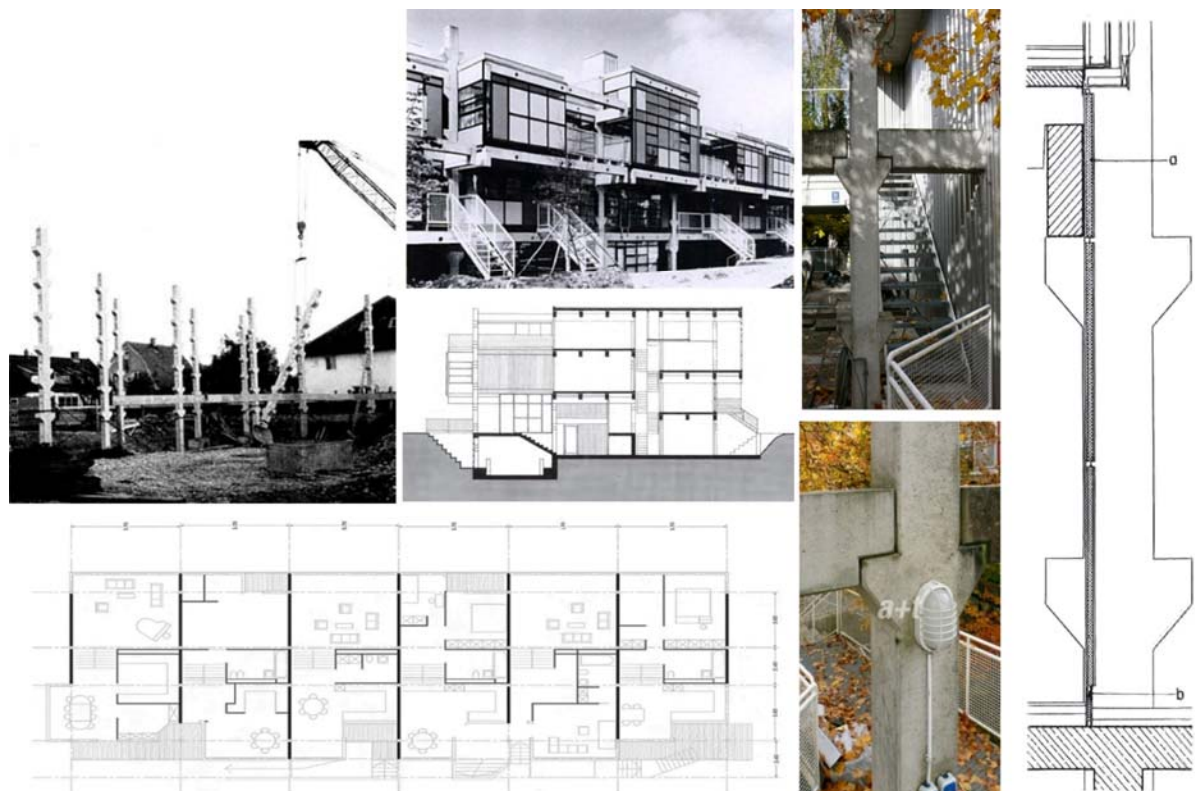

Figure 34: Genterstrasse_ Munich_ Otto Steidle_1972: A detail of the column with the corbels (see:Appendix - Open Residential Building - best practices)

In Figure 34, Otto Steidle applied the concrete skeleton of columns with longitudinal beams and supported floor panels. These frames can be combined with different construction spans and then multiply. The columns are the keys that share the loads and support the beams to form the skeleton. More flexibility is achieved by two levels or 1.5 ceiling height by corbels placed at every half-height of the column to be used for the extension of the structure for the new dwelling units.

We can distinguish four flexibility levels in industrialized housing design and building process:

- **Initial flexibility** is flexibility in the building layout for the typological variety of dwelling units (Figure 35). It offers a variety in the architectural layout of the dwelling units inside the building framework.

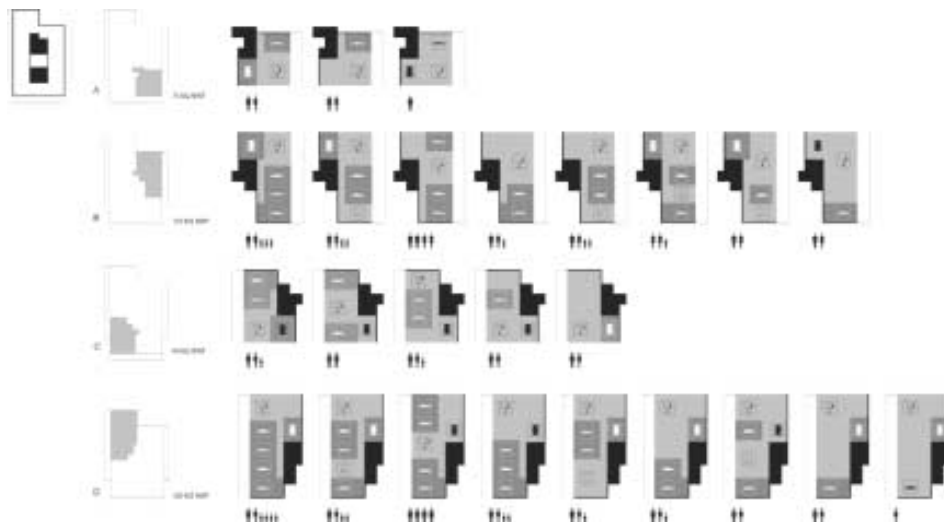

Figure 35: *Siedlung Brombeeriweg, Zürich, Switzerland (architect: EM2N Architekten, 2003): Transformations in the dwelling unit's layout (Schneider & Till, 2007) see also: Appendix - Open Residential Building - best practices*

On the Figure 35 twenty-five scenarios show the variability in the plan achieved through the internal rearrangement of walls. This potential makes it possible for the building, to react to the changing needs of new and existing tenants.

- **Progressive flexibility** is an opportunity for adaptability of the dwelling unit on spatial and technical level. Figure 36 presents Next 21 unit transformations independently from other units and independently from the building structure. In the concept of a flexible building structure, all the construction components, except the basic skeleton are pre-fabricated, and modularly designed including the partition walls, floors, ceiling and façade cladding.
- **Full potential flexibility** means full potential for constant changes in dwellings by changes in the boundaries of the building structure (flexibility of “support” for the adaptability of the „detachable unit”¹³). Changes of the primary by adding of a new balcony structure to the existing building were applied as well as functional changes of the dwelling space by removing the

¹³ (Stephen Kendall, 1999)

partitions walls. In the Figure 36 the full potential for flexibility is achieved by changes of all mayor subsystem except the load-bearing structure.



Figure 36: NEXT 21 dwelling transformation: Transformations of the mayor functional end technical systems: façade perimeter, façade cladding, kitchen and bathroom position, partition walls changing position

4.2.1 Spatial and structural flexibility of industrialized housing in Beograd

For industrialized housing adaptability process the following flexibility levels are significant:

- **Structural flexibility** (flexibility of the structure), a variety of choices for the construction span followed by variant solutions of systems complementary elements shape and assembly. The structural flexibility with associated disassembly options of fast cycling components can be seen as a key for sustainable refurbishment of industrialized housing. There is a natural interdependency between the structural flexibility and spatial flexibility. Structural flexibility is a condition for special flexibility. Structural flexibility is related to the ability of building components and systems to be easily replaced, reconfigured, reused, or recycled. The indicators of structural flexibility are: accessibility, reconfiguring, separation.
- **Spatial flexibility** (flexibility of space) is a possibility for different spatial organization within a dwelling unit or building layout, which should be realized during a design, construction or exploitation. Indicators of spatial flexibility can be defined as: an enlargement of the dwelling space; a rearrangement of partitions walls; the functional changes, etc.
- **System flexibility**, defines the flexibility of the mayor subsystem and systems in the building structure. The systems flexibility is a conditions for structural flexibility and enables efficient building changes within the phases.

Spatial and structural flexibility of the existing housing stand as a main issue for the industry to offer innovative approaches for refurbishment of the dwelling units. The IMS skeleton system had a privilege at the structural system choice because of the lowest limitations for the architectural design. The system enables flexibility and varying of architectural solutions, minimal material consumption, and easy prefabrication (the weight and components dimension can be adapted to transportation limits). Façade

and interior partitions are non-bearing parts in the building structure. Flexibility in the industrialized housing will provide efficiency and a variety. The word 'variety' is a tendency to change; change of purpose or content, a different form of something (*Oxford English Dictionary Online, 2009*).

4.2.2 Indicators for structural flexibility

According to structural flexibility definition we will look for the main qualities and indicators for dwellings' transformations. We will analyze the building, its composition and relations between its subsystems. The relation between the load-bearing system and other systems (envelope, interior walls) is examined. An analysis is based on:

Step A: Is the load-bearing system entwined with other building systems and type of connections?

Step B: The structural quality of providing sufficient space to each of the other building systems (façade, installations).

Step C: The aspect of providing sufficient load-bearing capacity for dwellings changes.

A load-bearing capacity together with a high degree of separation from other building layers result in a high flexibility level. In the Figure 37 the Next 21 dwelling unit is presented through the independent functional and technical levels. A variety of functional schemes in the dwelling layout is obtained according to sufficient load-bearing capacity. Dwellings' installations (ducts, pipes, and wiring of mechanical systems) are placed in the suspended ceiling, which allow the flexibility in position of kitchens and bathrooms. In order to achieve structural flexibility the other building layers should not be physically entwined with the load-bearing structure. At the same time the structure should accommodate the other building layers as much as possible.



Figure 37:: Next 21: Independent subsystems at the dwelling level: **A** - load-bearing module; **B** - envelope cladding, doors and windows; **C** - interior partitions, fittings, interior finishes, the doors and windows; **D** - dwellings' services: ducts, pipes, and wirings.; **E** - equipment, furniture. (Appendix - NEXT 21 Open Building experimental project)

Separation of different technical levels allow for the building services to be distributed independently from the load-bearing structure. This is very important issue for the future developments toward

transformation capacity of multiunit housing. The objective is twofold: first is design and construction of Industrialized, Flexible and Demountable (IFD) systems building; the second is adoption of the optimal design solution for integrated service systems. A very clear example of this independence and integration at the same time can be seen with the design of new Industrialized, Flexible and Demountable (IFD) floor systems (Figure 38). Its application results in changing positions of wet points (kitchens and bathrooms) anywhere in the dwelling floor plan.

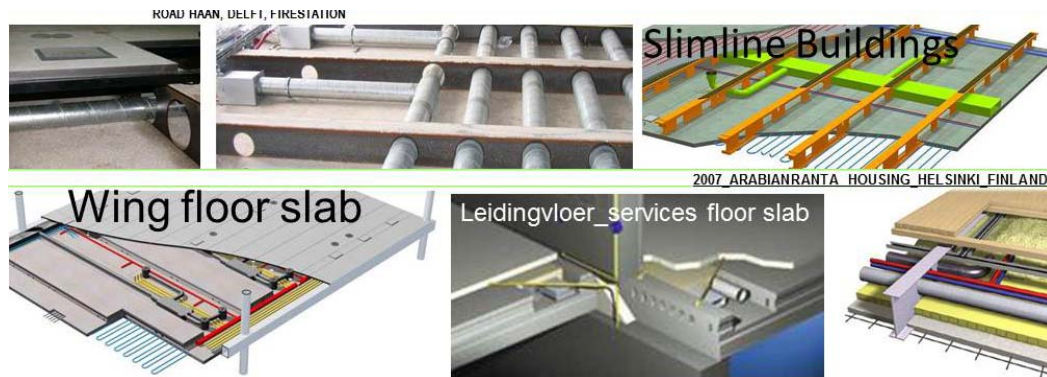

Figure 38: Integrated installation systems

4.2.3 Adaptability

In industrialized housing discourse, 'flexibility' and 'adaptability' are defined in different ways. The systems flexibility is a conditions for spatial adaptability. The adaptable approach to housing emphasizes both: adaptability of building structure according to changing requirements and adaptability of dwellings. It is based on carefully considered variations in room sizes, the relationship between the rooms, slightly generous openings between spaces and "little over expression of room functions" (Rabeneck, Sheppard, & Town, 1974, p. 86). Adaptability at the room level strongly depends on the adaptability of technical levels, the possibility to move or exchange structural components.

In general, the need for functional changes goes in two directions: a) enlarging space in a single dwelling by joining rooms and rearranging dwelling layout; b) joining the adjacent dwelling or their parts (with layout changes).

Parameter	Ground Floor Condition	Upper Floor Condition
Proximity of blocks	Determined by fire regs	18-21m min between habitable rooms
Plan depth	13.5m (preferably 15m) to 45m	15 to 21m
Internal ceiling height	3.5m single storey; 5-7m double storey	~2.7m
Ceiling zone	0-500mm	0-500mm
Floor zone	Preferably 100 to 350mm	Preferably 100-350mm
Structural slab and spans	Min 7.5m span 260mm slab @9x9m; 330mm slab 12x9m	Min span; max 12m span 260mm slab @ 9x9m; 330mm slab @12x9m
Fire design occupancy	1 person/5sqm	1 person/6sqm
Travel distances for fire	30m 2-way (12m 1-way)	30m 2-way (12m 1-way)
No. and size of lifts	N/A	Design for mixed use as worst case and offices as worst case for single use
Cladding spec.	Maximise glazing within fire, noise and cost constraints	40-100% glazing. NR 20-30; 1.5m module & option for opening casements

Figure 39: Summary of the adaptable building requirements (Gregory, 2005)

- **Strategies for building adaptability**

Main strategies to upgrade the adaptability of the existing housing will be based on the building model flexibility and transformation capacity. Decomposition of the building model into subsystems and components according to the main systems and components allows for a building to be technologically flexible. The subsystems and components can be modified with improved autonomy. The transformations at the dwelling level depend on dependency conditions of more permanent systems: load-bearing system, building installations, interior walls and installations. Gregory defines adaptable building requirements for more permanent building parts (Figure 39).

4.3 Industrialized housing transformations

4.3.1 Different levels of transformations

The transformation is every change of the building layout or its structure. The multifamily housing transformation -T can be defined as a sum of independent dwelling unit's-transformations (t).

$$T(\text{constant}) = t_1 + t_2 + t_3 + t_4 + t_5 + \dots + t_n \dots n\text{- number of dwelling units}$$

We can discuss different levels of transformations according to the needs of different participation groups and different technical systems. To satisfy diverse requirements, it is necessary to plan refurbishment scenarios based on the integrated strategies for the different levels of a building composition (functional and technical levels). The possibility to transform the building structure and layout depends on the joints technology and functional independency of the components. The '*Massive housing*' models, where all building parts are joined together, don't support a transformation without demolition, while '*Open Building*' system based on the independent technical and functional could be transformed levels (Stephen Kendall & Teicher, 2000). The structure is designed to withstand changes in the building layout different than the initials in the event that the new growth is made on the existing structure (*see: Appendix - Open Residential Building - best practices*).

The final goal is to achieve transformations of a dwelling layout by occupants according to flexibility of the mayor systems (load-bearing) for lower level transformations. The building facilities must be able to supply a growth of the new spaces and for the new facilities to be installed. The principal strategies are mentioned:

- An external growth of initial structural module for the surface enlargement - allows the growth of the dwelling. The new spaces can be created on a new outer support. It may be annexed to the initial volume by an assembly of new elements. This will be more suitable for the low-rise buildings, 4 to 10 floors.

- The expansion of housing may consist of building a new floor by adding attics, adding a cantilevered space, etc. This strategy is complex to implement because it requires the intervention of several actors in addition to the user and an intense external control applied by different agents such as the administration or the homeowners.

A system capable of major reconfigurations or even of disassembling will be considered '*transformable*'. Some of the independent sub-systems will be involved including the bearing structure. The transformable systems can be changed on the different levels. A separation of a load-bearing system, façade and partition walls support the transformation on façade level as well as at the levels of the interior space division.

4.3.2 Transformations of dwelling layout

The most common functional transformations of industrialized housing in Beograd have been undertaken in one-bedroom apartments. The residents themselves started with changing room function, variations in room sizes and the relationship between the rooms. The transition from a one-bedroom apartment to a two-bedroom apartment is very common. In Figure 40 we can observe that the kitchen and the dining-room have changed the positions to be a part of the living area and to obtain another bedroom. Also, the original space for the toilet is used for the storage room. On Figure 40, the area in yellow are functional changes for an extra bedroom. The bedrooms are too small (6,65m²) but almost always have been used as a polyvalent space for sleeping, studying and living.

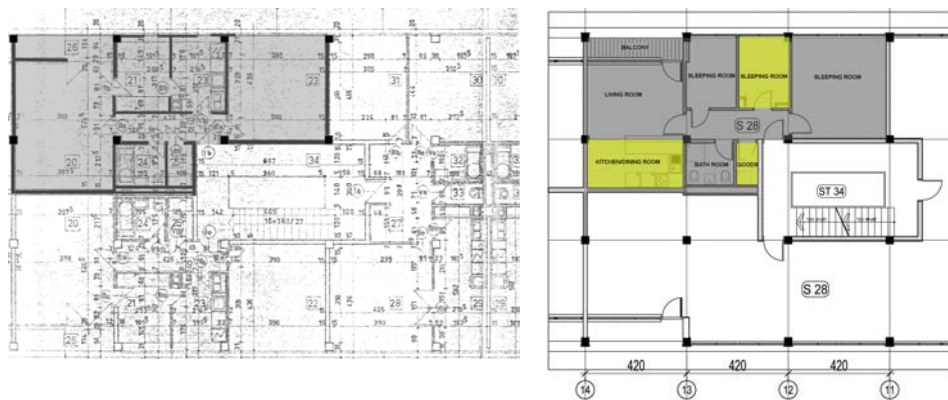

Figure 40: Meander building (Block No.21): Dwelling number 28 (one bedroom apartment; Original dwelling layout (left); functional transformations- current state (right).

Transformations on the functional and structural levels can be observed in Figure 41. As the interior partition doesn't support any loads, the dwelling space has been adapted to meet a completely new family requirements and a new functional arrangement. From a family with one child this two bedroom apartment was rearranged into a one bedroom apartment with a working room and a library for one family member. The position of the installations (main pipes and ducts) was kept in the original position. Two small rooms (6,65m²) are jointed together for the kitchen and dining room space merge together. The

partition wall between this polyvalent space and living area has been pulled down (red colored). Three previously separated functional spaces have been merged into one open space (Figure 41, right). This is a day zone with the working space and library as a new function. The working zone is separated with a mobile wall which regulates its openness.

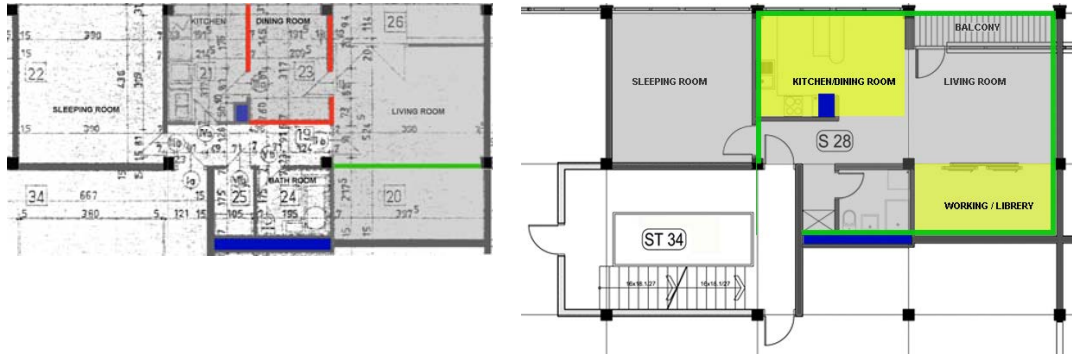

Figure 41: Dwelling number 28 (one bedroom apartment): Original dwelling layout (left); functional and structural transformations- current state (right).

In the Meander building the building installations' blocks (vertical and horizontal shafts) can change its original position. Three dwelling units are placed around vertical communication core (staircases, there is no lift). The 'area' of 3,5 s.p. x 3,0 s.p. (structural span of 4.2m) has been divided into two two-bedroom dwellings (No.28) of 65.24 m² and one (No.29) 70.89 m² (Figure 42). Two smaller dwellings have one side orientation, and dwelling No.29 has double orientations.

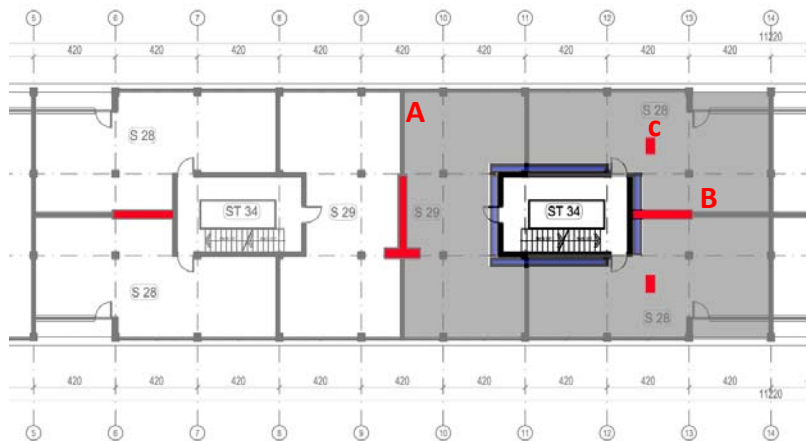

Figure 42: Installation block: Existing installations (red line); possibility of relocation of installations (blue line).

In the typical floor plan (Figure 42) the existing installation cores are marked in red. Two apartments are connected on each installation block. As the structural system is a skeleton frame, it was easy to place installations blocks anywhere in the layout. Two main blocks are placed in line with the non-bearing partition walls (A,B). Bathrooms and toilets are connected (supplied) on these cores. Vertical installation shafts (c) supply the kitchens. Focusing especially on the structural flexibility of the IMS skeleton system two advantages are underlined:

- **Horizontal installations shafts flexibility:** main structural elements (IMS columns and slabs) according to the prestressing process form a systems beams and leave the ceiling surface flat which enables the horizontal pipes and ducts to make a network for different dwelling arrangements.
- **Vertical shafts flexibility:** According to the production technology of the "cassette" slab, the 4cm thick slab can be easy removed for the installation pipes and ducts. That means that all the slab's fields could be removed with structural ribs only remaining. In the IMS construction frame the space for systems beams between slabs and column is used for distribution of the vertical heating shafts.

4.4 Open Building approach for industrialized housing

The principles of 'Open Building' proved to be a new opportunity for the refurbishment of industrialized housing in Beograd. Probably the best-known constructional principle to facilitate flexibility in housing is that of Habraken, whose theory of '*supports*' was developed in opposition to the prevailing conditions in the Dutch housing sector of the 1960s, as well as to enable his ideas of user participation. According to Habraken (1961), a building is usually divided into 'support' and 'infill' functional and technical levels. 'Supports' laid out a system in which the 'support' or 'base building' is differentiated from 'infill' or interior fit-out in housing. Therefore, it is of great importance to determine a degree of flexibility and adaptability that the individual elements ought to have in order to meet the changing user requirements. The result may be that implementation of flexibility into the 'infill' alone may not be sufficient and our focus is on the industrialized building model and the rules for structural assembly and systems order.

A support structure, as both technical device and social frame, allows the provision of dwellings which can be built and changed independently of the others (Nascimento & Habraken, 2012). The theory of 'supports' was subsequently developed into an approach that has generally become known as Open Building. The term is used to indicate a number of concepts that consider housing as a series of distinct levels of intervention or processes, "under the general precondition that the built environment is in the constant transformation and change" (Habraken & Teicher, 1998). One of the most urgent issues of Residential Open Building from the 60' was the 'built-in' flexibility of the building model for dwellings' transformations. The main issue of the Open Building approach was a design and construction of building 'support' with a special focus on the load-bearing structure as independent technical and functional level. On

Figure 43 are presented the best design for flexible load-bearing structure can be seen in.

Ecological renovation & adaptation of industrialized housing is related to spatial, technical and environmental conditions of building structure. The envelope can be changed easily according to a simple connection with the load-bearing structure and its changeability is limited due to the needs of the cultural & architectural preservation value of the buildings. Different possibilities for spatial changes must be considered according to the existing building layout and building envelope from the very beginning of the

renovation design. The spatial transformations can be made according to the flexibility of the load-bearing structure (technology and design characteristics of the load-bearing system) and dependency conditions of systems and components directly related to the flats' interior space and perimeter line (interior partition walls, installation blocks, installation components, pipes, ducts, wires, cables...).

In a technical perspective it seeks ways of refurbishment where sub-systems can be installed, changed or removed by flexible and simple connections with a minimum of interface problems (Habraken, 2003). An analysis of the flexible connections between the components in the existing building models will be a base for the industrialized housing refurbishment scenarios. The transformation capacity for the replacement, modular extensions of the building, functional changes in dwellings, etc., depends on the transformation capacity and decomposition properties of the building model.

In this research, we will consider the basic principles of open building for decompositions of the industrialized housing model. Different functional/technical assembly levels, a type of connections between the building parts will be analyzed. With the building division into the primary structure (load-bearing system, envelope, services) and secondary structure (interior partitions, services, equipment), the ecological renovation & adaptation design of housing could become very efficient. The very complicated technical part is the envelope and could be controlled by the designer (together with government /developer, etc) according to the actual law for preservation of modern heritage.

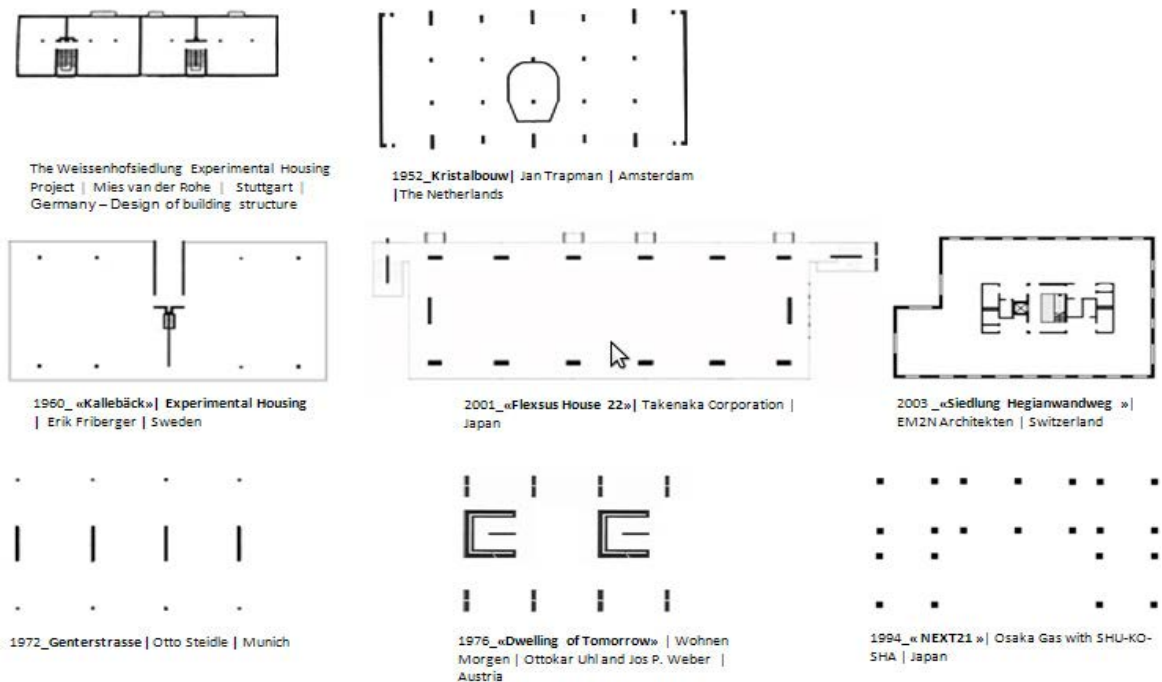

Figure 43: The best practices of Open Residential project: Flexible layout of the load-bearing structure (see: Appendix - Open Residential Building - best practices)

The load-bearing structure of the industrialized housing in Beograd was designed and built considering the flexibility issue to support transformations in the building layout. The principal 'open building' characteristics of the flexible load-bearing structure are:

- i. Building model division on the primary and secondary structure;
- ii. Long span structures with middle span area free from the load-bearing elements;
- iii. One-directional load-bearing construction, not cross-bearing;
- iv. Simple mechanical joints between structural components, subsystem and systems.

The building model and its load-bearing system layout is designed and built as a flexible and/or demountable configuration composed of industrial and prefabricated systems and components. The independency is mainly important between the technical systems that correspond to different functions.

Evolution of the system configuration from 'closed' to 'open' is represented by a transformation of a complex relational diagram and closed hierarchies between elements into an ordered path of connections between subsystems and components. Figure 44 shows the systems independency (A, B, C, D, E) and a possibility for integration of additional systems and components (Figure 44, right).

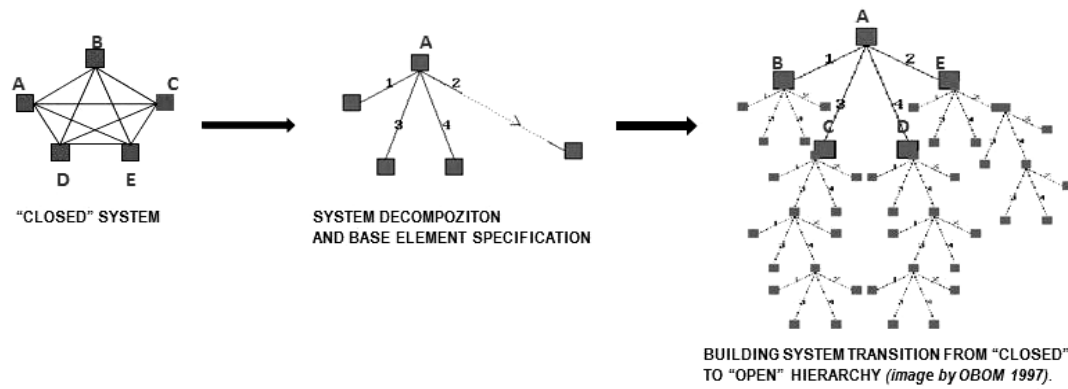

Figure 44: Closed versus open system configuration (source: OBOM, 1997): A, B, C, D, E are independent systems

5 Methodology for analysis of post-war housing in Beograd

5.1 Massive housing industrialized systems model

When we examine the composition of the complex artifacts we start from the components assembly and the connection between them. Different dependency conditions in the integrated housing model of industrialized components and subsystems have been examined using the decomposition method. The hierarchy we find depends on the criteria we apply to the decomposition of the building structure. One criteria is to consider the building according to 4 main functions (load-bearing, enclosing, partitioning and servicing). The second criterion is to consider the technical composition of the structure, its lower composition elements and the relations between them. Different types of connections have been found. The first was applied components assembly hierarchy for the technical composition of building structure. An assembly hierarchy of different building parts tells us that a unit on a higher level of the hierarchy is composed of the elements we find on the lower level (Bosma, Hoogstraten, & Vos, 2000). Analysis of the building structure as the systems model of elements and the relations between them highlights how its parts are put together (what parts and type of connections). Different dependency conditions in the building structure will be established from the analyzed hierarchies. A possible solutions may be developed by means of disassembly actions of the independent parts to upgrade housing for more transformation capacity and energy efficiency in the future.

5.1.1 Main principle of building structure configuration

In the post-war period of housing construction the constructors started to design structures based on the load-bearing system and envelope system together with architects, to build housing according to the housing demand and the needs of a particular design. The industrialized housing design had become the design and building of more flexible housing based on primary/load-bearing structure and secondary structure for building envelope. The load-bearing and envelope system were technically independent which supported the parallel assembly during the construction process (industrialized parapets could be assembled while the primary construction of the upper floors was under construction (Figure 45)).

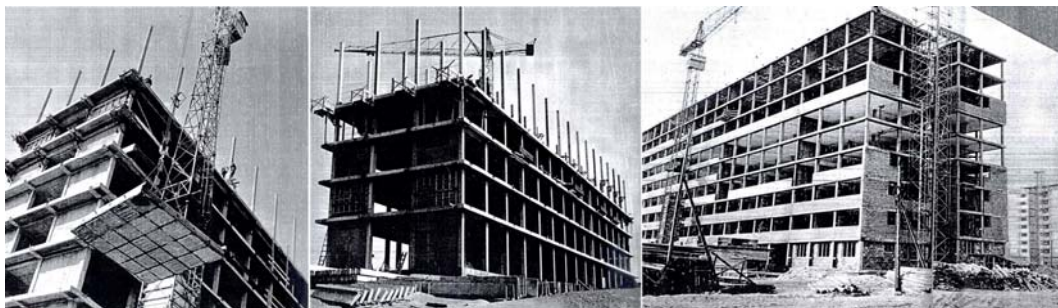

Figure 45: The IMS skeleton assembly process: Corridor building in Block No.2

The transition from the traditional construction to the industrialized building technology underlined a new era for the systems assembling according to the main building functions. Different technologies started to be developed for the load-bearing system and envelope. In the further development of the technology of prefabrication, the systems production was divided into the elements of primary construction and those of secondary construction or façades which made things easier in the coordination between the building structure and architectural design.

Further development of the housing industry was defined with a full prefabrication and thus a complete industrialization of production of all elements belonging to primary and secondary structures. This kind of systematic approach has been approved by the prefabrication of the individual systems and components. All façade components (parapets, windows, cornice, claddings...) were highly prefabricated in the factory and assembled on site. The most significant was the Industrialized, Precast, Skeleton (IMS) system with the catalogue of components for the complete building. A column-slab joints in the IMS system on Figure 46 show a standard floor slab to the left and cantilever to the right where steel tendons are visible and already post-tensioned awaiting the casting of concrete for system girders. This load-bearing system has been fulfilled with complementary components and systems in different ways (not necessary from the catalogue of the IMS components).

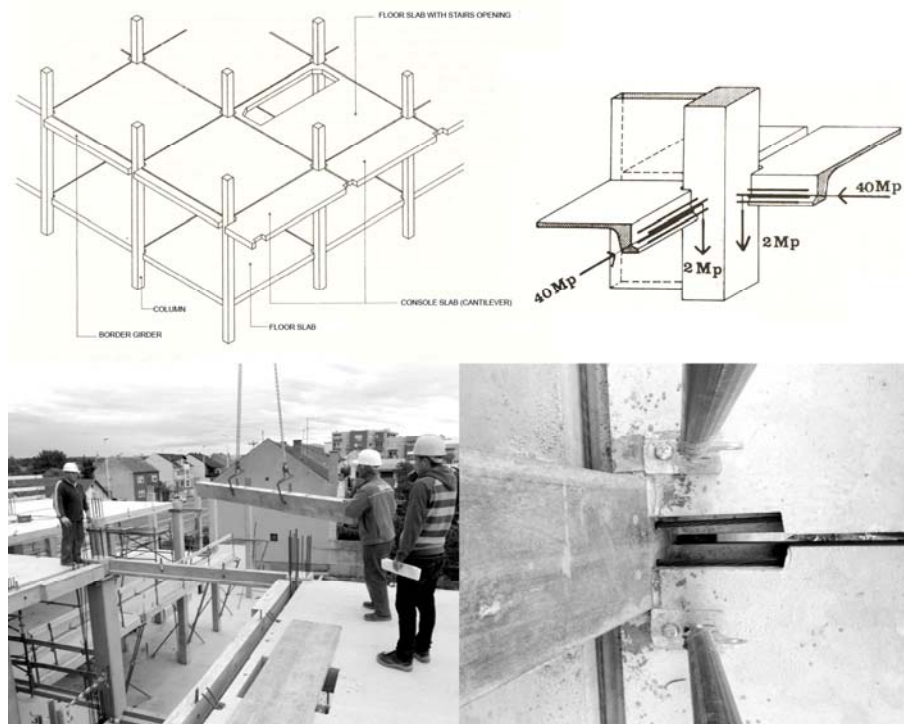

Figure 46: The IMS system axonometric of load-bearing components: concrete column, pre-stressed slabs, corner slab, edge rib¹⁴ (Petrović & Milovanović, 2012)).

¹⁴ Petrovic, G., Milovanovic N. Pilot-Building as part of revitalization of IMS Building Technology in Osijek, Scientific Conference: Planning, Design, Construction and Building Renewal - iNDiS 2012, Novi Sad, 28-30 November, 2012.

• **Building assembly according to independent technical levels**

The building structure based on the systematization of industrial components and subsystems according to independent functional and technical levels is considered flexible. Two main aspects for the components systematization are independence and exchangeability of elements (Durmisevic & Brouwer, 2006). Each technical level (all components and subsystems) has a function and a theoretical life span that dictates its need for alteration or transformation. The more often a component (subsystem, system) has to be replaced, the more accessible it ought to be (Roger Bruno Richard, 2006). Independent systems for the components systematization are established according to the principal housing functions: load-bearing, servicing, enclosing, interior partitioning and equipment.

Every function in the systems building has a corresponding technical level where different components and subsystems make connections. Independent levels were applied for industrialized housing in Beograd to separate building systems that have a different service life (Figure 47). The building components that have a longer life span (bearing components) are first to be assembled in the system configurations. Technical building levels and conditions for the systems and components connections have a direct influence on the building transformation capacity.

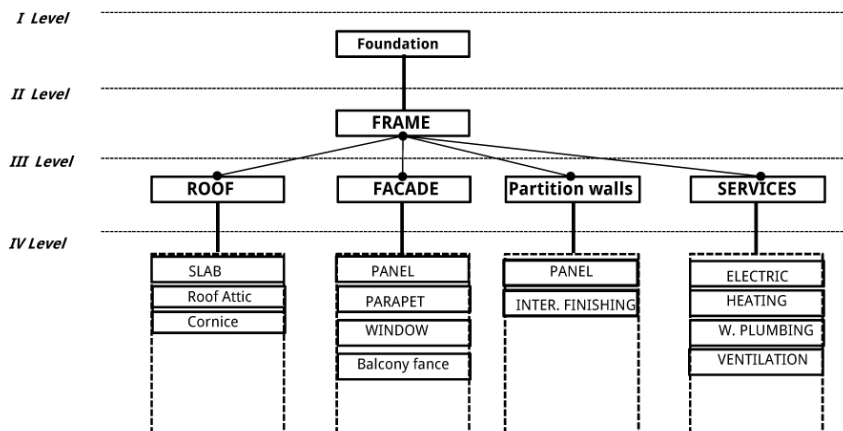

Figure 47: Systematization of the building parts according to independent technical and functional levels

The theory of levels is the base for the industrialized buildings that distinguish parts with the different life cycles. The life circle of function-system relationships set becomes shorter because of the rapid functional changes and static configuration set. Independent building levels support systematization of industrialized components and systems according to different functions. Components with a shorter life should change more rapidly and the configuration should be assembled to allow easy access for the fast changing components to be repaired or replaced. The components that perform the same function are assembled into the assembly groups. Each assembly group is based on the demountable dry-joints between the components.

- **Main principles of flexible configuration for industrialized housing**

The configuration design defines a position, dimensions, composition and connections of systems and components. Main principles of the design are:

- Flexible distribution of the construction elements in the building layout to allow a number of different distributions for the dwellings.
- The load-bearing structure is an integrated model of prefabricated systems and components assembled into independent technical levels.
- Some connections between components and systems are based on simple (mechanical) joints.
- Possibility to change the surface of the floor plan, either by additional construction or by changes in the boundaries of units out of the structure limits.
- The adaptability of structural configuration could be achieved by disassembly and reconfiguration of more independent systems.
- The connections between removable parts and load-bearing structure are based on simple joints.
- The position of services and access to them are independent.

The IMS tower building in Block No.70 with the construction span of 4.20 m provides a flexibility and spatial transformation. Figure 48 highlights the flexible behavior of the load-bearing system with the changes in the building layout and building envelope perimeter line.

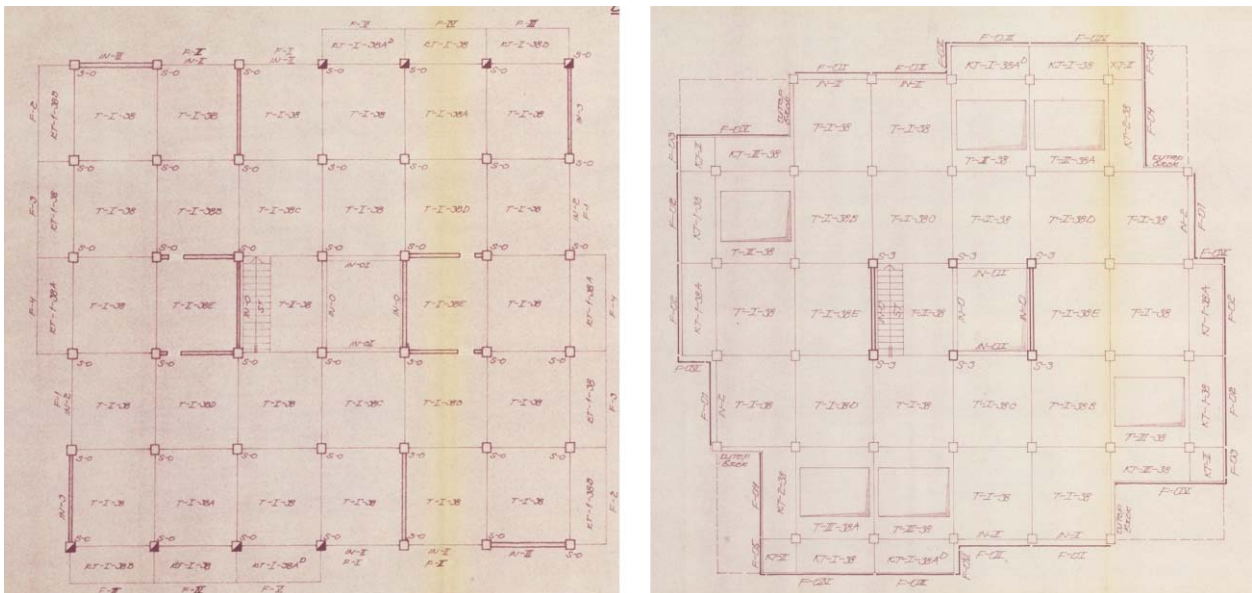

Figure 48: Different building layouts: Changes of the exterior perimeter of the building layout and building envelope, Tower building in Block No. 70 (source: Historical Archives of New Belgrade)

5.2 Graph Model - (GM)

5.2.1 Definition of the Graph Model

The 'close' system configuration which put elements that perform different functions and have different life span together in fixed connections evolved to the system configuration as a model of elements and relations. A Graph Model (GM) tool is developed to describe the industrialized housing model by elements (components, components assemblies, subsystems, systems) as a diagram of relations. Its application is twofold:

- i. Decomposition of massive structure in order to analyze the dependency conditions between prefabricated elements, viewed as a complex artifact of mixed functions and fixed connections;
- ii. Development of an integrated, flexible and demountable (IFD) systems to upgrade post-war housing building on spatial, technical and environmental level.

The interest is to look into the post-war industrialized housing as a systems building and to understand its composition and the dependences between elements. The tool is based on principles which provide the capacity to describe any relation and dependency condition of systems integration.

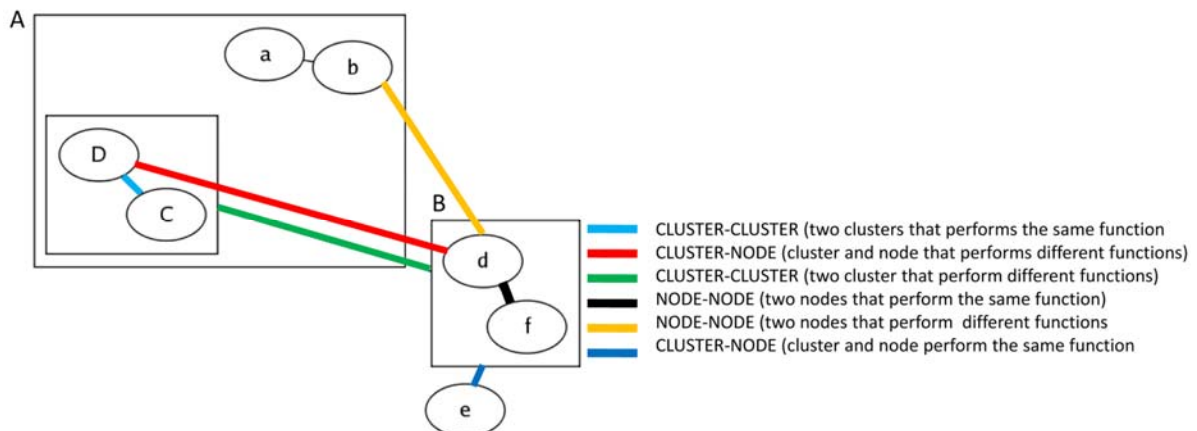

Figure 49: The Graph Model defined by Node, Edge, Cluster, and System (J. Nikolic, 2014)

Figure 49 presents the graph model and describes its main elements:

- a, b, c, d, e, f, are nodes - elements - components; is equivalent to a column of the load-bearing structure, partition wall, or water pipe.
- A, B, C, D are clusters - components assemblies (subsystems) and are equivalent to the load-bearing structure (concrete skeleton composed of beams, columns, hollow core slabs).
- Edges are different types of connections - joints between elements in the configuration. They will have a major importance in the evaluation of dependency conditions in the existing housing and

will be taken into consideration for the development of the new retrofitting strategies for housing (Jelena Nikolic, 2013b).

From the Figure 50 we can observed different types of edges:

- i. CLUSTER - CLUSTER edge - is a connection between two subsystems that perform same function or different functions (edge between façade and load-bearing system, Figure 50 left);
- ii. CLUSER - NODE edge - is a connection between subsystems and components that perform same function or different functions (edge between floor subsystem and façade panel, Figure 50 middle);
- iii. NODE - NODE edge - is a connection between components (materials) that perform same functions or different functions (edge between cantilever slab and balcony parapet component, Figure 50, right).

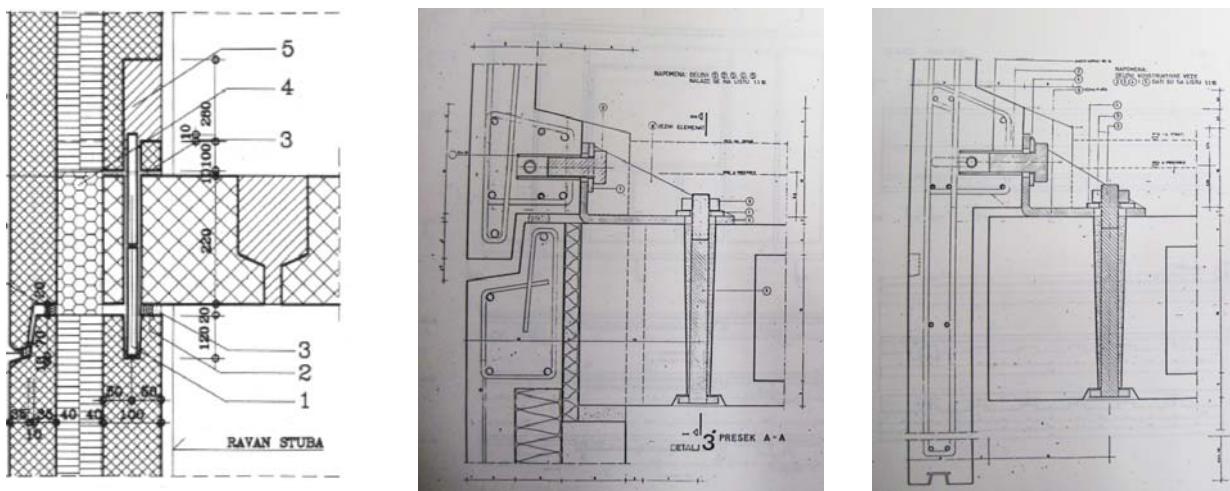

Figure 50: Different types of edges in the system configurations: cluster-cluster; cluster-node; node-node (from left to right), (IMS, 1982)

The Graph Model highlights the dependency conditions between elements in the structure and will be used for further analysis and investigation of structural problems caused by applied building method, that affect the flexibility and transformation capacity of buildings for spatial and technical adaptations.

- **Building assembly method: levels of systematization**

Steward Brand distinguished seven building layers: furniture, interior plan, services, access, structure and envelope (Brand, 1995). For example, the layers approach separates the building as a set of ‘shearing’ layers that change at different rates; the more layers are connected, the greater difficulty and cost of adaptation (Brand, 1995). Bernard and Leupen looked at dwellings in a similar way. They defined a house as a space of five different, more or less integrated layers, each with their own level of flexibility:

Scenery, Access, Servant elements, Structure and Skin. From this an adapted list of building layers is proposed:

1. Scenery - furniture, interior finishing, ceilings;
2. Interior plan - interior division of space by partition walls;
3. Access (stairs, corridors, lifts);
4. Service elements (building services, pipes, cables and involved spaces);
5. Envelope (façades, base, roof)
6. Structure (floors, columns, beams, load-bearing walls, shear walls).
- 7.

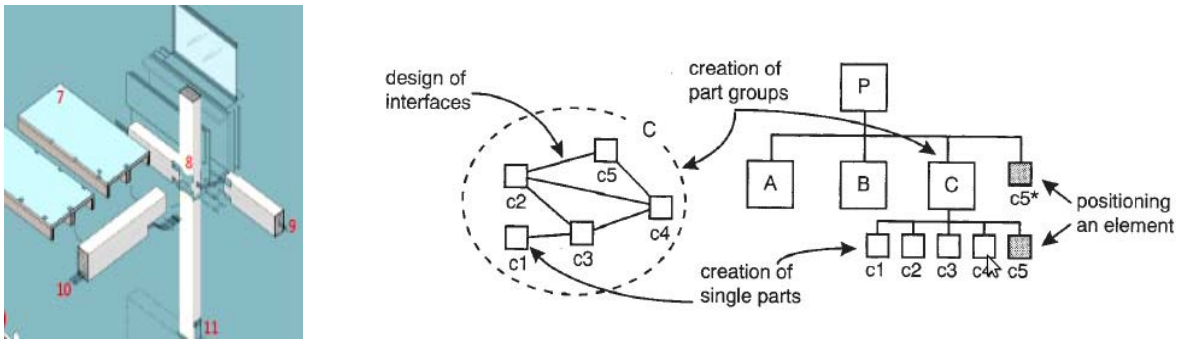

Figure 51: Systematization of building parts (Tichem, Willemse, & Storm, 1995) - right, left: Wood constructive system, (Parma, Italy, 2012)- left

The level concept is related with a technical composition of the building and attempts to balance the physical with the social understanding to achieve adaptability (John Habraken, 2008).

Figure 51 highlights the principal systematization rules for the system configuration. If P is a system configuration than A, B, C are its clusters: A-façade, B-services, C- load-bearing structure. The load-bearing cluster is composed of five independent subsystems and components (c1, c2, c3, c4, c5).

The systematization of components and subsystems into assemblies minimize the number of relations between elements within the structure and control the elements' position according to their life span. The process is based on specifying the group of elements subsystems - clusters that fulfill the same function. The type of connection between the components - nodes in one cluster is responsible for changes and improvement of the new housing performance. On Figure 51 cluster C has five nodes (c1, c2, c3, c4, c5) and the relations between them depend on their interfaces and the type of connections. Node c1 is related only with node c3 which indicates its suitability for change. Different groups of elements can be assembled independently. Every assembly group is based on demountable dry-joints. Clusters that perform the same function belong to one hierarchical level. Figure 52 shows the clusters of the IMS building (cantilever cluster and main load-bearing cluster) are in the second hierarchical level. Flexible

(simple mechanical) joints and permanent - fixed joints are visible from the graph model. Different colours define the functional properties of components and subsystems that make connections.

Which parts of the industrialized housing building are flexible - how and where and to which degree are the different layers separated/dependent?

5.2.2 Transformation capacity of the industrialized housing according to the graph model

A massive structure is the complex artifact of industrialized components and systems, prefabricated elements made 'in situ' and / or in factory, defined as a system configuration. According to the graph model different types of connection have been established and will be analyzed to evaluate the dependency conditions between different parts. Simple relations between nodes and clusters and detachable connections will allow disassembly of the system configuration.

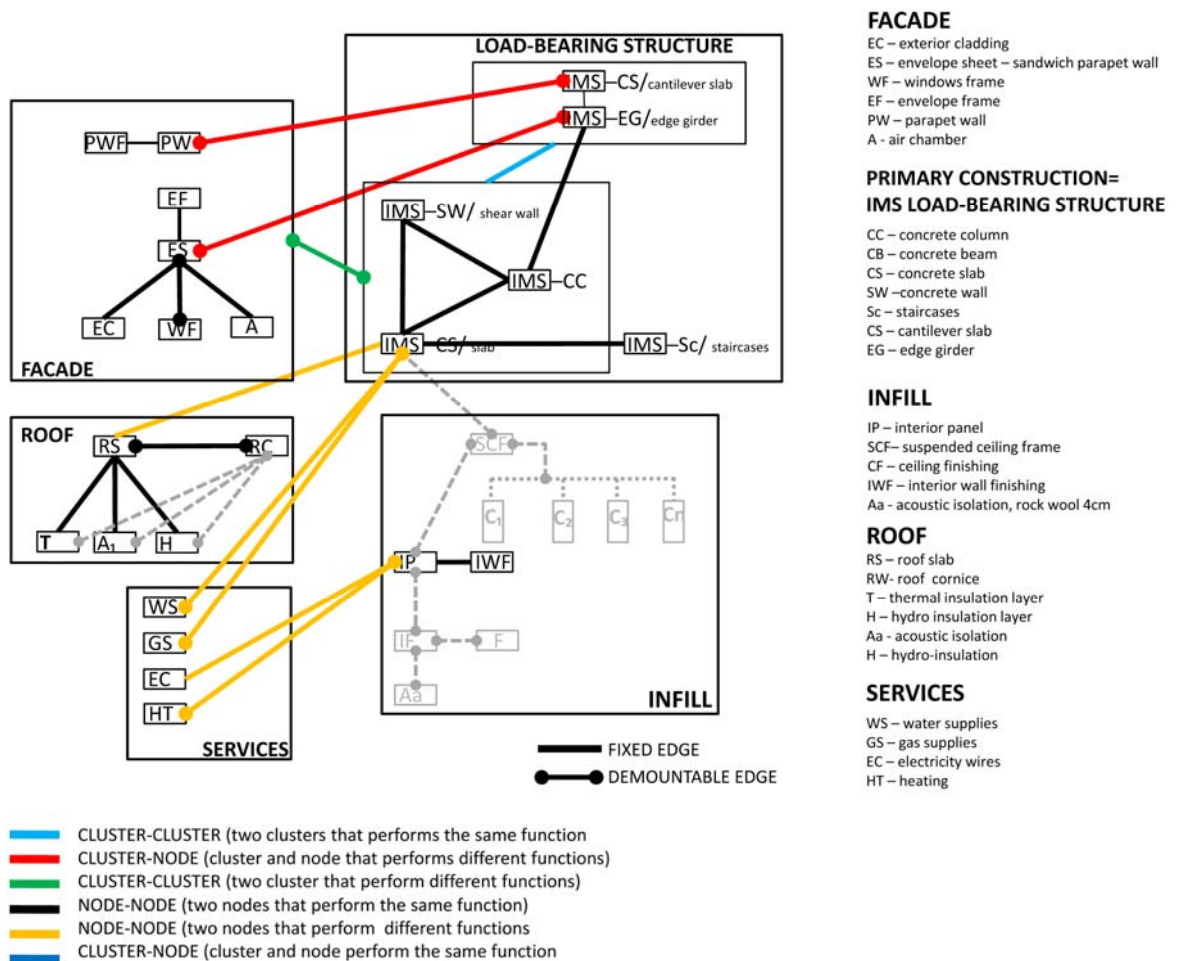

Figure 52: Graph Model of structural elements in IMS system configuration (J. Nikolic, 2014)

The first to be considered are dependency conditions of the lower composition elements and the relations between them. The second is the potential benefit of more independent building parts to be used for the planning of the refurbishment scenarios for upgrading of housing on spatial, technical and environment

level. The components assembly hierarchy will be examined. It tells us that a unit on a higher level in the hierarchy is composed of the elements we find on the lower level (Nijs, Durmisevic, & Halman, 2011).

Apparently, each fixed connection between a cluster and node (Figure 52) is a non-desired edge in the structural model configuration. The cluster belongs to a higher level in the systems hierarchy and the node, as a single element, is at the lower level that should change more rapidly. Any fixed connection between elements that are placed on different hierarchical levels is a non-desired edge. A fixed connection between two components from different levels is a problem when making changes can end up with major demolitions and waste disposal. Finally, different housing buildings will have different refurbishment scenarios according to the dependency conditions between their structural elements analyzed and established by the system configuration graph model.

5.2.3 Elaboration of the proposed method

For each of the building levels the relation with the load-bearing structure will be analyzed and indicators representing the qualities will be underlined. The following paragraphs give an example of these examinations.

The method points to a number of indicators for the **flexibility of the room-level elements**. These factors must be taken into consideration in conjunction with the scenario design requirements when refurbishment an industrialized housing in the future.

Further research will result in the various indicators and flexibility factors for industrialized housing transformation.

- **Step A:** We need to answer the question: Is the building level of a load-bearing structure entwined or interwoven with other building levels or is the load-bearing level independent of these levels, and how are the levels connected?

Indicator A1: The degree of contribution of space plan elements and variety in the dwellings layout.

- **Step B:** Evaluating if the structure layout provides sufficient space to allow the dwellings' changes.

Indicator B1: The functional free floor to ceiling height (The functional free floor to ceiling height is the part of the structural storey height which is allocated to functional use. The part allocated to services is the free service height, the part allocated to the structure: structural height)

Indicator B2: The floor span - maximum functional column-free areas.

- **Step C:** Providing sufficient bearing capacity to allow spatial changes

Evaluation of structural flexibility is important because it will increase the structure transformation capacity. This will result in longer functional life of the structure, a better match between technical

service life and functional working life. It will increase the possibilities for future adaptations and refurbishment, thus resulting in a lower waste production and a lower environmental impact of the building structure in general. The proposed evaluation method of structural flexibility can be developed into a useful tool in the integrated life cycle design and engineering.

5.3 Definition of the Building Model

Industrialized Building Model (BM) is the system configuration based on a assembly of prefabricated components and subsystems according to the independent functional and technical levels. The more often a component (subsystem) needs to be replaced, the more accessible it ought to be (Durmisevic, 2006). The following research analyzes the industrialized housing BM to evaluate its structural flexibility and transformation capacity. The independent technical levels for the components systematization are established according to the principal building functions: load-bearing, servicing, enclosing and partitioning (Figure 53).

LOAD-BEARING FRAME /	IA. FOUNDATION
	IB. LOAD-BEARING STRUCTURE
ENVELOPE /	IIA. CONTACT WITH SOIL
	IIB. VERTICAL ENCLOSING
	IIC. ROOF
INTERIOR ELEMENT/	IIIA. VERTICAL DIVISIONS
	IIIB. HORIZONTAL DIVISIONS
	IIIC. INTERIOR FINSHING OF THE DRY ZONES
	IIID. BATH, KITCHEN EQUIPAMENT
	IIIE. INTERIOR FINISHING OF THE HUMIDITY ZONES
INSTALLATIONS	IV A. WATER SUPPLY
	IV B. DRAINAGE SYSTEM
	IV C. ENVIRONMENTAL CONDITIONING
	IV D. ELECTRICITY
	IV E. HEATING
	IV F. VENTILATIONS
	IV G. COMMUNICATIONS
EQUIPAMENT	VA. INTERIOR FINSHING ANS FITTINGS
	VB. FURNITURE

Figure 53: Building model composition: division and subdivision of systems in industrialized housing building

Every function in BM has a corresponding technical level where different components and subsystems make physical connections (Figure 54). Technical building levels and conditions for the systems and components connections have a direct influence on the building transformation capacity.

'Open' prefabrication in Beograd introduced the integration of standardized components (columns, cassette slabs, staircases, parapets, windows ...) and cast in place components (shear walls, lift cores...) according to the functional and technical independence in a variety of structural configurations and combinations of construction span.

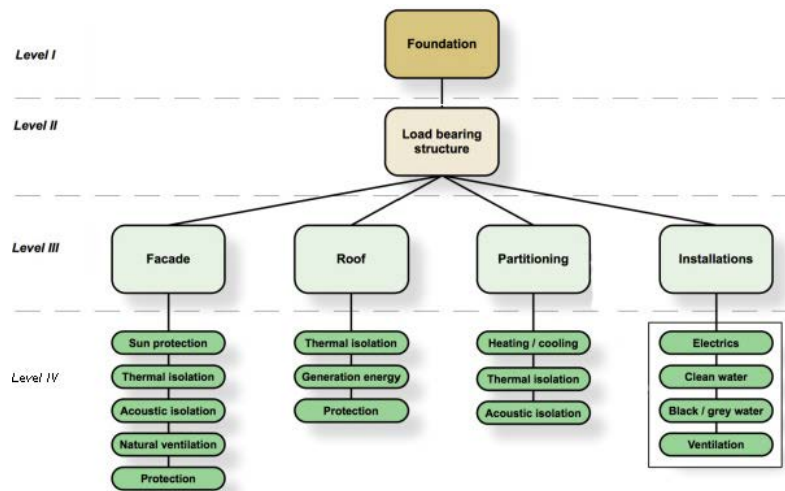

Figure 54: A systematic approach according to independent functional and technical levels for the system configuration model

The real problems of sustainable construction are in a way the elements are assembled into the lower configuration levels (level IV on the Figure 54). The long-life components are the first to be assembled independently of the fast changing lower levels (façade, interior walls). The type of joints and the interface geometry in connections play the main role to control the assembly sequences in the systems model. The simple interface geometry of elements and the demountable dry joints are the main transformation potential of industrialized housing. Simple and demountable connections in the BM will be used for planning the new refurbishment scenarios.

5.3.1 Building Model parts

- **Foundations**

All housing buildings are of different height over the basement structures. Depending on the local soil structure and condition, two types of direct foundations were used: a) the reinforced concrete strip foundation for the lower building (up to 11 floors) Figure 55; b) for worse soil - reinforced concrete slab. Deep foundation was applied for the tower building up to 23 floors with the use of concrete piles. The most common solution is a building superstructure supported on the foundation slab that is supported by a

grid of concrete contra-beams. The total foundation height from the level 0.00m varies from 1.20. to 2.00m. The basement level was created with 20-30 (40) cm of wall thickness of in-situ cast-concrete and a 30 cm slab on the ground. The basement floor is a parking area and different services' room, lately used for leaving functions. Sometimes the 27 cm thick basement floor is composed of: 5 cm outer layer of reinforced concrete, 7 cm of polystyrene heat-insulation (or air layer), usually damaged during construction, and 15 cm inner reinforced concrete wall structure. Slabs are concrete of 15 cm thickness, without any sound insulation.



Figure 55: Reinforced concrete strip foundation

- **Load-bearing system**

Considering the choice of the type of an industrial system for this study, we have chosen a prefabricated skeletal system IMS and huge panel Rad-Balency systems. The Rad-Balency large-panel system and IMS skeleton system were used to construct about 90% of the Novi Beograd industrialized housing (from 11 to 23 storey high. The IMS building technology substantially prevails with regard to the construction of the apartment buildings in an industrial way in the Novi Beograd and it is the only construction technology that remains in the application in today's construction (as load-bearing system).

- **Building envelope**

Façades in the IMS and Rad-Balency building models are constructed as "an infilling" in the load-bearing structure or "enclosing" of the load-bearing structure. An industrialized façade is composed of composite prefabricated panels. The basic material is the load-bearing part of a façade element with attached insulation and finishing coat materials. In the almost all post-war industrialized housing the building's façade is formed by parapet elements with a row of windows, with or without lightweight posts between them (usually asbestos cement sheeting and wood chipboard with EPS or mineral wool between them). The buildings from the 1960s have the finishing layer of natural concrete. Colors are rarely used for 4-

storey buildings: gray, light-blue, white-grey brick-red, for they all are gray today due to the air-pollution. Sometimes the window-frames were painted in red.

- **Multi-layer façades in the IMS and Rad-Balancy system**

The façades in the IMS and Rad- Balancy buildings are non-bearing elements. Those non-load-bearing elements are hung on or supported by edge beams or slabs (cantilever slab). Regarding their structure, these are multilayer, heterogeneous elements, made in accordance with the codes at the time of their design. The basic material is concrete with attached insulation and finishing coat materials. Different façade solutions are described in Figure 56. The most applied façade solution are *prefabricated panels* and *semi prefabricated façade*. The *semi prefabricated façade* is composed of precast RC, outer cladding and internal brickwork parapet with or without thermal insulation layer. *Semi prefabricated façade* has a total thickness of 28cm (precast concrete 8 cm; EPS 6 cm; brick 12.5 cm; mortar 1.5 cm). *Prefabricated façade* is composed of composite industrialized panels 24 cm tick composed of: internal precast RC (6cm), EPS (expanded polystyrene) 6 cm, exterior concrete (8 cm) and mortar (1.5 cm).

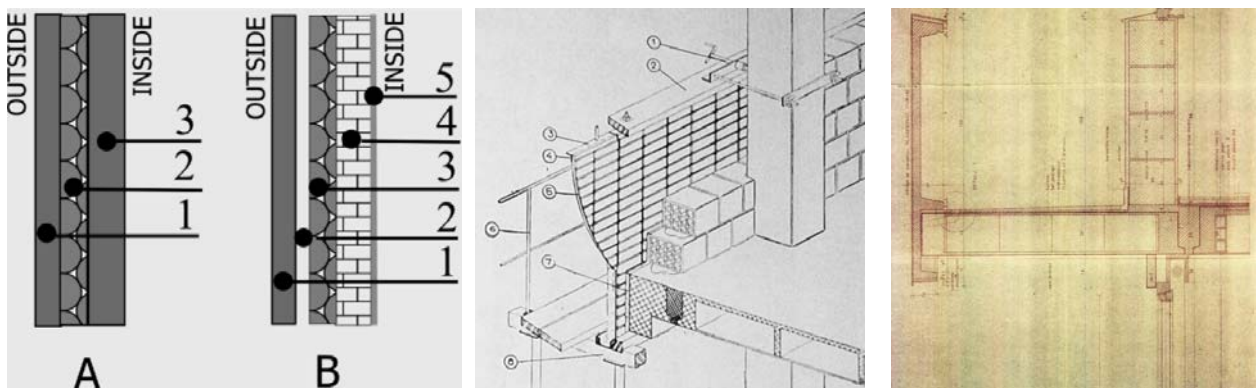

Figure 56: IMS composite panel solution and corresponding U values (Folic & Laban, 2012) **A:** Prefabricated panel: 1. concrete 6 cm; 2. EPS (expanded polystyrene) 6 cm, 3. concrete 8 cm; 4. mortar 1.5 cm; **B:** Semi-prefabricated ventilated façade: 1. precast concrete 8 cm; 2. EPS 6 cm; 3. brick 12.5 cm; 4. mortar 1.5 cm.

The classification of the façade systems was made based on the research work done in field, insight in original technical documentation and applied building technology. According to building technology façade elements are classified on:

- Prefabricated: full storey height façade panels, parapet walls, balcony fence and roof attic elements;
- Semi prefabricated: ventilated façade and façade with brick cladding and
- Traditionally built façade: ventilated façade made of light materials and façade built of bricks or other materials.

According to the components type are mentioned: i) solid wall panels - full storey-height façade element; ii) parapets; iii) light weight boards (sometimes with asbestos). The façade elements in the IMS model, in terms of form, can be divided into horizontal façade elements-parapets and vertical façade elements-panels. Further distribution of the different elements makes a difference between insulated enclosing

parapet and parapet panels for balconies and loggias. Then, we make a difference between panels without openings that complete full width of the construction span and the panels with openings for doors and windows, which can be formed by cutting into the panel.

Building system	Façade element	Structure		Building technology		Composition	
		Load-bearing	Non-load-bearing	Prefabricated	Semi-prefabricated	Single layer	Multi-layer
IMS	Façade panel full storey high		+	+			+
	Parapet wall	Supports window	+	+			+
	Balcony fence		+	+		+	
	Roof attic		+	+		+	
	Ventilated façade		+		+		+
	Façade with brick cladding		+		+		+

Figure 57: Typology and classification of the prefabricated façade elements in the IMS (Folic & Laban, 2011)

In the post-war housing building model the most common façade solution is a system of parapets and windows. The parapet elements with a row of windows were realized with or without lightweight posts between them (usually asbestos cement sheeting and wood chipboard with expanded polystyrene or mineral wool between them). Within the same building, prefabricated parapets are mostly of the same composition. In some cases, panels were supported with various clay based plates which improved the thermal bridges in connections.

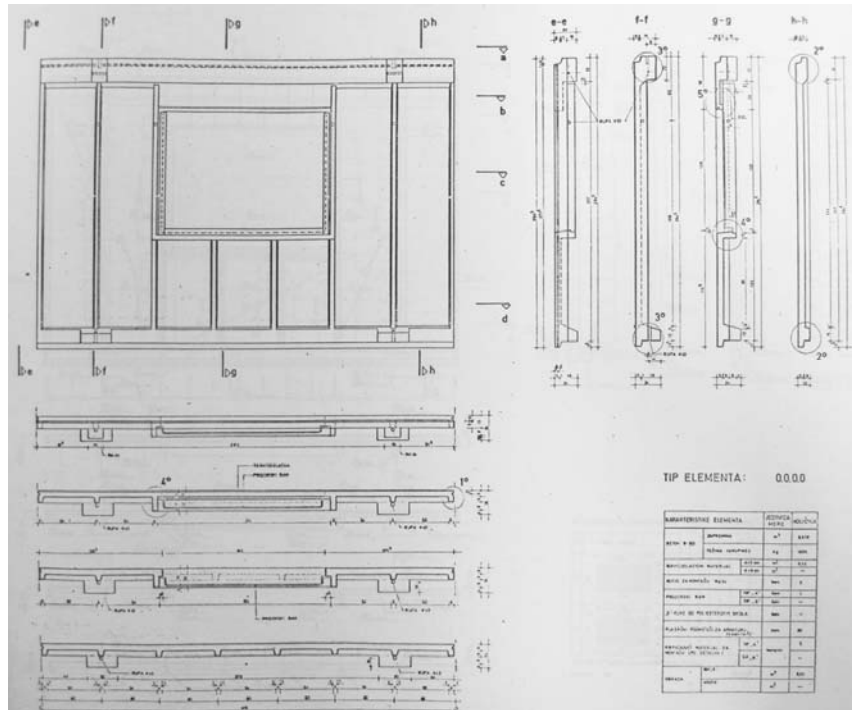

Figure 58: Full storey high façade precast element, (IMS, 1982)

A mixed enclosing systems can be found. Especially, the brick façade in the ground floor and panel cladding in the upper floors are a very common envelope solution. The prefabricated composite panels are usually found in the huge multifamily buildings up to 20 floors (Figure 58).

Prefabricated full storey height wall elements are multi-layer (Figure 58), different length panels, with or without openings. The panels are assembled between two floor structures and anchored to them. There are three basic layers composing the panel: outer concrete layer 6cm (8 cm), thermo insulation layer 6cm and internal concrete layer 8cm (10cm). Connections (edges) between IMS prefabricated panels and slab are mechanical joints (Figure 59).

Parapet wall is a self-standing multi-layer element, 100cm high, attached to the bearing structure in its lower part while the upper part usually supports windows. Composition and final appearance match façade panels (Figure 59). *Roof attic* is a variant type of *balcony fence*, 8cm thick. The fence elements were also precast concrete panels.

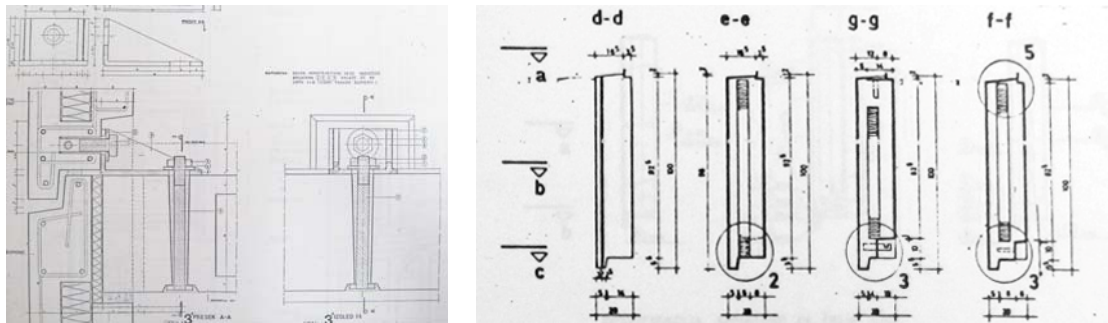

Figure 59: Multilayer parapet panel - panel-floor joint, (IMS, 1982)

Precast exterior cladding is 6cm thick, strengthened with an end/edge element and concrete or metal structural connections. Shape and dimensions of this element are based on a façade panel characteristics.

The windows with bad quality sun-shading or no sun-shading have wooden or metal frames. Especially big housing corporations tend to get rid of their wooden frames because of the higher maintenance cost. The glazing varies between single glazing (in unheated stairwells), double-glazed without gas filling and without coating. The following additional components (shutters, roller shutters (plastic or wooden) and exterior roller blinds) and solar protection are not common in Beograd post-war housing.

The building system was designed to enable the use of variant façade solutions, including different cladding and infill materials. It was also possible to produce panels with in-built window frames, as well as differently height panels, up to a full height of 260cm. The panel's width could also vary from 30cm to 480cm. The loggia of the kitchen was done in a curtain wall façade using full storey-height panel with light cladding and stone wool insulation.

- **Interior partitions**

The partition walls are made of hollow bricks, built on each floor with the cement mortar, 8 cm thick. The wall is than finished with two layers of mortar on both sides.

- **Installations**

From the early stage of the housing industrialization, building installations are treated as independent subsystems. Almost all services are available within the buildings. The central heating is provided by the district systems. Housing units from the 60s don't have central heating system, electric energy is used for heating and hot water. There are also the sewer system, running cold water, ventilations (but mostly natural), cable TV, internet and telephone network provided. Each room in the dwelling is equipped with a radiator. The whole pipe-work heating system is made of steel. Each dwelling has an access to running water and sewage system. The heating system run through the vertical shafts, that run through the openings left in the joints between edge girders or cantilever slabs. The horizontal shafts 'run' outside vertical parapet surface. Installation for electricity (IMS Building Technology) run in the space between slab and the ceiling system. The electrify cables pass through the ribs of the cassette slab in the holes of ø 30mm.

5.3.2 IMS Building Model

• Technological aspects of IMS construction system

The system configuration model is based on the systematization of structural elements into independent technical levels according to the main building functions (load-bearing, enclosing, partitioning and services). The systematization of the four main building parts in IMS structure is shown on Figure 60: IMS concrete skeleton frame; façade enclosing of windows and parapets; interior brick partitions; and services systems (heating, natural ventilation, electricity, savage system).

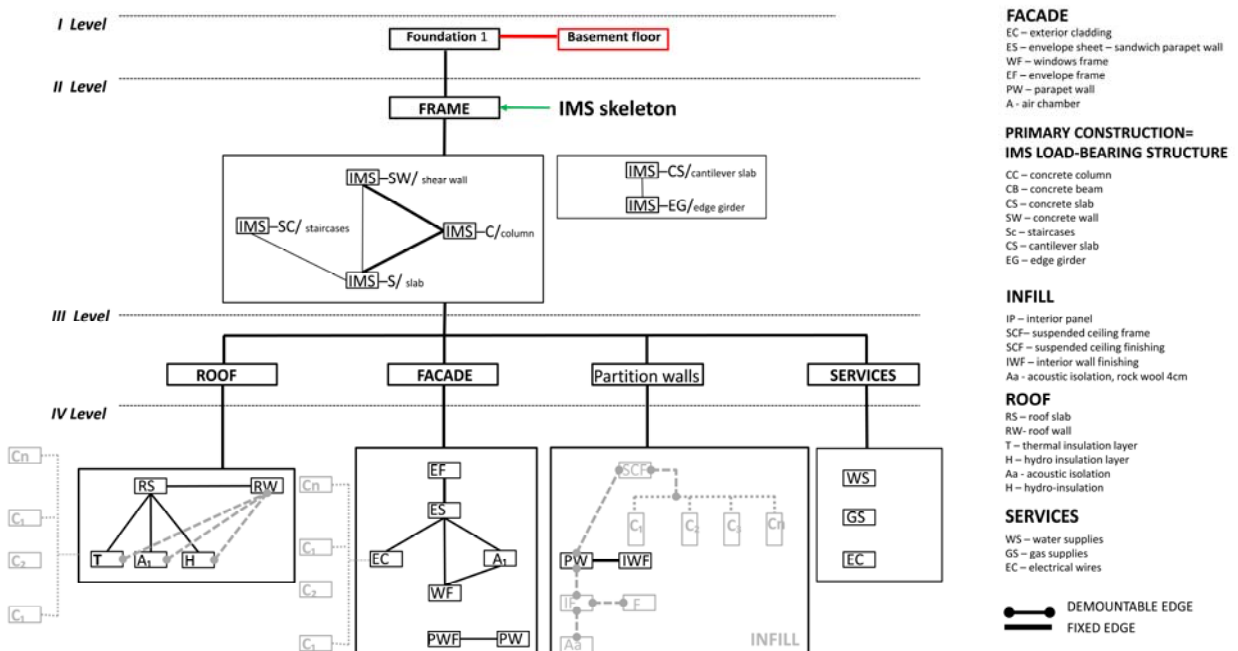

Figure 60: Systematization of components in IMS system configuration (J. Nikolic, 2014)

Figure 60 presents the systematization of elements according to the four main levels in the IMS system configuration. The building foundations and the basement floor are reinforced masonry constructions and

belong to a first hierarchical level (Level I). The IMS skeleton is on the second level which means that it is the first to be assembled. On the third level are independent systems for the façade, roof, interior partitions and services. Some of the tower buildings have the roof construction built in the traditional way. Different components, subsystems and systems of different building parts are placed on level IV. Obviously, most post-war housing buildings deal with no energy efficient systems, neither with the basic services. All grey fields are actually missing in most of the housing models. It can be observed that there are no interior systems beside the interior partitions. For this open hierarchy assembly, additional systems for the sustainable refurbishment will be integrated on level IV. This kind of a systematic approach for the building parts into the system configuration was approved after the WWII in former Yugoslavia.

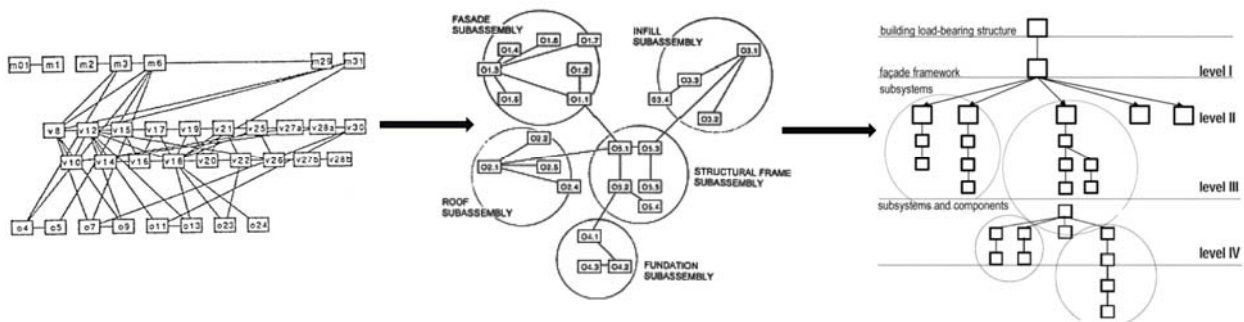

Figure 61: Systematization of industrialized components and subsystems into independent levels

Transition from a massive structure to system configurations in the Beograd post-war housing is two-folded process: i) a separation of building systems and its alteration from fixed to independent conditions; ii) a systematization of components and subsystems into independent assemblies (Figure 61).

• **Functional and architectural system's settings**

The most common structural module applied for industrialized housing was 4.20m. The width of the structural module allows its further division on two, three, four parts. One third is 140 cm and 1/4 would be 105cm. With an analysis of the different rooms content different dimensions were adopted in a range from 1/4 to 3/4 SM (structural module). The width of the dining-room is 1SM (4.20m); double bedroom from 1SM; 3/4 SM; 2/3 SM; 1/2 SM.

The most rational solutions in a structural grid are provided with a combination of 3.60 and 4.20m range. (Figure 62). The application of 3.60m grid range for the flats' depth has been rejected as not enough flexible for the dwelling organization. The range of 3.6 m is normally used in three-corridor buildings for the middle communication corridor. In the corridor buildings, the residential zone has a construction span of 4.20 and 4.80 m. The construction span of 4.80 m is applied only to the ten-storey building in Block No.21.

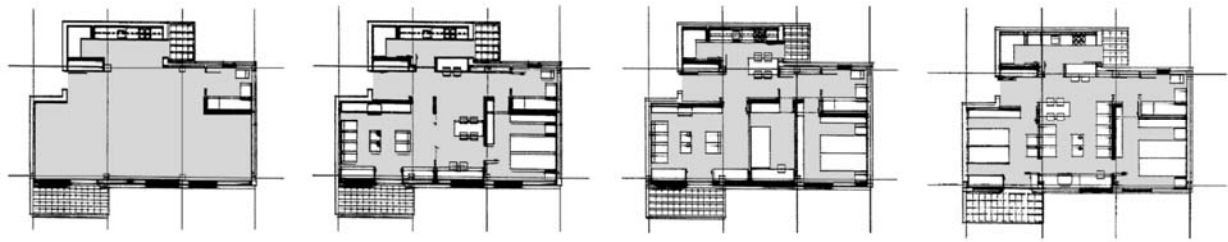

Figure 62: Functional flexibility of the dwelling layout in the IMS modular grid 4.2 x 4.2 m (Canak, 1970)

An important exit of the IMS system development are the system of mechanical joints. The mechanical bolted joint are applied for the connections between a primary construction (load-bearing system) and building envelope (Figure 63).

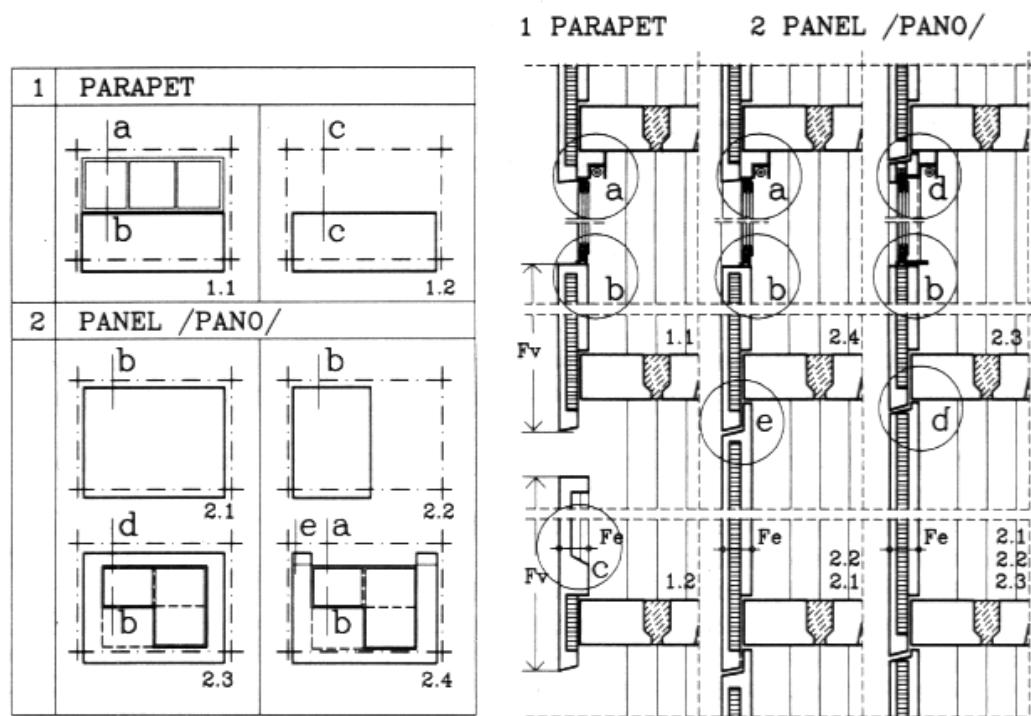

Figure 63: Schematic representation of types of façade panels and system of joints in the IMS system (IMS, 1982)

• **Construction system derived from IMS - System 50**

The System 50 is a construction system derived from the basic IMS model. The main goal was to design the units with a larger clear span. The engineer Žeželj set up structural unit of 7.20m x 7.20m, which allowed flexibility and compatibility with other subsystems (Muravljev, 2010). System 50 is adapted to be applied to single family houses and multifamily low-rise buildings (up to four stories). The structure is adaptable to all normal topography and soil and adaptive to all climates.

- **Characteristics of the System 50 BM**

A large clear construction span (7.20x7.20 m) is achieved with small number of basic structural elements.	For an apartment of 55 square metres, the average number of assembly elements is 18 (Djoković, 1985)
A basic functional unit of 50 sq. m area is possible to enlarge with units of 12.5 sq. m	<p>The growth of the structure could be possible in all directions adding new modular extensions. Main characteristics of the building model are:</p> <ul style="list-style-type: none"> • variability and flexibility of space; • flexibility of a structure in relation to other subsystems; • a possible combination of concrete with other various building materials; • high degree of planning and architectural flexibility; • separation of services and partitions from the structure; • simple prefabrication and erection technologies.
System 50 is suited for phased construction according to the main functional levels including different degrees of finishing	<ul style="list-style-type: none"> • the load-bearing structure, • structure with service core, • structure with a service core and envelope, • completely finished building
A precast and in-situ prestressed skeleton structure is formed from	<ul style="list-style-type: none"> • 7.20 x 7.20 m and 3.60x3.60 modules
Prefabricated footing strip elements	<ul style="list-style-type: none"> • various heights from 74 to 264 cm
Ceiling height	<ul style="list-style-type: none"> • 280cm
Floor slabs dimensions	<ul style="list-style-type: none"> • 358 x 358 x 24 cm. (Modular 36M x 36M)
Columns	<ul style="list-style-type: none"> • precast in one piece from the foundation to the last floor slab to the roof
Loggia elements	<ul style="list-style-type: none"> • 3.60 x 1.60 m can be attached to any of 3.60 m bays
Staircases	<ul style="list-style-type: none"> • staircase is formed as an additional unit (floor slab 3.60 x 3.60 m)
Edge beams	<ul style="list-style-type: none"> • Edge beams are L-shaped and vary in height to suit required functional requirements
Balcony elements	<ul style="list-style-type: none"> • 3.60 x 3.60 correspond to edge elements with an extended console slab and can be tied to any of the 3.60 m bays
Cornice elements	<ul style="list-style-type: none"> • 3.60 x 1.20 m
Cladding panels	<ul style="list-style-type: none"> • floor high, 3.60 m wide
Roof elements	<ul style="list-style-type: none"> • load-bearing elements are reinforced concrete ridges of 7.20 m and 3.60 m length supported by columns extensions

Table 2: Characteristic of the System 50 Building Model

The basic, 7.20 x 7.20 m unit with an area of 50 m² is formed from four 3.60 x 3.60 floor elements. Eight columns support the basic unit around the perimeter. Additional unit of 3.60 x 3.60 m with an area of 12.5 m² is formed from one floor element supported by four columns at its corners and can be attached to the basic unit in any direction by simple mechanical joints. It is possible to extend the space by adding new modules. Expansion of dwelling space can also be achieved through attached loggia with an area of 5.8 sq. m (Table 2). Gas - concrete layer is laid as a base for final floor covering of the cassette slab. A flooring base extends 4 cm over the floor slab allowing easy horizontal distribution of services.

- ***Principles of 'open' industrialization***

The development and use of System 50 is conform with the principles of *'open' industrialization* based on a balanced large-scale prefabrication of all BM components grouped into subsystems of structure: envelope, services, partitions, finishing work and equipment. The compatibility of the structure components with the components of other subsystems is ensured through dimensional coordination, techno-physical and functional criteria. This allow higher flexibility in the processes of planning, design and construction. Catalogued products based on unified criteria on dimensional coordination and performance specifications secure a high quality of planning, design and construction (planning grid - 1M, structural grid - 36M and 72 M).

System 50 support flexibility and adaptability in housing:

- Within a dwelling, through the varying number of rooms and combinations of basic and additional space;
- Within the building, through an adding or partitioning of dwellings at the same level and vertical combining of dwelling;
- In the form of exterior flexibility to subsequent adding of the functional units and staircases in cases of phased construction;
- Through reconstruction and adaptation work carried out during the exploitation period in order to meet requirements of the direct user due to changes in the family, life-style and financial ability.

The recent application of the IMS building technology in the pilot-building in Osijek, Croatia highlights numerous important technical improvements of the system that include:

- Innovations of the joints and the interface geometry of the elements in connections;
- Innovation of the assembly process and equipment: the cross-section of the side of the mould and element is simplified in terms of geometry, production and assembly procedures;
- Production of the flexible moulds with interchangeable modular sides: some sides are fixed on the side of a steel platform, while others slide over the surface and are fixed in place using magnets

(Petrović & Milovanović, 2012). Simple and quick replacement of the sides enables the design demands for different modules (3,60x3,60, 3,60x4,20, 3,60x4,80, 3,60x5,40, 4,20x4,20)Figure 64.



Figure 64: Column-slab joint in IMS Building Technology. Top-view of the standard floor slabs to the left and cantilevers to the right (Petrović & Milovanović, 2012)

5.3.3 Building Model: Case-study analysis

The territory of Block 1 and 2 (later in block 21) was the first experimental site where the IMS building technology had been experimented for a first tower building B+14 and corridor building B+ 4(Figure 65). The IMS standardized components were applied for the complete building mode. On the Figure 65 different colors represent different functional and technical levels.

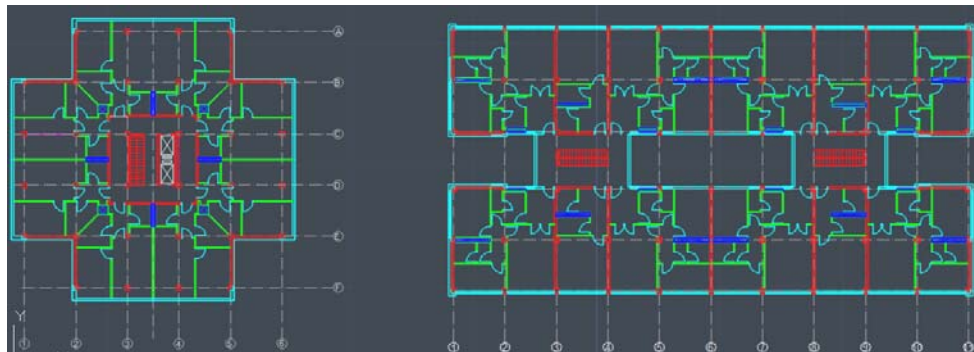

Figure 65: Block No.1: Tower and condominium buildings - Different functional and technical levels

The Building Model for the buildings in the Blocks No.1, 2 and 21 is assembled from a range of components that can be divided into five categories:

- a) Manufactured, site-installed products, systems, and components with little or no site processing (parapets, cornice, balcony fence);
- b) Off-site fabricated, site-assembled components (precast concrete elements: columns and slabs, edge girders, staircases, façade parapets);
- c) On-site processed, site-finished products (cast-in-place concrete, shear walls, concrete core for lifts);

- d) Manufactured, site-processed products (partitions walls, electrical wiring, insulation, piping, ductwork);
- e) Manufactured, site-installed (painting, sealers, glues, mastics...).

The IMS building model for tower building A in block No.1 is an industrialized prefabricated system configuration (Figure 66).

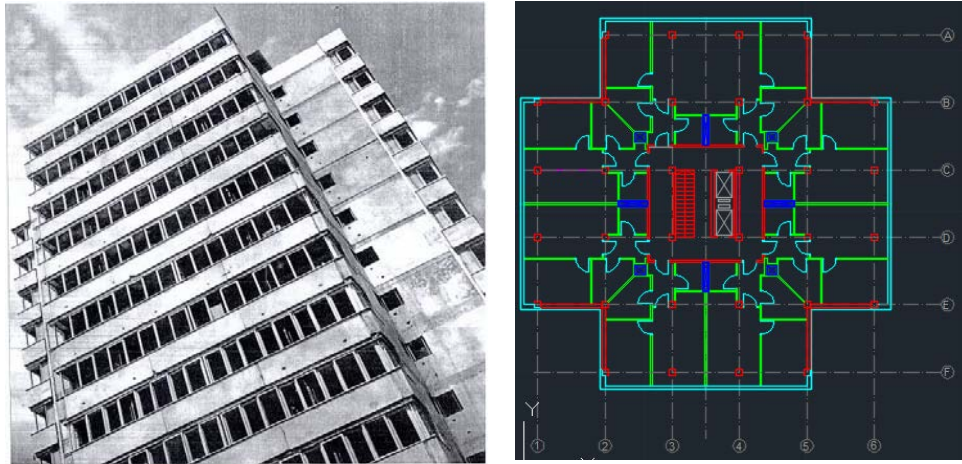

Figure 66: Block No.1, building A: The IMS Building Model (the load-bearing structure and (red); envelope (blue); interior partitions (green); installations (blue).

The IMS skeleton frame is an independent technical level on which different subsystems and components are installed in a hierarchical order: façade parapets, windows, cladding, loggias, installation block, lifts, staircases, interior partitions. This kind of systematization allows for the components like façade parapet, windows or interior partitions with a shorter life span to be upgraded independently.

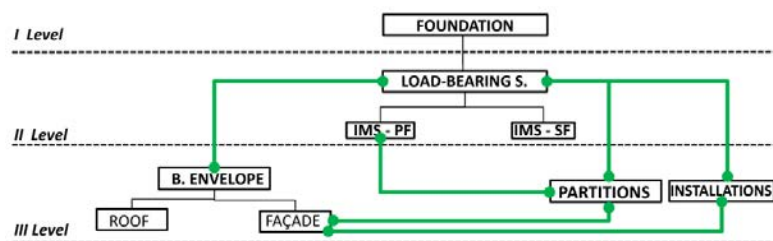

Figure 67: Systematization of the IMS Building Model according to the independent technical levels: IMS-PS (primary structure); IMS-SS (secondary structure)

Figure 67 and Figure 68 show a general systematization of the IMS post-war housing buildings into three independent hierarchical levels. On the first level is a foundation concrete slab on steel piles used to transfer the loads of a structure down through the upper weak layer of topsoil to the stronger. The load-bearing superstructure is independent of the other clusters and corresponding components on the second level. On the third level, there are envelope's subsystems and components, partition walls, installation systems for heating, electricity, water and drainage. The green edges are flexible connections mostly based on mechanical joints (façade / IMS skeleton; IMS skeleton / partitions; IMS skeleton / installations;

façade / partitions; façade / installations (Figure 67)). These edges will be used for planning a refurbishment scenario for envelope, services and functional changes of dwellings. According to the different types of connections façade cladding subsystem is more suitable for transformation. More specifically are considered the type of edge/joint between the components from different clusters.

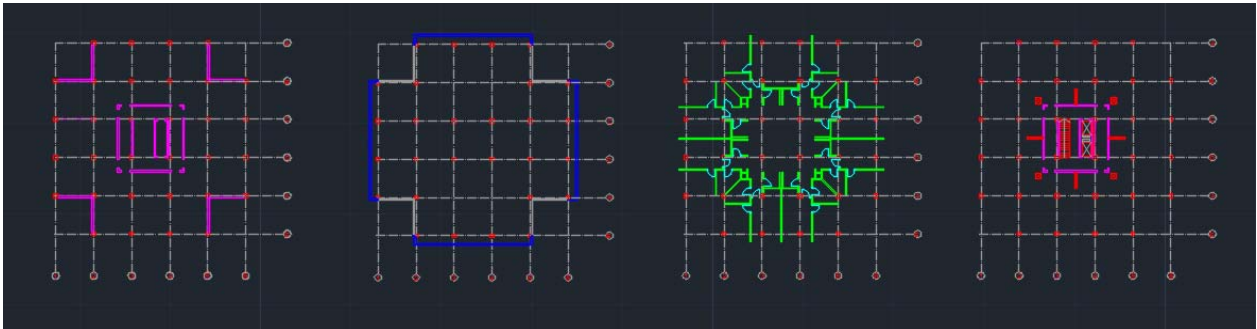

Figure 68: A building model decomposition into main functional and technical levels: load-bearing, façade, partitions and services.

The load-bearing structure is a skeleton frame with the shear walls in every corner of the building. There are two clusters of components on the load-bearing level: the primary structure - skeleton frame and the secondary structure - shear walls for the horizontal loads. Shear-walls' function is two folded: enclosing panels and bearing components. These components/nodes belong to one technical level but deal with more functions, therefore, they are technologically dependent and not suitable for transformations. A graph model of four main clusters is developed and corresponding nodes are systematized into four main technical levels (Figure 69).

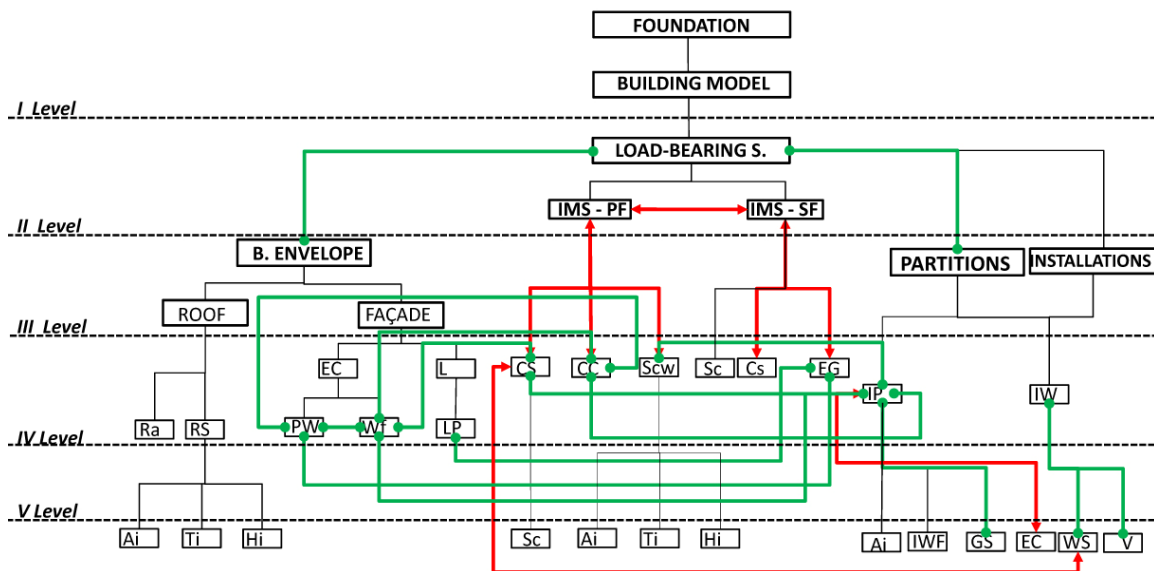

Figure 69: Graph Model for housing building in Block No.1: **PF** - primary frame (slab-column frame); **CC** – concrete column; **CS** – concrete slab; **Ssw** –shear wall; **SF** – secondary frame (cantilever structure); **Sc** – staircases; **Cs** –

cantilever slab; **EG** – edge girder, **ENVELOPE**: **EC** – exterior cladding; **ES** – envelope sheet – sandwich parapet wall; **WF** – windows frame; **PW** – parapet wall; **A** - air chamber; **BP** – balcony parapet; **L** – loggia; **INFILL**: **IP** – interior partition wall; **SCF** – suspended ceiling frame; **CF** – ceiling finishing; **IWF** – interior wall finishing; **Aa** - acoustic isolation, **ROOF**: **RS** – roof slab; **RA**- roof attic; **Ti** – thermal insulation layer; **Hi** – hydro insulation layer; **Ai** - acoustic isolation, **SERVICES**: **WS** – water supplies, pipes and ducts; **GS** – gas supplies; **EC** – electricity wires; **IW** – installation walls.

According to the graph model (Figure 69) two types of connections are detected. Red edges are dependent permanent connections between IMS components separated in the two clusters: the primary frame (columns/slab/shear walls) and secondary frame (edge girder/cantilever slab). Fixed edges IP-GS, IP-EC, IP-WS are the connections between the installations facilities (pipes and wires) embedded in the non-load-bearing partition walls and slab components (Cc).

The green edges are mostly flexible and demountable, and will be used for integration of new retrofitting components and systems. In terms of cluster-edge relations we have an easy transformable PW-EG (parapet-edge girder) edges between the components that belong to the clusters from the different levels (Figure 70). Any transformation of the PW components will not affects the EG component even if the edge girder is a component from the load-bearing cluster and a parapet belongs to the envelope cluster on the third level. Bearing in mind the level of a functional, structural and physical domain in the system configuration, new retrofitting components will be integrated according to the green edges by simple and demountable dry joints.

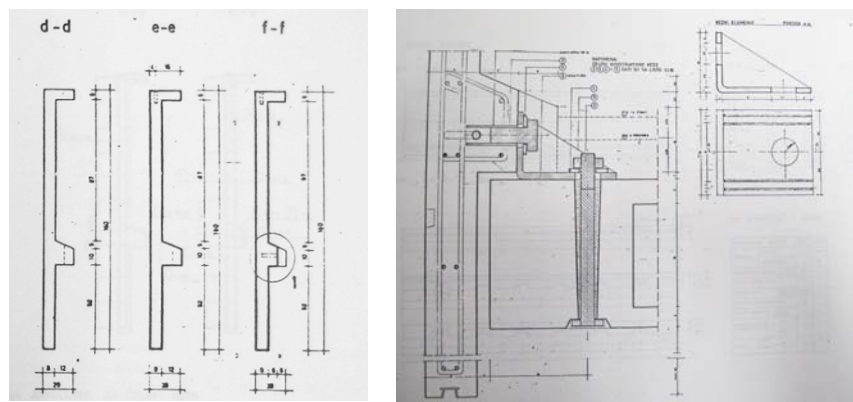

Figure 70: The connection between edge girder and loggia parapet (EG - Pw.)

The Graph model in Figure 69 correspond to the different housing typologies that have been developed by IMS building technology.

- **Sub-systems in the IMS building model**

Load-bearing structure (skeleton and floors)

The structural grid corresponds to a modular grid of 60cm horizontally and 280cm vertically with a construction span of 4.20m. The load-bearing structure is designed in a square shape 5 x 5 structural span with a 1.20m cantilever on each side. There is a building core with all vertical communications (lifts and stairs) in the middle of the building layout. Shear walls are fixed elements made of reinforced concrete 'in situ' (Figure 71). The arrangement of the shear walls in the layout imposes a significant effect on how the spaces can be configured. The horizontal edge between shear walls and IMS cassette slab (Sw-IMS-slab) are systems cables and concrete "in situ".

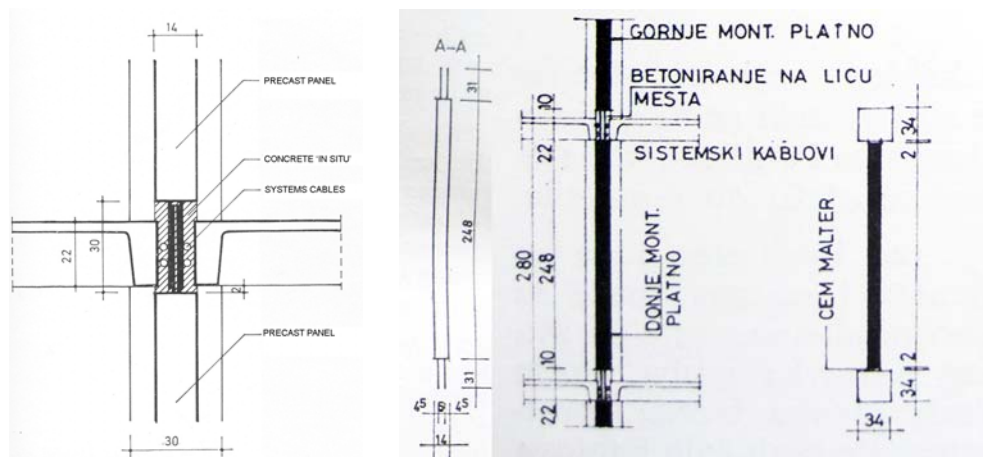

Figure 71: Shear wall connection details

In general, the more irregular the form of the unit-level shell the more difficult it is to configure the space into regularly shaped rooms in different ways. From a morphological point of view, a simple form facilitates the flexibility in the building layout, especially at the front façade where most of the rooms align against it.

- **Envelope - outer walls and roof**

The building envelope is composed of a vertical enclosing/façade and horizontal enclosing/roof clusters. Outer walls consists of 'rows' of parapets and windows (almost 70 %). The IMS columns are not in line with the façade which doesn't make the discontinuity and prevent the building from thermal bridges. The parapets are prefabricated concrete components that run between two axes. Connections between the parapet walls and floor slab are flexible edges using mechanical bolted joints. Flexibility of the connections supports the windows exchange and a retrofitting process of parapets (isolation, changing height, sun protection, etc), or a completely exchanging of façade cladding. From the graph model the most evident thermal bridges are:

- Joint between window's frame and parapet wall (PW-Wf) - edge underneath the window.

- The connection between window upper frame board and above floor slab (Wf-CS) - (edge above the window).
- **'In fill'- top flooring and partition walls**

Building layout is divided into 8 one-bedroom apartments of about 42.86 m² (Figure 72) with the same interior division. The interior partitions are non-load-bearing elements built 'in situ'. Each dwelling has a bedroom and dining room that in most cases acts as a sleeping room. The bedroom has been adapted for different family growth.

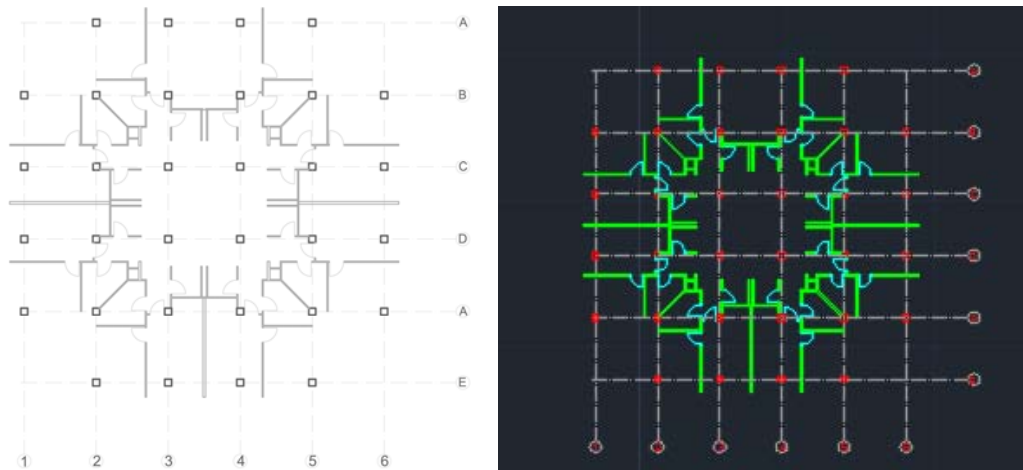

Figure 72: Interior division of the building layout - position of the partition walls(see: Appendix - Block No.2: Tower and Condominium building)

In Figure 72 the green-hatched partition walls can be treated as the removable elements. The interior division makes more dependent connections with the floor but neither with the building envelope nor with the columns. The transformations of the building layout by re-moving and changing positions of the partitions will lead the refurbishment process of dwellings to an adaptive reuse of the units in response to the changes in the lifestyle and occupancy pattern.

One of the most important functional aspects for the buildings in block no.1 is the amount of small flats and a lack of dwelling types. In time, the tenants have started to change their unit making little changes in the layout by demolishing the interior partitions, enlarging the rooms, dividing for an extra room, replacement of the old wooden-framed windows with aluminum or pvc windows and converting the loggia space into a leaving space.

- **Services (vertical through shafts, horizontally through hollow floors)**

The main vertical conduits for water, gas, sewage water, ventilation, belong to the installation blocks placed between two dwellings (Figure 73). Two adjacent apartments share one installation block. Each dwelling has two installation blocks, one for the bathroom and other for the kitchen.

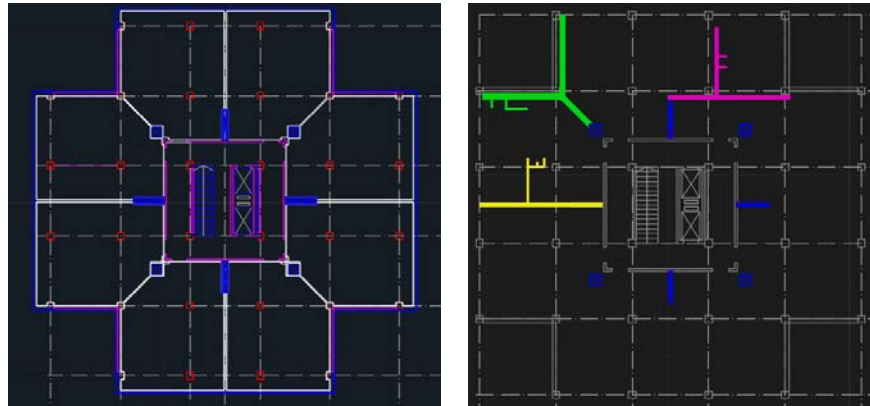

Figure 73:: Installations cores and corresponding dwelling area (left); possible transformations (right)

The installation cores can be extended along the same axes or can change the position (Figure 73, right). Once the position of the installations (installation blocks) has been chosen, surrounding free space may be organized. The partition walls of the installation blocks can be transformed as they are independent subsystems in the BM. From the main block the pipes could be dragged into the rased floor or suspended ceiling to change the positions of the bathroom and kitchen. Based on this example, changing the divisions between units, rotation or replacement of the day and night zone will be possible. The installation core with a kitchen and bathroom will become a central axis with the functions to be distributed around.

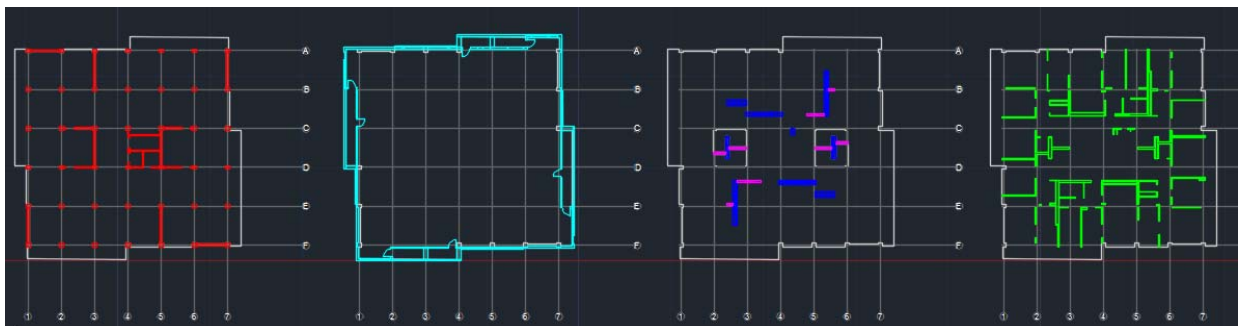

Figure 74:: A building model decomposition into main functional and technical levels: load-bearing, façade, services and partitions

The first tower building model from block No.1and 2 was further developed into a more flexible housing layout in the block No.70. Tower buildings are square (with a variable perimeter) with different height: from B+8, 11 to 14 floors. These buildings were designed and constructed in the industrial way. Different building typologies are characterized with different floor height and dwellings' layout. The IMS skeleton frame consists of columns and slabs precast concrete. The foundation and basement levels are realized from the reinforced concrete in situ. The building model clearly distinguishes four independent functional and technical levels (Figure 74).

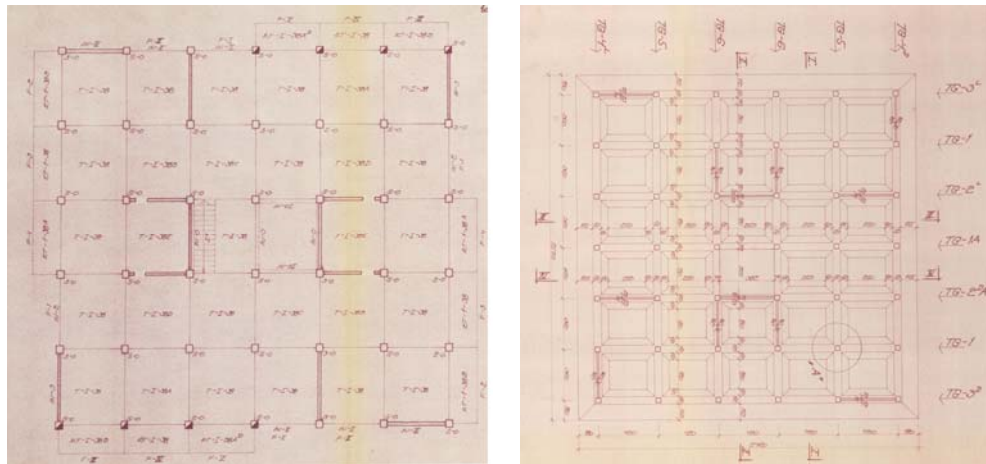

Figure 75: The load-bearing layout of tower building B+14: Typical floor plan and foundations

The IMS load-bearing structure and building foundation level are presented in Figure 75. The shear walls for the horizontal loads are prefabricated 20 cm thick components. Position of the shear walls is fixed in the building layout. IMS structural span is 3.60 m and 4,20m. We can observe a completely flexible dwelling layout and façade perimeter line in Figure 76. The façade surface runs outside or inside the last columns line, thus creating dynamics and diversity of the interior space. All the interior partitions are non-bearing components of metal studs with plaster board cover. As for the non-bearing components, their position could be anywhere in the building layout.

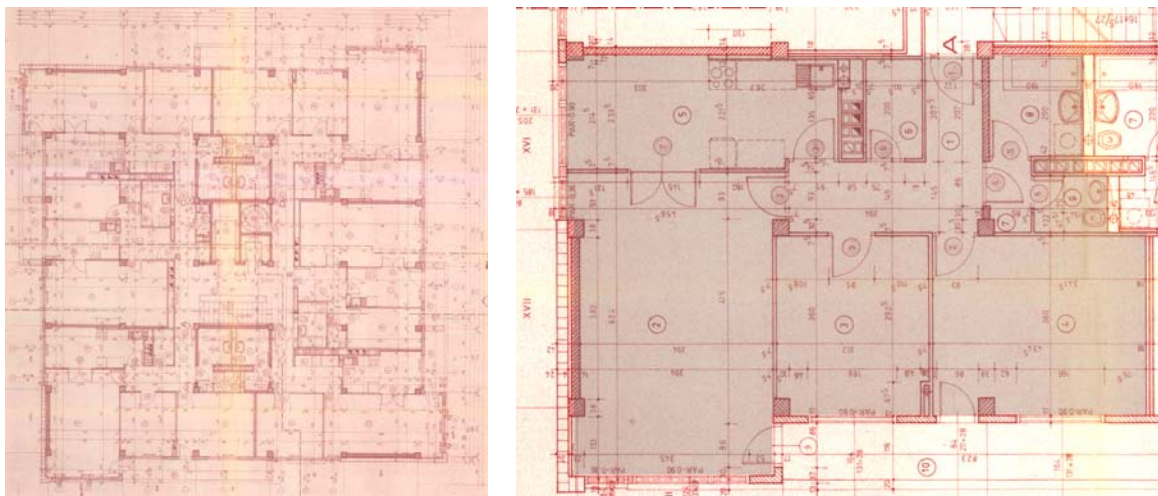

Figure 76: A typical floor plan (left); A two-bedroom dwelling unit(right)

The typical façade solution of horizontal parapets and windows was replaced with industrialized panels, with all the windows and doors preinstalled in the production line (Figure 77). A panel thickness is about 18 to 30 cm. A complete façade panel is composed of a parapet wall, window and columns between windows. All the openings were preinstalled before the panel erection. The design thickness varied

around the 20 cm. The solid façade panels are prefabricated components and work as the shear walls for horizontal loads. The façade is supported from floor to floor by semi-mechanical joints (Figure 77).

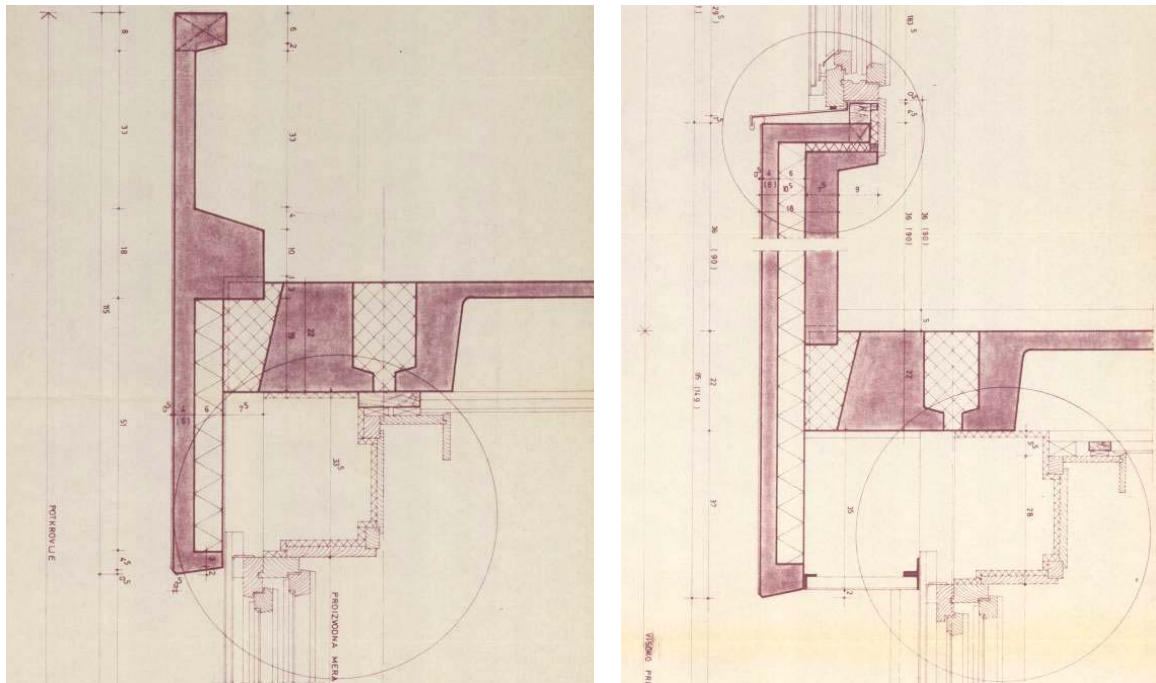

Figure 77: Façade panel section: Connections detail with a roof (cornice components-left) and floor slab-right

The building lifts' cores are prefabricated elements too. The lift components were prefabricated in a form of 'II' (two elements for one story height). The components were executed from 10 cm thick prefabricated panels. Loggia panels were fabricated in different building technologies as they didn't have contact with the outside weather conditions.

Sanitary block is an industrialized component and was installed in a coordination with the building structure. Managing the installation pipes and ducts through the holes in the cassette floor slab was very common. The IMS floor slab was easy to adapt, providing only a necessary holes for blocks connection (Figure 78). The maximum size of the holes in one cassette was 70x70 cm.

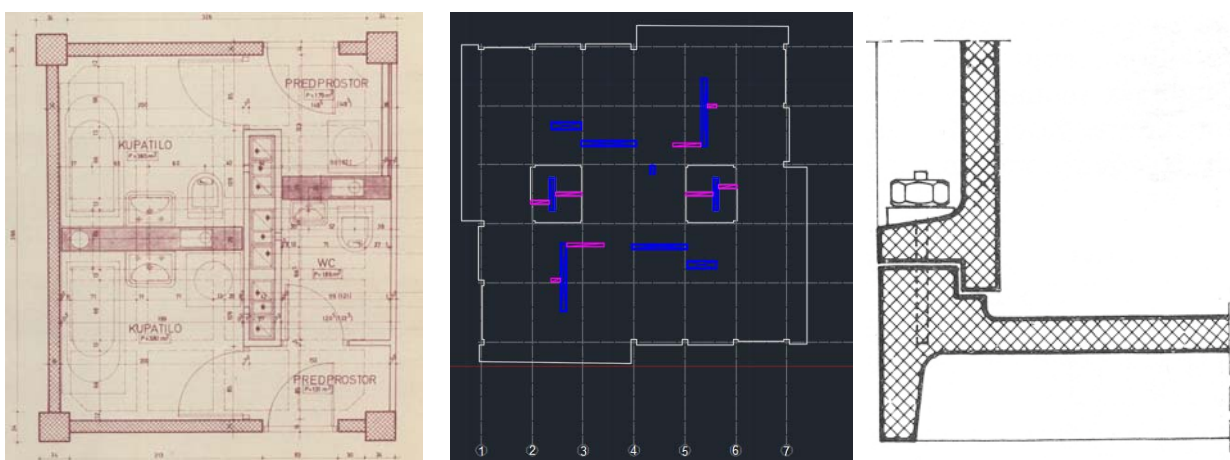

Figure 78: Installations' wall with ventilation canals specified for different flats height

In Block No. 21 was built The Meander building in 1960-1965 (see: Appendix - Block No.21 : Meander building). The building has B+4 floors + loft and total length of 980 meters with 794 apartments (Figure 79). One of the central lamellas, entrance No.4, is chosen for an analysis. The empty load-bearing 'lot' was in-filled with a set of 3 dwellings and 1 communication core. The two sets at the end of the lamella are different (two dwellings per core).

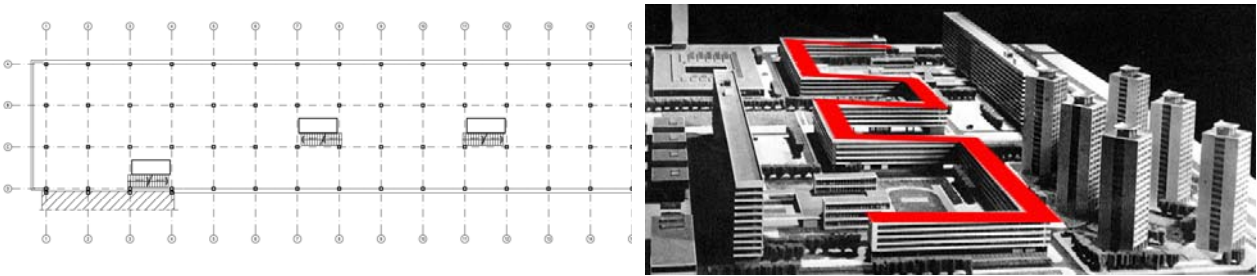

Figure 79: Building Model: Load-Bearing structure

A typical floor plan has four dwelling types, the dwelling units No. 25 and 26 are larger with a double orientation (Figure 80). The two-side orientated dwelling No. 25 is three bedroom apartment. Every room has direct access to the loggia. A dwelling No. 29 is a two bedroom apartment with a two-side orientation and without loggia. The most common are two-bedroom apartments. A dwelling's layout is organized around the access entrance - kitchen, dividing the space on the day zone and night zone. The day zone is the living room with the loggia, commonly used as a sleeping room. The night zone includes one big double bedroom. A dining room has been changed in time to be suitable for various functions (library, sleeping room, studio...)

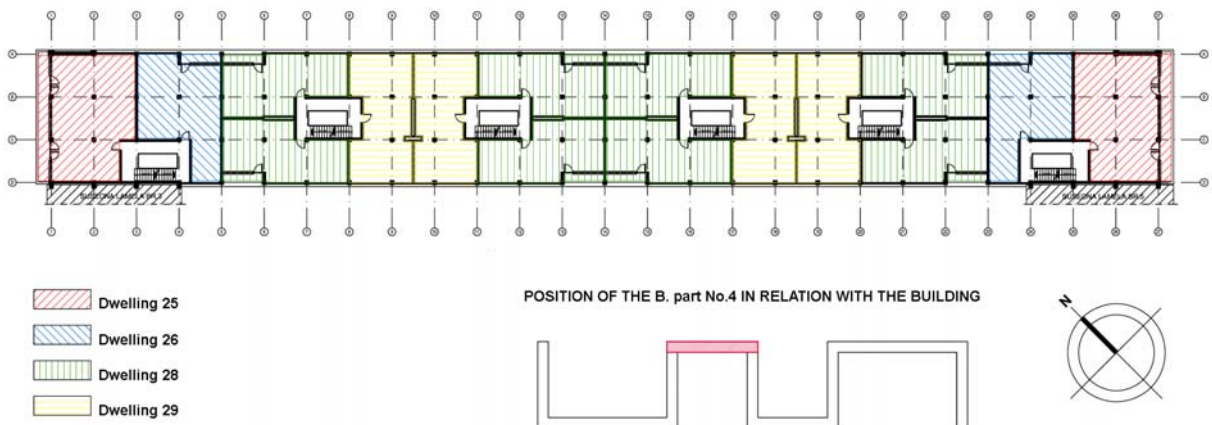

Figure 80: A typical floor plan and dwelling types(see: Appendix - Block No.21 : Meander building)

The IMS building technology was applied for a bearing system divided into four levels: load-bearing system, envelope, partitions and services. The building is built on concrete slab of the reinforced concrete 'in situ'. Load-bearing frame has 26 structural spans of 4.20 m. A total length of the structural 'lot' is 112 m and 12.6 m wide (three structural spans). The total surface of 1411 sq. m is divided into 6 sections. Every section contains one communication core with three dwellings of about 200 sq.m (dwelling area). A lack of the lifts underlines a wheelchair inaccessibility.

The vertical shell is composed of parapets and windows (Figure 81). Façade parapets and balconies are prefabricated industrialized components. Usual problems (thermal bridges, façade damages, etc) and their solutions will be approached with a building thermal refurbishment. The refurbishment of the buildings to satisfy different requirements will influence the building envelope changes. A parapet wall is a self-standing multi-layer element, 100cm high, attached to the bearing structure in its lower part, while the upper part usually supports windows. The composition and final appearance matches façade panels. In the Meander building, interior façade parapet is a traditional wall from 19 cm brick elements. The roof attic prefabricated components are a variant type of a balcony fence 8cm thick.

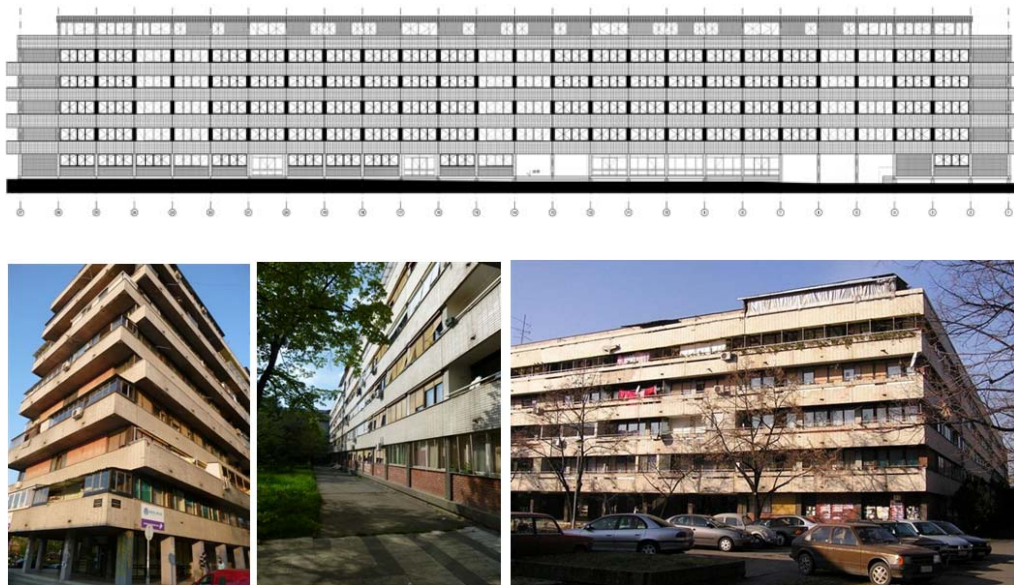

Figure 81: Rows of parapets and windows façade model (see: Appendix - Block No.21 : Meander building)

- **Technology of joints between different components**

Two types of connection in the industrialized model are dominants: fixed-moonlit connections and mechanical connections. For an upgrading of the Building Model the mechanical joints are suitable for transformations. The main flexible joints are: a) Pw-S (parapet - slab); b) W-Pw (window - parapet wall); c) W-C (window - column).

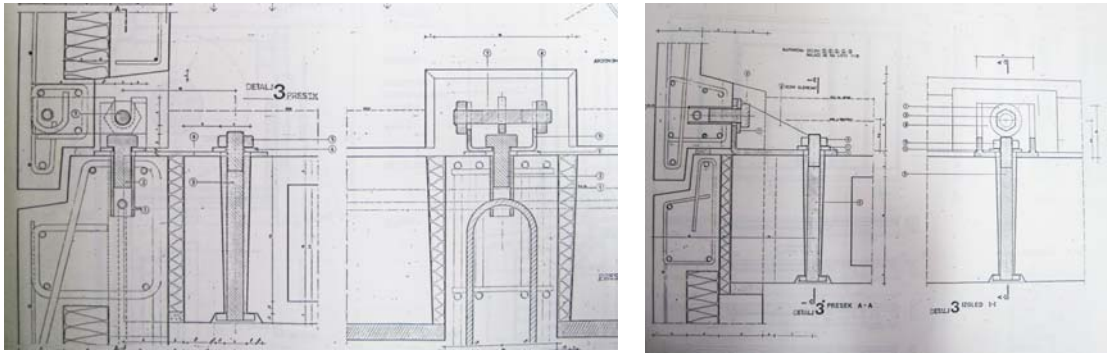

Figure 82: Pw - S connections: Mechanical joint of the IMS façade panel and slab (left); Detail of joints PW-EG (parapet wall – edge girder) - right;

Loggias parapets are the IMS catalog components. The connection between the parapet and cantilever slab is demountable joint by L profile (Figure 82, right).

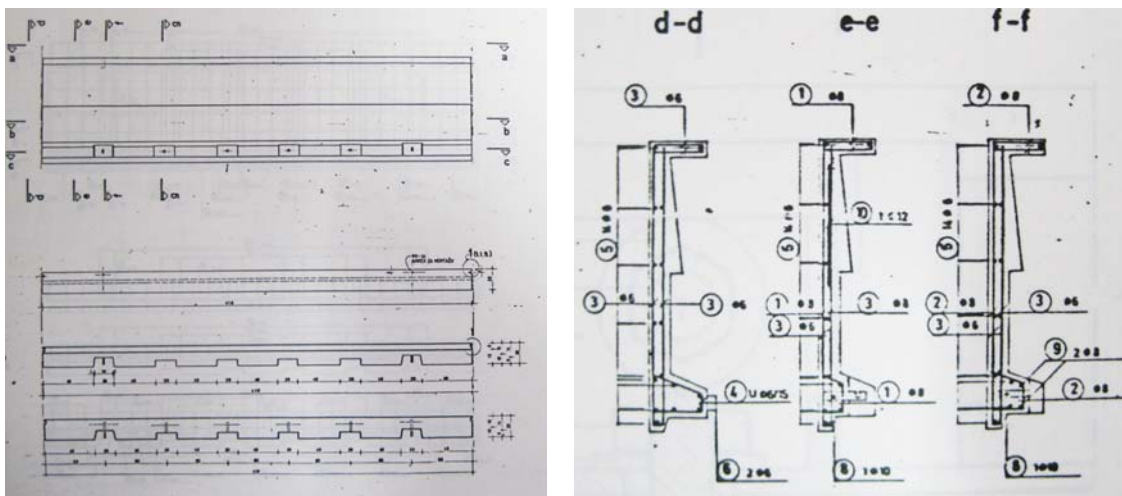

Figure 83: Industrialized prefabricated IMS component for parapet wall

Another example is the Building B9 in Block No.21. Building B9 is one of the first housing projects built in the IMS system. Total prefabrication of all structural elements and clear separation of primary and secondary structure is applied to the Building Model. Every second floor has a cantilever slab for the continuous balconies that run all along the entire lamella. The section details of the façade are available in Figure 84.

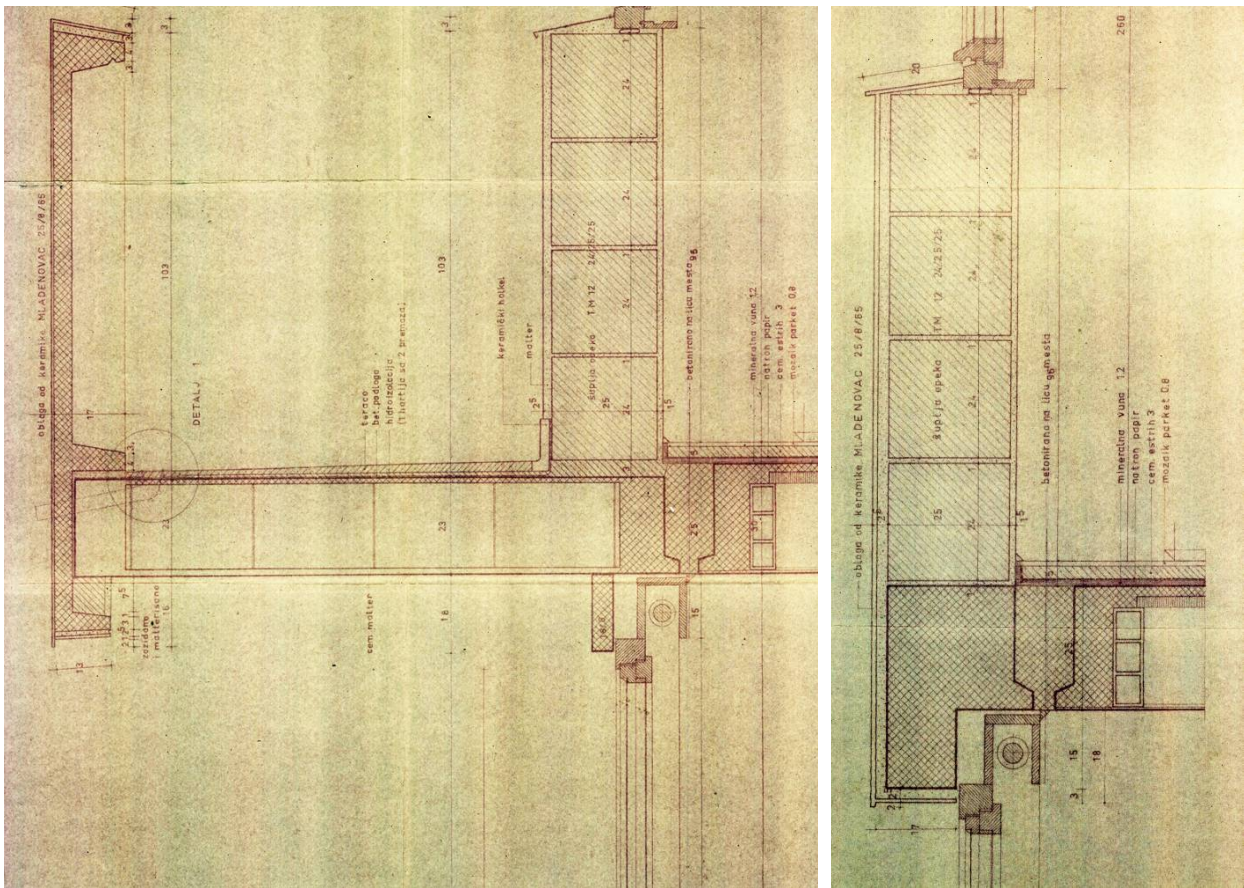

Figure 84: Building B9 - Composite façade structure- fixed and mechanical joints

Façade is a mixed system of: the masonry brick parapet from the inside and industrialized parapet components from the outside. The balcony fence (with a maximum height of 110cm) is a self-standing precast concrete element, attached to the bearing structure in its lower part. Different joint technologies are applied: the traditional joints were applied between the brick parapet wall and IMS edge girder; the mechanical joints are applied to the industrialized parapets and cantilever IMS slab (Figure 84).

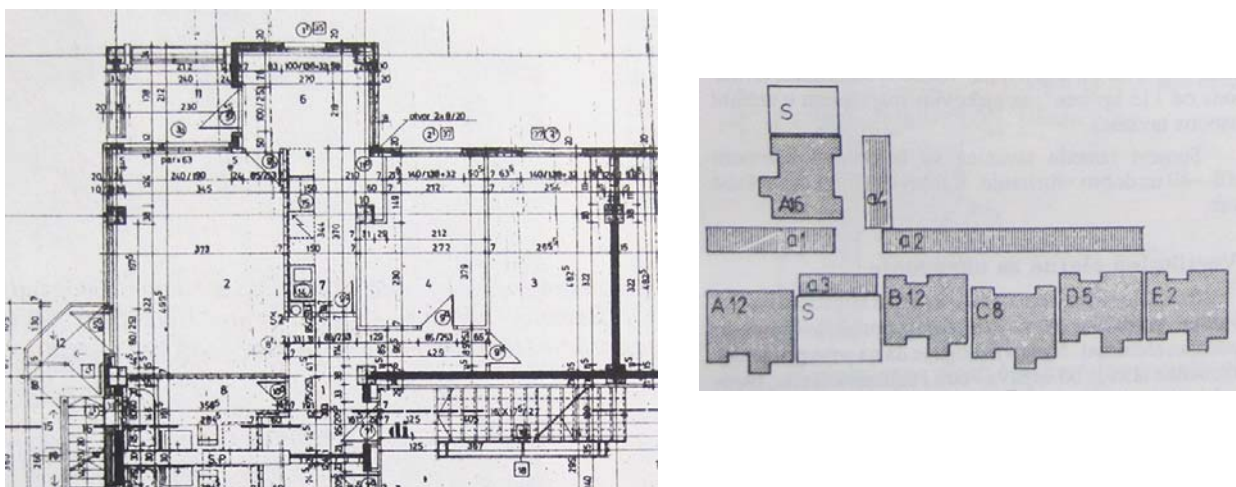

Figure 85: Block No.63 - Building No.06 B2(see:Appendix - Block No.63 : Building No.06 B2)

Further development of the IMS industrialized building model was a tall tower building up to 23 storey. The building 06 B2 from the block No.63 is shown on Figure 85. The IMS construction building technology is applied to the load-bearing system with the construction span of 3.60 m x 5.40 m.

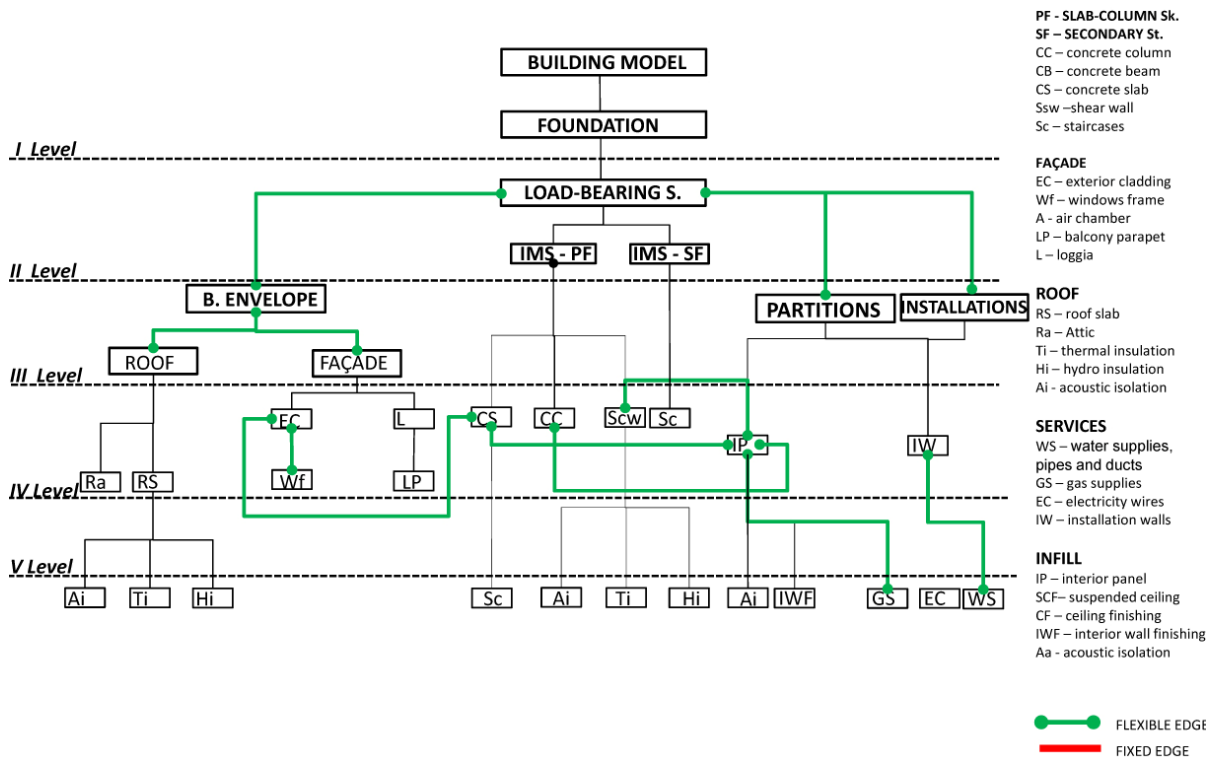

Figure 86: Graph Model for the building No. 06B2 in Block 63

The building complex consists of different height volumes (from 5 up to 20 storey). The prefabricated and industrialized components were applied as a completely finished product (cassette slabs are fabricated with the ceilings, façade panels are prefabricated with the windows). Different systems for foundations had been applied according to the different buildings' height. Object A-16 - 20 stories (Figure 85) is based on "Franky" pilots $\phi 500$, long 12-13 m. Object A-12 i B-12 - 16 stories are based on a continuous slab with inverted beams, and objects C-8 (12 stories) , D-5(9 stories), E-2 (5 stories) are based on the strip foundations. Lamellas A16 and A-12 are towers, B-12, C-8, D-5, E-2 are row buildings.

The entire building has 348 flats and 20.088 m² neto surface. A column of 38/38 cm section is used in the object A-16 but in lower buildings a column of 34/34 cm is adopted. The joint between the slab and column is prestressd with 4 cables $\phi 7$. Joints between slabs are in concrete MB-40. The building model consists of 5 independent parts: IMS skeleton, shear walls, roof construction, façade enclosing panels and interior partitions. The shear walls for horizontal loads are reinforced concrete elements cast on site up to 12 floor, and then prefabricated (up to 20 storey).

We observe that the major subsystems are independent in the graph model. A building model composed of industrialized and prefabricated components and flexible joints (façade panels and load-bearing system; partitions and load-bearing system, partitions and installations; installation / load-bearing system)

may be refurbished on different levels of its composition. The interior partition can exchange its position for functional changes and spatial upgrading. The space around the sanitary blocks is completely flexible.

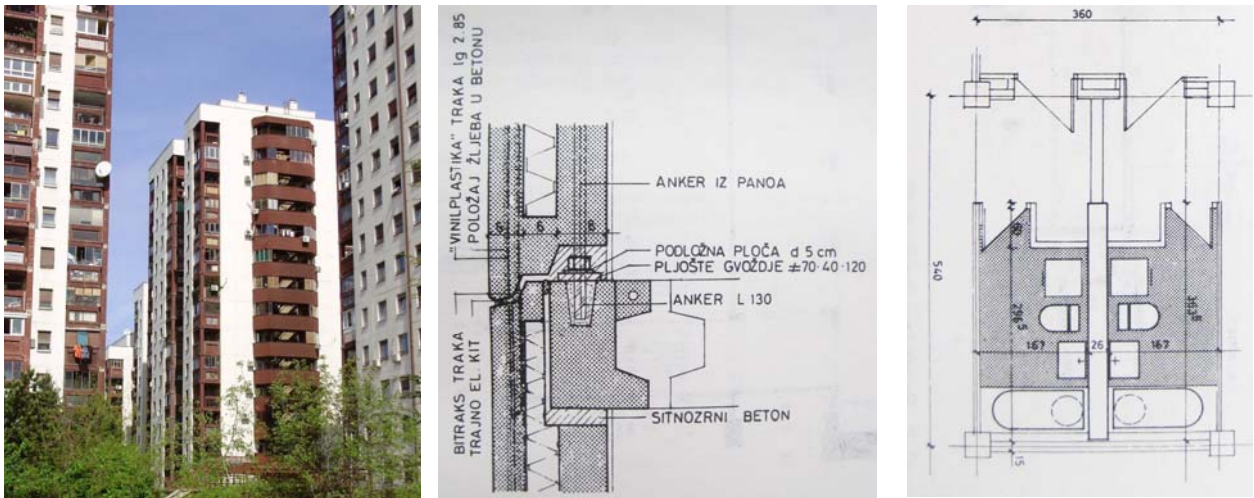

Figure 87: Prefabricated panel cladding and joint with floor slab

The main aim of this project was to apply the maximum of industrialized catalog components to the building model and to design a flexible dwelling layout. Sanitary panels and blocks are installed (one for two units) Figure 87. Façade panels are composite components of 20 cm thickness (outside concrete layer 6.0 cm; insulation 6.0 cm; inside concrete 8.0 cm).

Atrium buildings in Block No.45 were built in 1965. Housing objects (B+2; B+4) are mixed structures. The structure of the buildings is the “book-shelf”-framework of site cast concrete floor structure and transverse inner walls and gable walls (Figure 88). An integrated building model consists of: huge panel bearing system (Trudbenik) - transversal wall span 3.74 m, and cast-in-situ reinforced concrete slabs; vertical enclosing - parapets and windows from the north and balconies on the south façade.

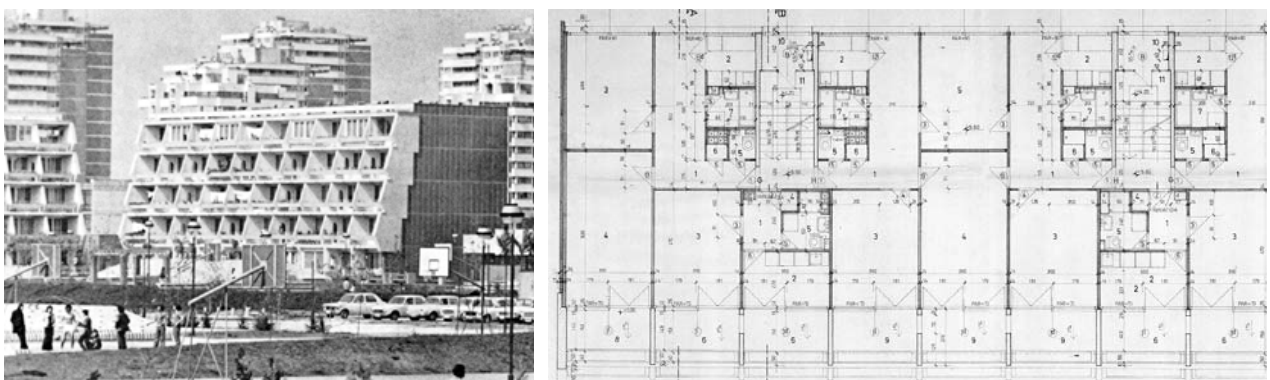

Figure 88: Atrium building: Building process in progress and finished building model (see: Appendix - Block No.45 : Semi-atrium building)

Balconies are annexed on the south side. The balconies represent an extension of the primary structure completed as a prefabricated and industrialized subsystem (Figure 89). We can observe a diversity in the

façade obtained by changing a depth of the balconies in Figure 89. The balconies can be transformed independently of other building parts.

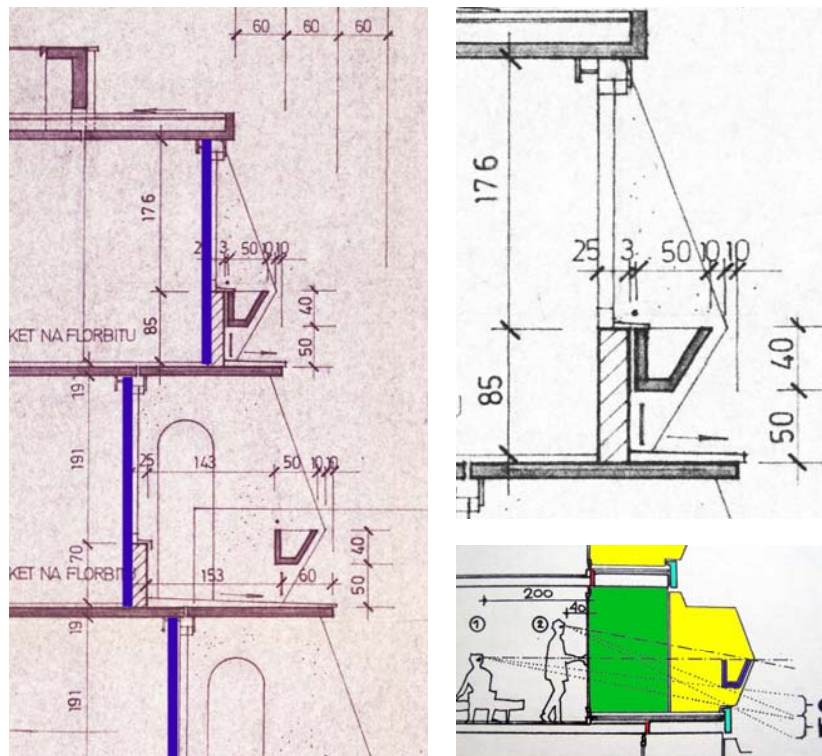

Figure 89: Balcony structure: Range of applied components (colored elements are industrialized components)

Huge panel construction system had been applied for housing in the blocks 61- 64. Buildings are designed in a cascade line of six lamellas. The buildings are long about 160m with the variations in height: 2 to 20 floors. The first lamella with five floors is the lowest part of the building, next lamella has four stories more, up to the highest one with 20 floors.

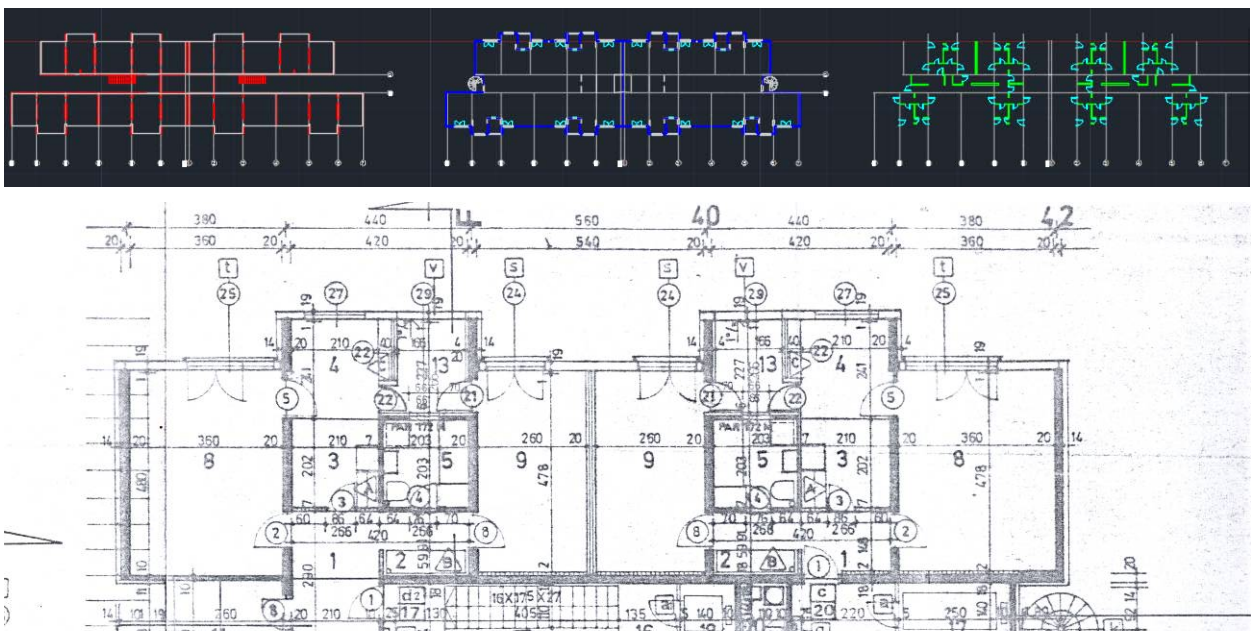

Figure 90: Block No.62, Building A1 (06/62): Independent building levels

Most rigid part of the building model is the primary construction, continuous concrete slabs 14 cm thick supported by vertical bearing panels 20 cm thick. Construction span between cross bearing walls varies from 3,60 m, 4,20 m, 4,80 m and 5,40 m. The constant variations of construction span had been adapted to the different dwelling's functions (Figure 90). The construction height floor-to-floor is 2,80 cm, basement is 3,15 and 2,45 m. The central corridor is used for the horizontal and vertical communication, and common services. Around each stairs are four dwellings. We can conclude that the huge panel building models had been designed as a multiplication of dwellings' design.



Figure 91: New Belgrade-City of Housing: Block No. 64 (foto by Goran Jovanovic)

The conventional huge panel system from cast-in-situ RC concrete has been replaced with the prefabricated huge panel Rad-Balency system.

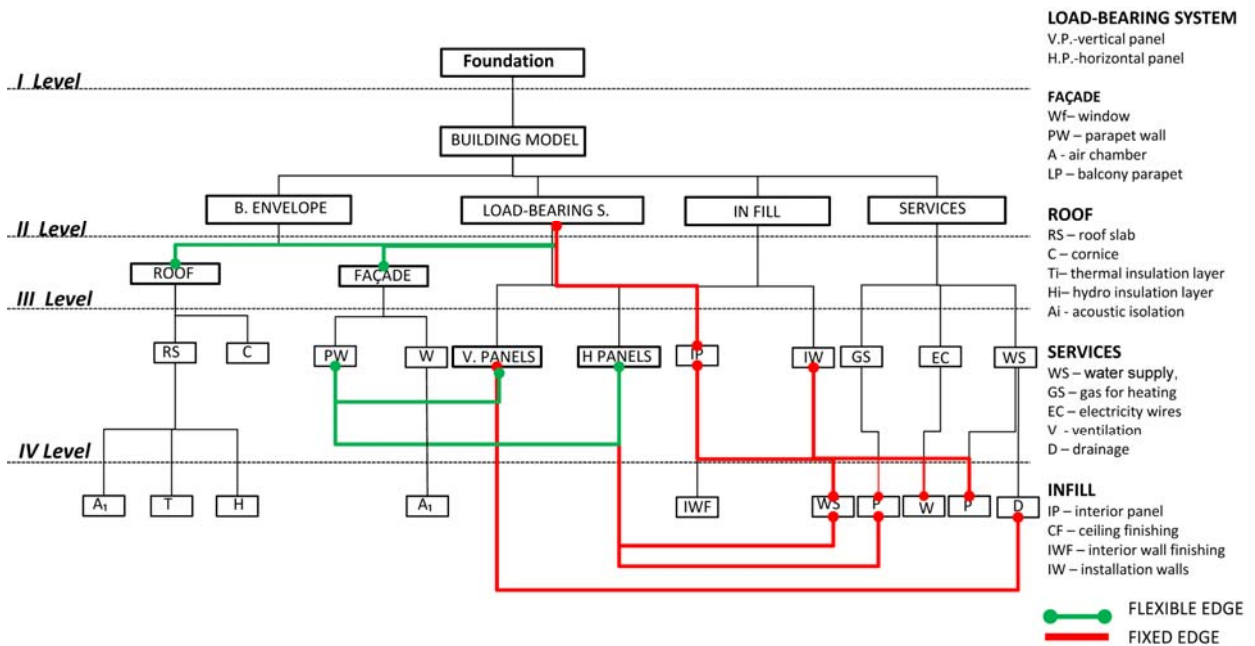

Figure 92: Graph Model - Rad-Balency system

The Rad-Balency huge panel system had been applied for buildings in the blocks No. 61-64. The building model is composed of five main systems assemblies: load-bearing structure, envelope, partitions, services' blocks and equipment with installations for each unit. For the load-bearing structure are applied transversal walls 14 cm tick. The façade is non-bearing system composed of the multilayer prefabricated panel: concrete 19,0 cm, thermal isolation 4,0 cm and exterior concrete layer 8,0 cm.

Graph model (Figure 92) highlights the dependency conditions in Rad-Balency building model. The (Pw - H.PANEL) edge is bolted joint by steel plates and L profile. Future refurbishment scenarios will be planned on the envelope level (façade and roof). The interior partitions are load-bearing components and the refurbishment at dwelling level is difficult to realize.

We can observe that the major subsystems are dependent. A building model composed of industrialized and prefabricated components and fixed joints (partitions and load-bearing system, partitions and installations; installation / load-bearing system) could be retrofitted at the envelope level. Different energy-efficient measures will be planned for envelope refurbishment scenario.

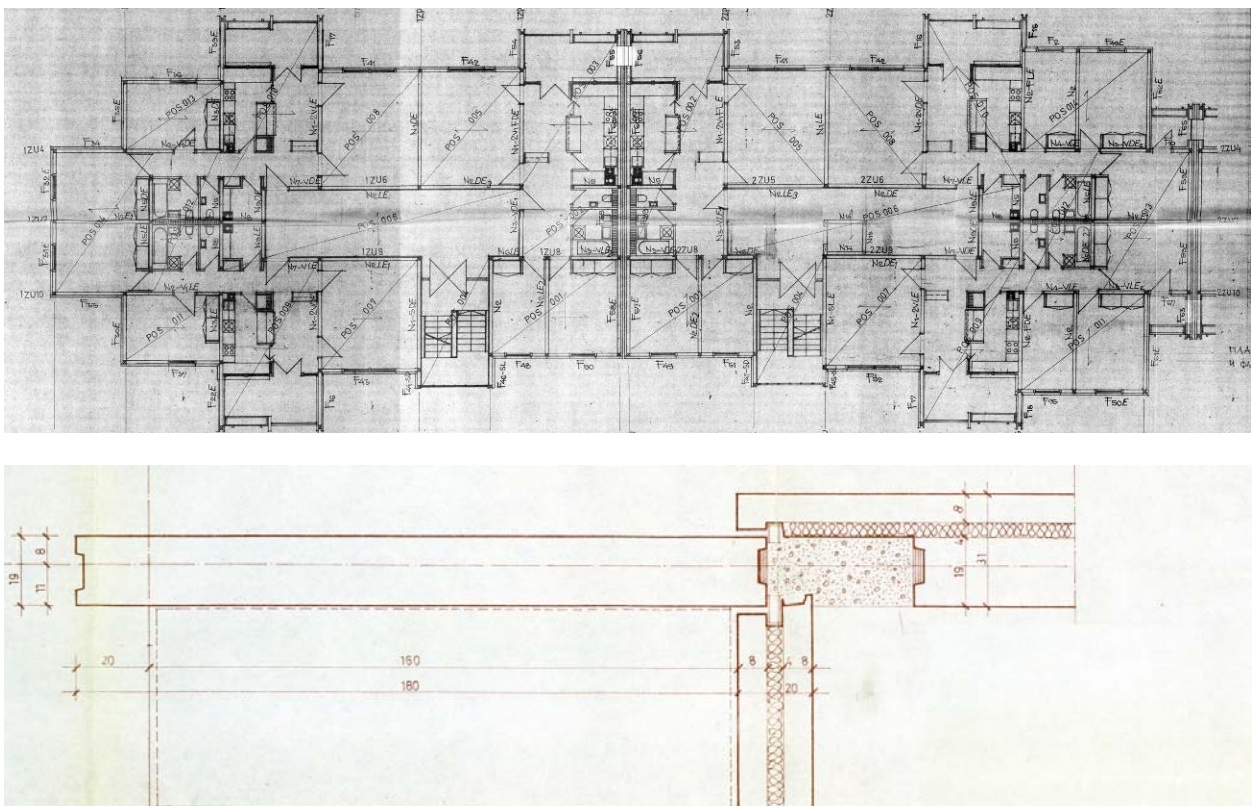

Figure 93: Block No. 64: Building model - Rad-Balency system(above); Joint detail of façade panel and interior partition (left); cross section (right) - (see: Appendix - Block No.64 : Building No.04 B1)

6 Morphological characteristics of industrialized housing model

The selected industrial housing examples represent different building technologies and prefabrication techniques as well as a different housing typologies. The case study examples have been analyzed from different aspects:

- Technical aspects refer to a building technology for the load-bearing structure, façade, walls, roof; the assembly procedures of components and.
- Functional aspects refers to morphological characteristics of the building layout and dwelling layout (dimensions, number of floors, number and structure of dwellings);
- Environmental aspects are energy consumption, a life circle of building components and assemblies; CO₂ emissions, waste disposal, etc.

6.1 Functional aspects

It is necessary to accurately analyze all the potentials of industrialized housing to generate flexible, adaptable and transformable space. The functional organization and possibilities for transformations are two of the most important motives for industrialized housing refurbishment.

6.1.1 Relations between spatial and technical systems

The relations between dwellings and technical systems are significant, as well as their combinations with other organizational systems (corridors, vertical communications, basement floor). The industrialized components for installations (blocks and walls) placed in the service zone of the flats as independent part allow greater flexibility for the functional organization inside the dwellings' limits. Connections for water, sewage and ventilation systems may be organized in certain parts of units around their edges, depending on the purposes required. Therefore, such units may rely on fully **clustered model** for a kitchen, bathroom, toilet, storage, corridor, internal vertical communication (Kubet, Carić, & Hiel, 2010).

6.1.2 Construction module

An overview of the general properties of the industrial systems for apartment buildings has been described in the Building Model, system configurations and their assembly. On the basis of the applicable standards and regulations in the field of construction the basic module was $M = 10\text{cm}$. The designers, technologists and artists in the industry used $M = 10\text{ cm}$ to build housing, adopted its construction module that is equal to $3M$, and $6M$, while the height of the primary module remained unchanged - $1M$ (Jovanović et al., 2011). Module 60 ($M\ 60$) is still a basic measure used in the design of residential buildings in Beograd. Whether the meter system ($6M$) or in the system module 60, a use of modular coordination is a base for the design of prefabricated structures, the distribution of installations and many other systems and elements.

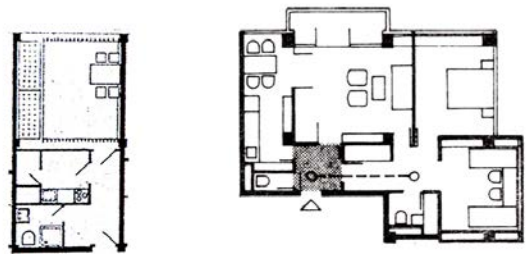

Figure 94: IMS building technology: Minimal social dwelling versus luxurious apartments.

In Figure 94, we can observe the IMS housing model and its progression in terms of spatial shames development from a minimal single-room dwelling (Block No.2 condominium building) to a luxurious apartment (Cerak Vinogradi), using the construction span of 4, 20 x 4,20 m.

6.1.3 Housing typologies

The most designed building typologies are simple building layouts: 3-4 units on the floor (tower building in block 1 and 2 with 8 dwellings per floor) in a building with 1 or 2 stairs, sometimes 4 (lamella buildings) with 5 to 11 stories. The ground floor is used for garages or storage rooms for waste (the waste chute is noisy and smelly). During the last 10 years big part of the garages have been converted into tiny shops or pubs. The biggest problem with the buildings is a lack of continuity between the flats, communal areas and urban areas. It is necessary to create a mixed-ownership, mixed-use, and a wider palette of flats in term of size and functional disposition as well as provide transformations in buildings.

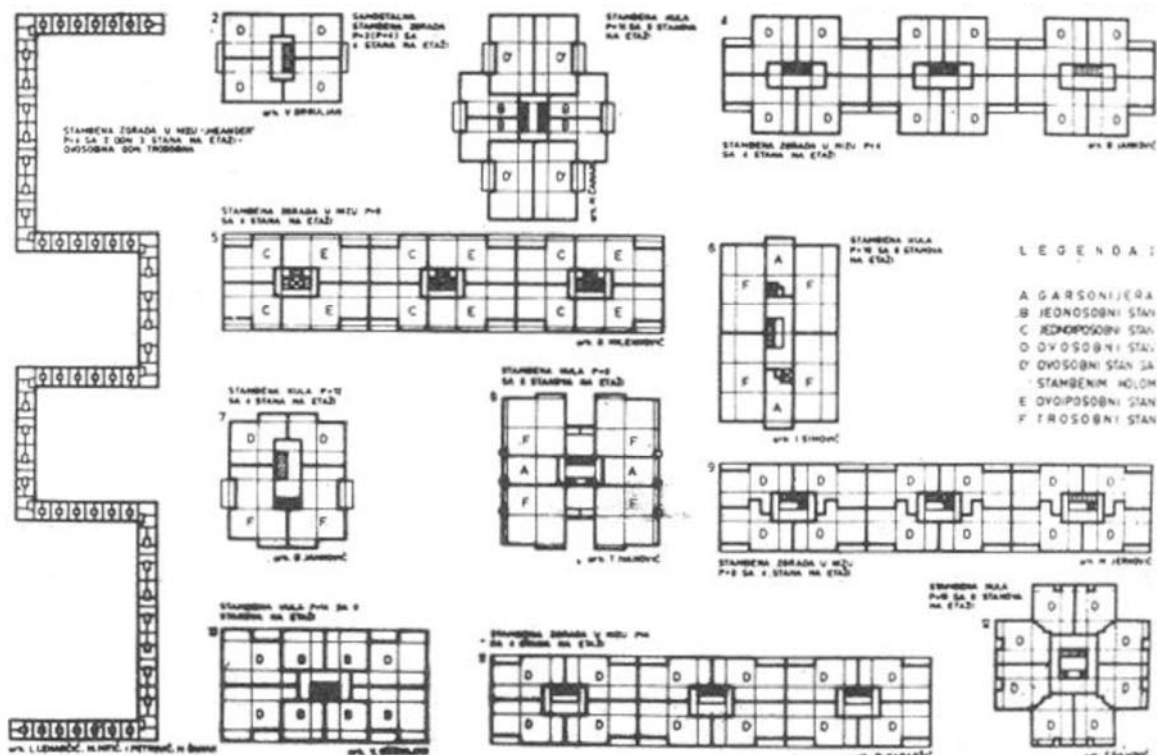

Figure 95: A view of the characteristic housing layouts in IMS modular grid 420/420 cm (Canak, 1970)

Different housing layout schemes in the structural module 4.20 x 4.20m are presented (Figure 95). An important feature of the IMS skeleton is flexibility for design of a variety of housing models and dwellings' schemes. The flexibility of the IMS housing is defined:

- The building structure was an integral part of the design process (interdisciplinary analysis of architectural design);
- Producing the smallest possible number of component capable of being assembled into the greatest possible variety of BM;
- Assembly hierarchy of prefabricated components and;
- The IMS building technology has successfully been implemented in the production of high, medium and low-rise housing;
- 'Open' technology of prefabricated construction;
- New componenets and systems can be integrated for sustainable refurbishment of industrialized housing buildings in the future.(Jelena Nikolic, 2013a)

- **Apartment position in the building**

The apartment position and its relation with the façade are really important for the quality of the dwelling. Three basic positions can be distinguished:

- a) Double-sided orientation (corner flats)
- b) Double-sided orientation (two-opposite-side)
- c) One-sided orientation.

Cases a) and c) are applied to tower buildings and row apartment buildings. The conditions of the natural ventilation and insulation are favorable but mostly important for the interior flat organization. This is almost always a trait of two-room dwellings. Case b) is a bigger apartment characteristic for the lamella buildings when they have a north-south orientation. The conditions for insulation and ventilation as well as the functional possibilities, are very good. Provides an optimal justification of the rooms: In the central zone are the entrance area, the bathroom and a lavatory. The sleeping area is located on the northern side with a view on interior courtyard and the living area, is oriented to the south. One of the more important conditions for achieving high sustainable performance is good natural ventilation, which is achieved easiest by having double sided apartments for cross ventilation.

- **Grouping flats around vertical communication - tower building**

The organization of the dwelling units around the vertical communication was the most applied solution for the unit's disposition. Towers and buildings with the interior communication corridor are common solutions, the layouts with exterior corridors or open galleries are very rare. In three corridor buildings the lateral stairs on which two to four dwellings are connected, are isolated from the dwelling space with a service room. In some examples in this tampon zone are lifts, but in others the lifts are joint with the

stairs. The stairs are interior, in the low-rise buildings with natural lighting, but in the high-rising buildings always with artificial light source. The lack of the fire protection of construction elements of different functional zones makes this buildings not improved for the current standards. The fire protection regulations are not always strictly obeyed. In the B+8 buildings the fire isolation of the vertical communications and fire stairs doesn't exist. The towers building are rare in comparison with lineal buildings. A larger part of the realized project contains four apartments on the floor around the central vertical core, there are few solutions with five, six and eight flats (Figure 96).

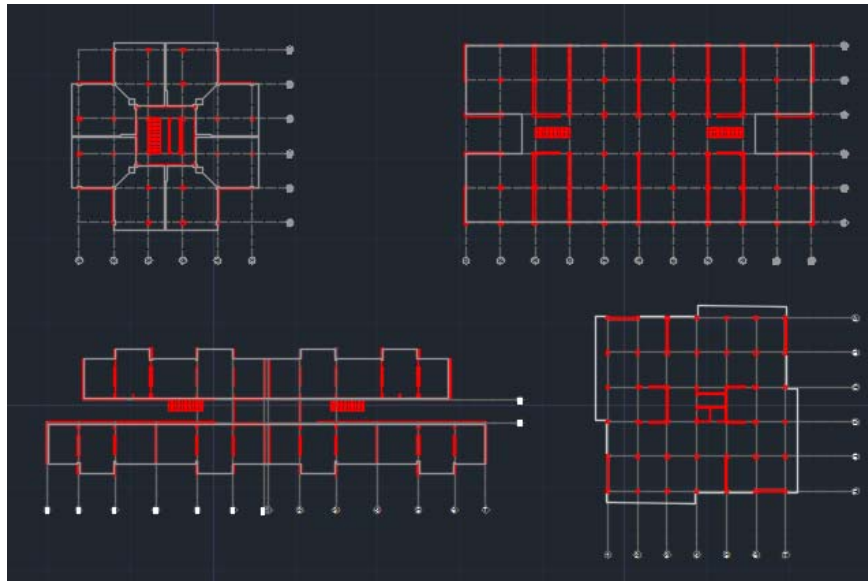

Figure 96: Different dwellings arrangement in the IMS building model (red color - load-bearing system)

The buildings are designed with or without console (cantilevers) with variable main module to generate diversity in the layouts. The vertical staircases are artificially illuminated and ventilated, mostly as straight-flight of stairs and without any fire protection which is the serious problem. All the central facilities and services (stairs, bathrooms, cleaning rooms, WC-s, and all communications) are inside the building core, in that way all the apartments have two-side orientations. This kind of solution supports the initiative to exploit the maximum of the living space.

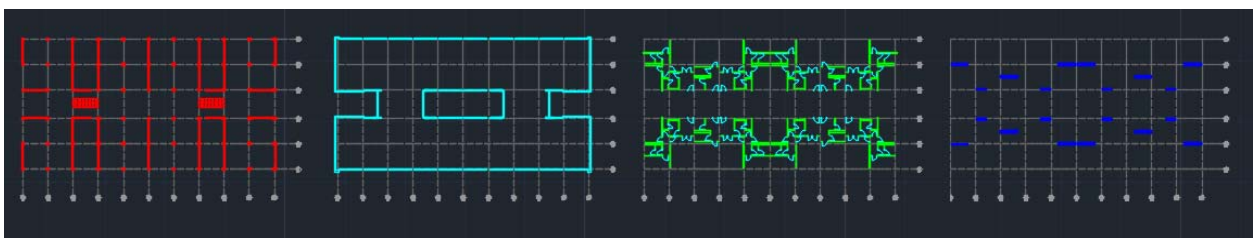

Figure 97: Block No.2: Condominium housing - Building Model decomposition

Condominium housing is designed with various lamella volumes, with 3 to 5 cores. Dwellings are organized around the stairs (vertical communication core) with 4, 6, 8 units per core. Most of the

developed row-building-blocks adopted the structural span of 4.20m and a three corridor layout with the possibility for cantilever extension from both sides. The layout scheme with two corridors (layout zones) had been analyzed and rejected because of the long façade for each dwelling. The use of structural grid of 4.80m allowed more options and flexibility in flats organization. The production of 4.80m long façade panel was realized in situ.

The organization of the tower buildings with a various numbers of dwellings had been realized in both construction systems (skeleton and huge panel system) - Figure 98. All flats have the optimal conditions of the natural ventilation and insulation.

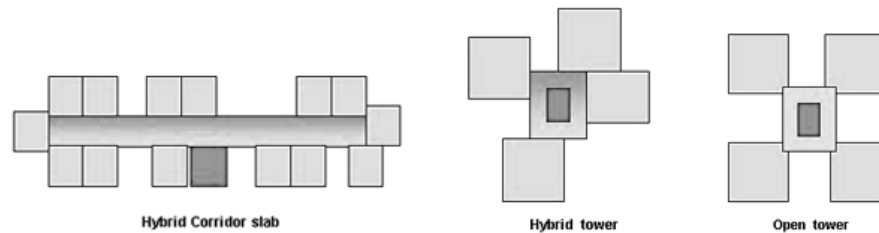

Figure 98: Dwellings disposition around vertical communications in tower buildings

The organization with three dwellings per stairs had been applied in Meander building. One three-bedroom flat has a double orientation, and the two-bedroom flats with a single orientation. The stairs core has a central position with the natural light from the roof which was possible for a 4-story building. (Figure 99).

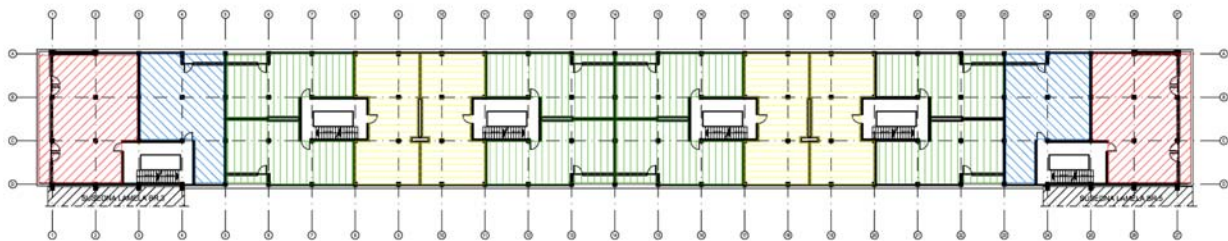

Figure 99: Block No. 21: Meandar building typical floor plan

6.1.4 Dwellings' typologies

The best examples of the dwellings' typology have been realized in the IMS construction system. To understand its evolution and the transformation capacity, two parameters are analyzed:

- **Dwelling's structure** – a cluster of spaces and rooms with specified function (sometimes one room has a complex function). According to the apartment structure we will analyze the capacity for transformation and the possibilities for functional adaptability.
- **Dwelling organization** – functional relations, position of the rooms, dwelling zones and the way and efficiency of interior communications.

The two-bedroom apartments as the most applied typology in the post-war industrialized housing had been modified many times to satisfy different users' need. Lack of space had created a dwelling with multipurpose room. The living-room was used as the sleeping area and very often the access for the sleeping area. The organization of the dwelling has the same importance as its structure, because undesired interior relations may disturb everyday life. The structure of the observed apartments varies from a one to four-bedrooms. The one-bedroom flats are designed with the dining and cooking differentiated by depth, but not completely divided (Figure 100).



Figure 100: One-bedroom apartments (one and a half bedroom), (Canak, 1970)

In the two-bedroom dwellings, the kitchen with dining area are differentiated by depth and completely separated from the living area (Figure 101). Also, there are schemes without separation of the zones, where the dining area is a part of the entrance corridor. Two-bedroom flats are evolving toward two and a half bedroom flats with one little room. Bigger apartments have one bathroom and one WC.

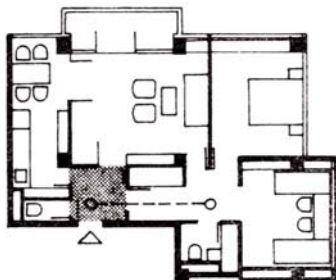

Figure 101: Two and a half bedroom apartment, (Canak, 1970)

Three and four-bedroom flats are considered expensive and were designed in a small number. These apartments are divided into day zone and night zone.

The bigger two-bedroom apartment has a fixed core with the kitchen, WC and dining area. Around this 'nucleus' is free space for a variety of rooms dispositions (Figure 102). Many combinations have been developed, each with two/three variations. The rooms are divided by mobile partitions and they are easy demountable. Finally, we have various polyvalent rooms adapted for activities during 24 hours. There are few projects where the sleeping rooms are placed around the central wardrobe which is in direct contact with entrance hall (Figure 102).

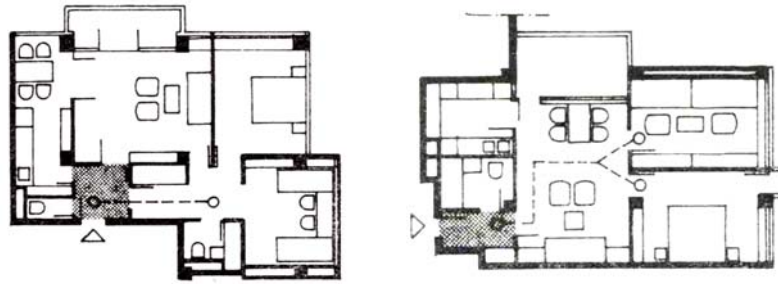

Figure 102: Two and a half bedroom apartment with the circular room disposition (left); Two bedroom apartment with the one direction communication (right), (Canak, 1970)

In some examples, the communication with the sleeping area is through the living room directly from the entrance corridor. The rooms are organized around the wardrobe connected with the bathroom or linked directly with the living space that serves as the living 'hall' (Figure 103). The negative aspect of transit through the living room were resolved by providing the secondary communications through the kitchen (Figure 103). Circular communication is provided without overloading particular spaces.

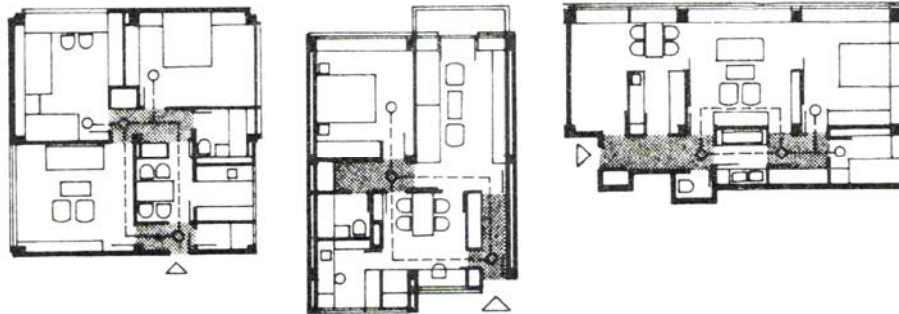

Figure 103: Circular communication in the dwellings (Canak, 1970)

Grouping the rooms around the entrance area has a special sense if it is shaped in a form of the entrance hall with the dining room. In some cases, the central area with two polyvalent rooms becomes huge enough. A very common distribution is a flat with kitchen just beside the entrance hall and the dining room in continuation, beside the window (Figure 104).

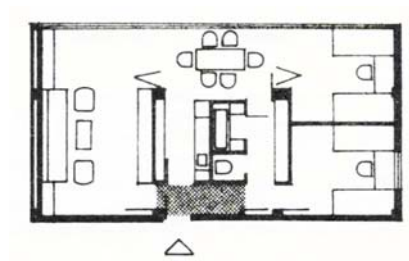

Figure 104: Kitchen and dining room derived from the entrance corridor, (Canak, 1970)

The living-room is almost always one unique space, very rarely it is divided into primary and secondary zone. The idea was to connect the living room with the other rooms in the flat, especially with the dining room and one sleeping room. This kind of schemes allows formation of the continuous space with

polyvalent use. Every dwelling has its own 'pattern' which could be modified. This flexible space is due to the flexibility of the IMS supporting structure.

The large panel building models (Rad-Balency housing models) limit the layout flexibility with the transversal load-bearing walls. In all variants of flats, the designers insisted on double and circular links "to give the impression of spaciousness and to improve the functional relationship.

6.2 Structural aspects

6.2.1 Building Model (BM) design

The strategy recognizes the need for adaptability and requires analysis of the independent parts that could be upgraded (replaced, reconfigured and reused). The building structure is defined as a hierarchical arrangement of elements and their relations. It represents the way the main functional and technical parts are placed in the components assemblies. The evolution of the building structure represents the transformation from the complex to the simplified connections. The first step towards simplification of diagram's relations has to do with clustering the elements into independent subassemblies, which will act independently in production and assembly process (Figure 105).

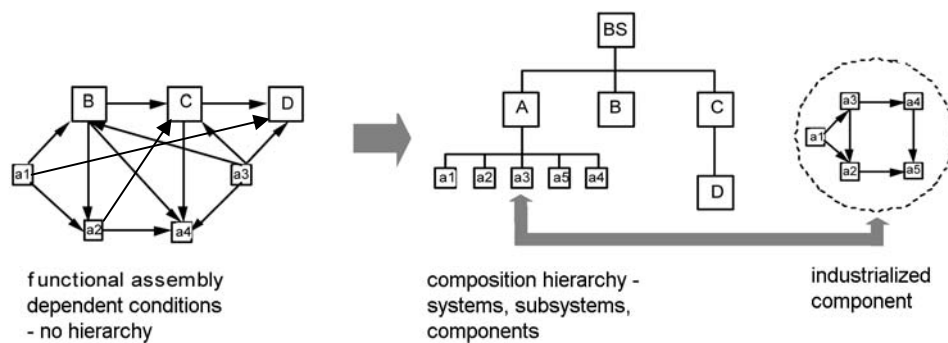

Figure 105: Components assembly: From dependent conditions to systematic hierarchy assembly

There was a permanent change in terms of applied technology for different buildings, as part of each industrialized construction system for housing. The permanent changes of the evaluable industrialized technologies occurred according to the requirements of individual housing project. The base of each building is the constructive, load-bearing assembly. There was a dual nature for building development and two parallel ways for its realization. From one side, the constant subject of design in post-war housing rebuilding process were flats' layout and from the other building models (design of roofs, façades, partition walls, installations). To allow more design options for the dwellings, load-bearing structure was built as an independent assembly of prefabricated components (IMS building technology, RAD- Balency huge panel system...). The load-bearing assembly started to be analyzed and designed for spatial flexibility (flats orientation, cross ventilation, balconies and loggias, separations of the day and night zones...).

6.2.2 Structural adaptability

- **New integrated approach which is flexible and demountable**

The main parts of the building system are its sub-systems. If all subsystem's components are put together by fixed connections the model is 'closed' (Figure 106). Interchangeable components and subsystems offer an opportunity for many manufactures to participate in the system configuration. Industrialized system configuration can offer increased adaptability to changes through the precise jointing features of the factory-made components and sub-systems. Since the most factory-made components or sub-systems are designed to facilitate site installation, they could also be dismantled to generate changes without any demolition.

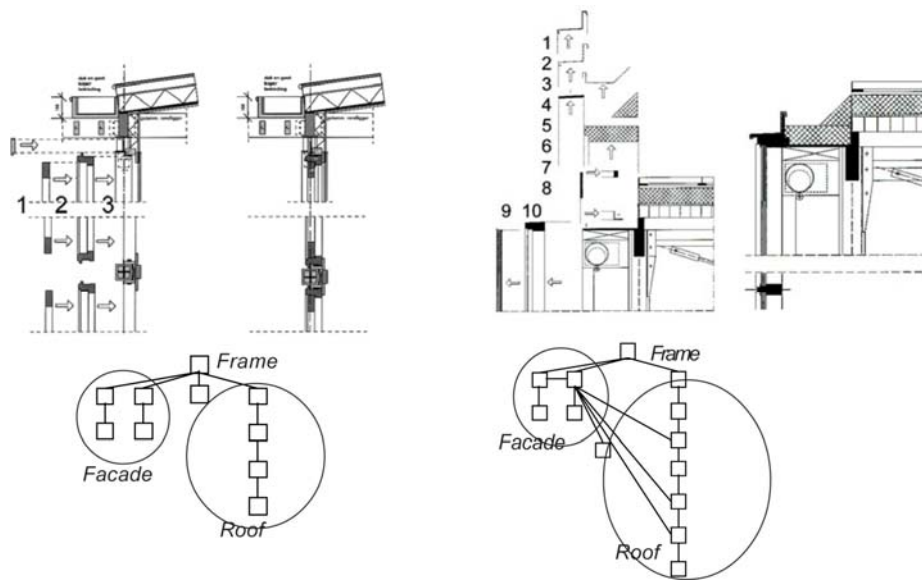

Figure 106: Disassembly hierarchy and relational diagram: Left: Transformable configuration; right: Permanent configuration - lack of transformation potential (Durmisevic, 2006)

Systematization of the sub-systems and components in one system configuration corresponds to the main structural functions: load-bearing, enclosing, partitioning and servicing. According to the main functions, corresponding technical levels are established: a load-bearing structure, building envelope, partitions and services. The systematization of elements into the main technical levels is based on the hierarchy assemblies where components and materials make connections by simple and demountable dry joints. The hierarchy assemblies define the three systematic parts where the elements lower in the hierarchy will change with more frequency. Demountable joints allow for the fast-changing components to be independent and to be replaced at the end of life. Open system that can exchange parts, components and subsystems outside its original production contest are considered “interchangeable” and compatible. The interchangeable components and systems offer an opportunity for many manufactures to participate in the system configuration design and future upgrading.

6.2.3 Transformation capacity of industrialized housing

The transformations capacity of these buildings depends on the production technology, the way of connecting structural elements, the composition of the elements, the reinforcement, the configuration of the contact areas of the elements and the system of joints.

The main objectives of the housing industry to achieve the flexible and transformable models are:

i) configuration design of the building structure; ii) integrated models by simple and dry joints; iii) independence and exchangeability of components and subsystems; iv) adaptability progression in the network between spatial and technical systems. This research shows that the transformation capacity of the total building strongly depends on the transformation capacity of the building model composed of different subsystems and components and the way they are put into connections. The study focuses on assembling and connecting to get better understanding about the way they interface, in order to facilitate refurbishment while minimizing waste.

6.3 Environmental aspects

During the expansion of the prefabrication in Beograd, in a period of economic prosperity, architects and constructors did not pay too much attention to the ecological aspects of the construction. The enormous residential building stock became the biggest energy consumer, next to the transportation, industry and commercial facilities. Using an appropriate methodological approach, the disadvantages of existing buildings, considered to be "massive housing" difficult to adapt, are analyzed from the environmental aspect to evaluate the possibilities for sustainable refurbishment and transformations on spatial, technical and environmental level.

The industrialized housing and its' special form of integrated prefabrication from the second half of the 20th century needed retrofitting to comply with the contemporary demands of housing. The Directive¹⁵ (*The Construction Products Directive*, n.d.), sets the rules for thermal comfort and energy savings. During residential building service life, it is necessary to monitor the building model performance through regular inspection of deterioration and other defects, to investigate and detect the emerging problems and control the appropriate maintenance works (Gulvanessian & Calgaro Holicky, 2002). The energy efficiency, especially the thermal protection of buildings is a problem whose solution will also include the issues of the technological, economic, social and legal rights (Folić & Laban, 1995). Therefore, the energy rehabilitation measures could be set as compatible to the other building renewal activities according to the Building Model (BM) composition and its transformation capacity.

¹⁵The Construction Products Directive (Council Directive 89/106/EEC), available: <http://eur-lex.europa.eu/LexUriServ/LexUriServ.do?uri=OJ:L:1989:040:0012:0026:EN:PDF>

In the first housing projects, there was no thermal insulation. The first requirements concerning thermal insulation date back to the building code of 1948 and had been applied only to the roof. Since then, the requirements have been steadily increased.

7 Functional, Structural, Energy-efficiency analysis of post-war housing in Beograd

7.1 Introduction

Physical properties of the building envelope, the use of different materials with the characteristic textures and colors and the different forms and shapes of the façades are the result of the mass production of housing in Beograd. If we consider the possibility of revitalization and reconstruction of the industrialized housing, we have to deal with the issue of renewing or replacing its outer shell (façade and roof) and to upgrade the joints between the components and subsystems. According to the graph model report for the industrialized housing model connections and joints (edges and nodes), it is possible to approach a scenario of the integrated refurbishment of the building's envelope. **The integration of retrofitting strategies defines a method for housing refurbishment based on more flexible edges and nodes (the connection between components and subsystems in the industrialized building model).** The refurbishment scenarios based on the improvement of individual envelope elements (windows, flat roof construction, parapets, balcony fence...) or groups of elements (roofs, façade panels, balconies...) and finally the envelope as a whole - allows for the refurbishment process to be realized in phases to manage the economic incomes. The independency of the building envelope from the load-bearing system and the internal independency of its major components (wall parapets, balcony fence) allow the transformation of the envelope for upgrading of the dwelling comfort and less negative environmental impact. Refurbishment strategies of the façade will include upgrading process of systems and components (clusters and nodes) on different spatial and technical levels. The spatial transformations and dwelling comfort are included too. Any change of the building envelope will not influence the load-bearing system.

The flexibility and transformation capacity of the low-rise and mid-rise buildings are analyzed to support functional, technical and comfort changes at dwelling level. Different scenarios for the transformations of the building envelope and improvement of the dwellings' comfort has been analyzed: i) improvement of the energy performance of industrially made buildings by the improvement of energy efficiency of the building envelope; ii) spatial transformation of the dwellings layout by transformations of the building envelope). By adding balconies or sunrooms will help to change the monotonous view for the housing blocks that are not under the modern heritage preservation. Any change of the envelope and load-bearing structure depends on the type of connections between these systems, their components and can be analyzed from Graph Model (GM) diagram.

During the last 3 years, the measures of massive housing refurbishment have been undertaken and financed from the state. There was financial help to change the wooden window frames with airtight PVC windows (the problem of mould emerged very soon around the windows frame). In some cases, the

heating system has been changed and local heating systems were introduced. In some cases, boilers were introduced to every flats.

7.2 Great value vs. poor condition

The preparation of energy balances in the Republic of Serbia began after the adoption of the new Energy Law in 2004 and the first Energy Balance was adopted by the Serbian Government in the same year and it was published in Official Gazette of the RS, No. 133/ 2004. This Energy Balance contained the data related to the expected energy production and consumption in 2004 and the plan for 2005. After the first Energy Balance, the Government has been adopting the energy balance each year for the following year at the recommendation of the Ministry of Mining and Energy, by October of the current year at the latest.

All of the post-war housing building use energy for heating, cooling and lighting. In addition, there are serious problems with energy losses between the heated (flats) and unheated areas (halls, corridors, staircases). These conflict situations are mostly resolved with a panel of insulation material which is mostly poorly executed. This affects the construction, mostly because of the significant amount of water being captured between the construction and insulating layer allowing mold and fungus to be reproduced on the inner side of the construction element. These repair measures performed by the tenants lead to diminished living comfort and to the degradation of buildings. The situation gets even more complex when the variable of ownership is added. The housing blocks all over the former Yugoslav states are in mixed ownership. Till now, all the deterioration problems of the building envelope cause a rejection as well as a lack of hope that changes are possible. There is neither an institution, nor strategy that would offer the residents to resolve their inadequate housing conditions. The envelopes are undergoing the retrofitting process by tenants themselves. They are trying to increase the living comfort by lowering heating losses in winter and solar gains in summer. As a result, some tenants have replaced their windows or added a new isolation layer to "seal up" the thermal bridges. The flats have been enlarged by enclosing the narrow balconies, terraces or loggias for more energy efficiency. As an independent the envelope has been the subject of uncontrolled transformation by non-experts. The energy retrofit issues of prefab-buildings will be assessed from the point of sustainability and possibility for achieving maximal savings without affecting the quality of living and historical value of the building.

After all, illegal and unskilled interventions on the building's façade have been done by the residents: the transformation of loggias into residential space as a living-room extension or an extra bedroom, storage or kitchen; upgrading of the energy performance of the façade, functional transformation of the dwelling space by changing position of the partition walls, complete enclosing of the balconies an loggias (Figure 107). Besides sloppy impression and unfinished appearance, those interventions also contributed to the façade deterioration process due to bad insulation, ventilation and mold growth. The building's façade is undergoing the process of uncontrolled transformations and deterioration.



Figure 107: Balcony and loggia transformations - (Block No.21, Building B9): foto by Sonja Jurosevic

Since we are dealing with prefabricated elements completely industrialized and embedded, or partly manufactured on the building site, one must think about the joints between these elements and thermal bridges which occurred immediately. E.g. in concrete housing blocks we have a balcony where the concrete is direct connected without any insulation to the interior of the dwelling.

In order to provide qualitatively and quantitatively valid information about prefabricated and semi-prefabricated building envelopes, it is necessary to perceive the technical condition of the envelope and its structural characteristics. The type of connections between the envelope and load-bearing structure (cluster-cluster relation) as well as the connections between their components are significant for the refurbishment process. An important advantage of the industrialized housing models is systematization of components without fixed cluster-node joints. This was obvious mostly on the parts between the gable and the roof slabs; façade cladding and floors. Weak insulation materials and inadequately performed joint between these elements have been a problem after a few heavy rains. Also, there has been a problem with the panels: insufficient thickness, inappropriate materials, lack of insulating materials, short path of thermal conductivity plain, poorly insulated joints between window panels and shutters, screens and jalousies.

These execution details in combination with the atmospheric water, air pollutants and continental climate were excellent predispositions for allowing mold and fungus to be produced inside of the building construction elements. In addition, there are serious problems with energy losses between the heated (flats) and unheated areas (halls, corridors, staircases, oriels).

7.2.1 Building envelope transformations

The main focus is on the technological issues of the building envelope, its influence on ecology and energy savings, the technology of connections and transformation capacity. The most common façade transformations are windows replacement and converting the loggia in the living area (Figure 107, Figure 108). The tenants themselves are trying to obtain tight-fit interior comfort without air infiltrations and heat losses in winter and at the same time to obtain more. Normally, this new skin contains poor conditions. Single (rarely double) glazed windows with a wooden frame have very poor thermal

conditions. All the so far replaced windows in the Meander building are presented in Figure 108 (see Appendix - Block No.21 : Meander building).

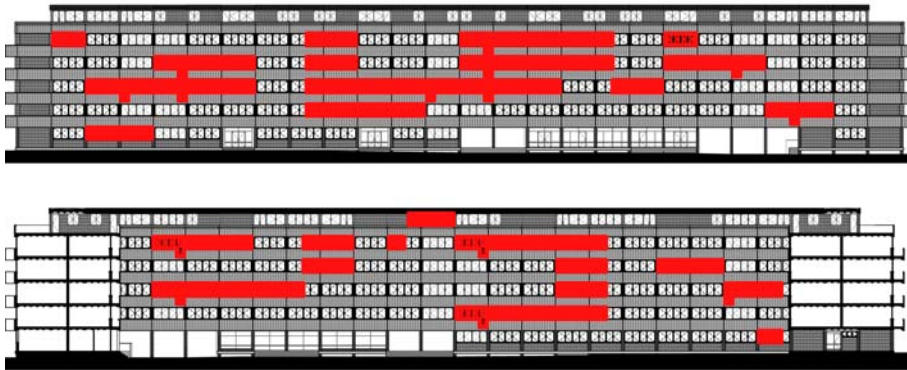

Figure 108 : Windows' replacement: Northeastern façade (above); Southwestern façade (bellow)

- **Enclosing of loggia**

There are many problems with the vertical enclosing (Figure 109): insufficient thickness, inappropriate materials, lack of insulating materials, short path of thermal conductivity plain, poorly insulated joints between window panels and shutters, screens and jalousies. The lacks of the building models are joints between elements when thermal bridges occurred immediately. To obtain less energy losses the loggia and balcony space has been closed, adding a row of windows above the loggia parapet (Figure 109).



Figure 109: Joint between column, slab and parapet element: presence of thermal bridge

One of the most common thermal bridge is presented in Figure 109 between four structural components: load-bearing column, slab, window, and façade parapet wall. The tenants put paper to seal up the holes of despaired insulation material. The thermal bridges are obvious between the windows and columns; columns and parapet wall.

7.3 Current status of industrialized housing

7.3.1 Load-bearing structure

The load-bearing structure life span is much longer, if we compare the current status of the building envelope and the possibility for upgrading the dwelling units according to users' needs. The observed damage of the load-bearing system is mainly due to corrosion and uncontrolled human interventions, coupled with the lack of maintenance. The study was conducted in collaboration with the IMS institute to support the development of measures and actions to repair damaged items, to restore their strength capacity and extend its life. The most common injuries are reflected in Table 3. The results from the analysis allowed a study of the state of materials and corrosion activity of steel reinforcement requested.

Structural element	Damages
Floor slabs	Presence of steels exposed to corrosion. Drilling for pipe laying. Excessive humidity.
Beams	Humidity
Columns	Loss of coating steel. Steel exposed to the presence of corrosion. Loss of concrete section. Delamination of reinforcing steel.
Stairs	Steels exposed to the presence of corrosion.
Bathing area, kitchen and service yard.	Excessive humidity. Leaks of hydraulic lines. Breaks of sanitary pipes. Moisture from the plumbing networks in poor condition. Interventions of the inhabitants

Table 3: Degradation of construction elements in IMS Building Model (Flajs, 2013)

The current state of materials and corrosion activity of the reinforcing steel are present problems of the load-bearing structures. The main causes that justify the emergence and development of corrosion process are the environment in which the buildings are locked, the CO₂ in the atmosphere and the presence of moisture. The exposed steel is oxidized. Corrosion is a typical lesion that damages steel due to the presence of moisture. Corrosion can decrease or completely destroy a reinforcing steel section and thus reduce the bearing capacity of an element. Different structural spots are observed, taking into account the state of apparent deterioration. These areas include columns, beams, slabs eardrums and mezzanines, parapets, cornice, balcony fence. The study included the following:

- Determination of coating thickness of reinforcing steel: essential to ensure the durability of concrete requirement;
- Determination of the carbonation depth: refers to the process in which carbon dioxide from the atmosphere reacts with the alkaline components of the concrete (Flajs, 2013). If the humidity is greater than 80% and temperature cycles vary in both day and night and throughout the year, moisture contents can appear and this would lead to significant corrosion (Flajs, 2013).

- Determination of the presence and concentration of chloride ions vs. concrete mass: chlorides cause a localized dissolution of the passive layer, resulting in damage to specific attacks (pitting) that can dramatically reduce the working section of the steel in a relatively short time.
- Determination of potential corrosion of reinforcing steel: The results of the measurement of potential corrosion of reinforcing steel.
- In 25% of the studied areas, the carbonation depth reaches the coating thickness of reinforcing steel, indicating conditions conducive to the widespread occurrence of corrosion of the reinforcing steel in them.
- In 47% of the studied areas concentrations of chloride ions are detected in the concrete mass above the 0.05%, which are sufficient to cause localized corrosion of reinforcing steel.
- According to the obtained corrosion values at the time of measurement, corrosion risks, both general and localized, range from moderate to high. (Diéguez-Cruz, Calderín-Mestre, & Ruiz-Ruiz, 2010).

7.3.2 Building envelope performance

The thermal protection of the buildings was mostly regulated by the standards of SRPS U.J5. series¹⁶. Figure 110 shows the regulations for the envelope performance with the value of the coefficient U for the external walls and the corresponding industrial building systems in use.

Period of application of regulations	Calculation of the building's thermal protection Value of the coefficient U for the external wall			Industrial building systems in use
	Climate zone I	II - Beograd	III	
1961 through 1967	No limitation, calculation according to DIN 4701/1947, 1958			IMS
1967 through 1970	Overall thermal transmittance coefficient U values defined [$\text{Wm}^{-2}\text{K}^{-1}$]			IMS TRUDBENIK
	1.54	1.33	1.18	
1970 through 1980	Reduced maximum value for the coefficient U [$\text{Wm}^{-2}\text{K}^{-1}$]			IMS RAD-BALANCY
	1.45	1.25	1.10	
1980 through 1987	Reduced maximum value for the coefficient U [$\text{Wm}^{-2}\text{K}^{-1}$] and included the summer mode into the calculation			IMS RAD-BALANCY
	1.225	0.930	0.830	
1987 through 1990	coefficient U without changes, the building's specific heat losses defined			IMS RAD-BALANCY
1990 through 1998	1.225	0.930	0.830	
1998 through 2012	Reduced maximum values for U			The industrial building systems are no longer in use, except the IMS
	1.10	0.90	0.80	
From the October 2012	For existing buildings $U_{\max} = 0.40 \text{ Wm}^{-2}\text{K}^{-1}$			

Figure 110: Regulations for envelope thermal performance from the 60' (Folić & Laban, 1995) (Folić & Laban, 2006)

¹⁶SRPS U J.5.600:1998 Heat in civil engineering (HCE) Requirements for design and manufacturing of buildings; [5] SRPS U.J.510:1987 HCE Coefficient of heat transfer in buildings; SRPS U.J5.520:1997 HCE Calc. of water vapor diffusion in buildings; SRPS U.J5.530:1997 HCE Calculation of damping factor and temperature oscillations delay in the summer period through the exterior building partitions

New codes on energy efficiency and certification of buildings were adopted, in accordance with¹⁷, whose implementation started in October 2012¹⁸. These regulations limit the maximum allowed annual energy consumption for heating to $70 \text{ kWhm}^{-2}\text{a}$ for the existing buildings. The average annual energy consumption in the residential buildings in Serbia exceeds $150 \text{ kWhm}^{-2}\text{a}$, while in developed European countries it is approximately $50 \text{ kWhm}^{-2}\text{a}$ (Šumarac, Todorović, Trišović, & Djurović-Petrović, 2010).

- **Horizontal enclosing - Roofs**

Almost 98 % of the housing blocks were built with poor insulated flat roofs or easy sloped (5%). No terraces or green roofs had been built. Generally, we have very big flat roof surfaces with a very poor water proof layer. The existing layer made of bituminous material is mostly damaged. In some houses the attic is heated, in others the attic is only used for storage. Most attics have heating losses above 150 (kWh/m²a). As well as for the façade, the regulations force the owner to take energy saving measures into account for the refurbishment of housing in Beograd.

The flat roof design with an inward slope, interior drain pipe system and an exterior drain pipe system as well have many problems with water infiltrations and moisture. Some exterior drain pipes are broken and rain water directly hits the façade. The upper layer of the flat roofs can be ventilated underneath or not. Thermal insulation is installed on the top ceiling, but in many cases is damaged. There are no roofs that use vegetation as an additional insulating and protecting layer above the exterior plastic foil.

- **Vertical enclosing – Façade**

The façade was designed as the enclosing of the load-bearing structure, without the application of knowledge about the building physics. Built poor and due to their aging, the envelopes' thermal performances are becoming permanently worse. The main causes for the multilayer panel damages are: poor water resistance, damages of the joints between panels (water penetrates into the isolation layer); concrete protection layer of the steel bars damages because of the improper placement of the steel during the production process; mesh cracks due to shrinkage). The most common are ventilation losses, through the windows of low quality, regardless whether they are poorly made or made from bad materials, or with no adequate glass. Ventilation losses are the result of poor quality of the embedded windows, or thermal bridges in the connection of windows with panel. Besides the ventilation losses, special attention is paid to the transmission losses, which are a consequence of the quality and energy efficiency of the façade.

¹⁷ Directive 2010/31/EU of the European Parliament and of the Council of 19 May 2010 on the energy performance of buildings (recast) Available: <http://eurlex.europa.eu/LexUriServ/LexUriServ.do?uri=OJ:L:2010:153:0013:0035:EN:PDF>

¹⁸ Rule on energy efficiency of buildings, Official Gazette RS, No. 61/2011; Rule on conditions, content and a way of energy certification on buildings, O. G. RS, No. 61/2011

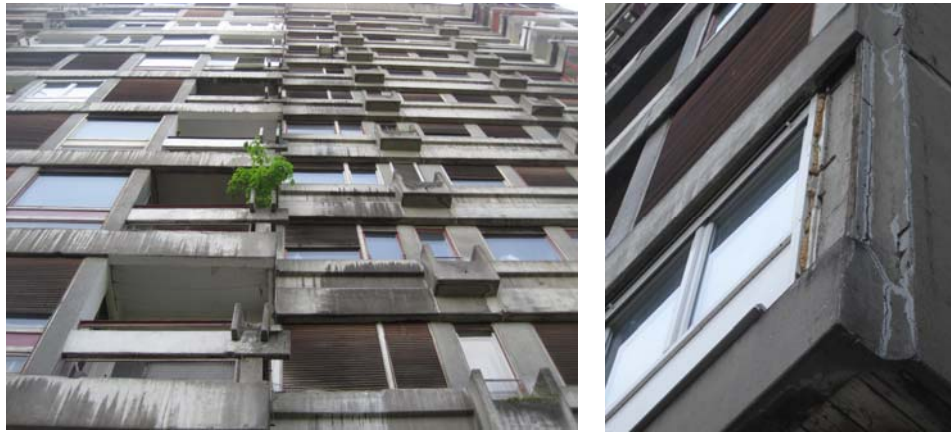

Figure 111: Block No. 23: Dilapidated façade panel with visible damage: Loss of concrete section. Steel exposed to the presence of corrosion; steel section loss; cracking of the concrete.

Constructed without or with inadequate thermal insulation, these buildings present the most serious problem of energy losses in Beograd today. Many of them have visibly damaged façades, moisture penetration into the walls (Figure 111) and a lack of indoor comfort, primarily inadequate air temperature with high infiltration of outdoor air, regardless of extremely high energy consumption of heating from the Belgrade district heating system and high consumption of energy for the air-conditioning units, leading to the increase or peak loads in the electricity network during the summer period.

CAUSES	DETERIORATION CAUSES	DEFECT
PHYSICAL	-freezing and thawing	-cracking
	-moisture changes	-shrinkage cracking, delamination
	-temperature changes and gradients	-cracking
		-curving of elements and plates
		-detaching of outer panels
CHEMICAL	-carbonation	-reinforcement corrosion (and spalling of concrete)
	-alkali -aggregate reaction	-cracking
	-salt crystallization	-delamination
	-etrigante reaction	-cracking
		-spalling
MECHANICAL	-dissolving	-decrease of frost resistance
	-deformations	-cracking
		-cracking of joints
		-curving
		-penetration of water to isolation layer
BIOLOGICAL	-biological growth	-mould problems

Table 4: Common defects in façades due to the different causes

A deterioration process of a building's envelope is conducted by imperfections in the building process and connections execution process. The most common deterioration causes, agents and defect are mentioned in the Table 4. Carefully planned upgrading strategies of the joints in the façade cluster will resolve major defects like cracking, mold problems, penetration of water into the isolation layer, curving of elements etc.

- **Interior partition walls**

The interior partitions of 8,0 or 12, 5 cm brick wall finished in mortar and painting is the most common solution for the space division. The interior walls don't have acoustic isolation. The same partitions are used for division of two dwelling units and for separation of the dwellings from the corridor area. The lack of the acoustic layer makes the dwelling's area affected by the noise from the street, stairs and neighbor dwellings.

Prefabricated concrete panels 10 cm thick are used as interior partitions for the huge panel Rad-Balency construction system. The lack of acoustic isolation causes bad interior comfort. The partition walls between the dwellings and non-heated space (corridor hole) don't have thermal isolation and cause important energy losses. The interior partition in the IMS construction system as the non-bearing components could be replaced or upgraded independently from the other building parts. The partitions in the Rad-Balency system are load-bearing walls which limit alterations within the dwelling.

To improve the sound insulation between the rooms of the apartment and in particular between the walls in common separating two different apartments, it is necessary to add plasterboard cladding. A Similar problem exists in the horizontal divisions of the two dwellings, one above the other. The floors are made of reinforced concrete but without any layer of sound insulation in the panel structures. The IMS skeleton technology applied a cassette slab with an inserted isolation layer.

7.3.3 Installation system for heating

The building heating system requires special attention for at least two reasons: the cost of energy and energy efficiency¹⁹ in the context of the sustainable development. Consideration here is restricted to the type of heating used in the residential buildings. Central heating is available for the 50% of the housing stock in Beograd²⁰. Electric heating is still widely used. The USAID *Serbia Heating and Energy Efficiency Program* (2001-2002) resulted in a substantial reduction in the electricity consumption (about 10 per cent of households switched to another source of heat) and increased public awareness of energy efficiency measures through a public campaign. Gas supply is restricted to about 8 per cent of households. The first built apartments are not yet supplied with central heating which implies the use of electrical power for heating. Because of the poor heating facilities, the tenants decrease the process of ventilation. This results in condensation, dampness and mold, and may easily lead to health problems.

¹⁹ EU assessment: "Compared to other countries in Western and Eastern Europe, Serbia has one of the lowest energy efficiency ratings".

²⁰ Implementation of energy efficiency policy in republic of Serbia, Antonela Solujić: Head of Department for Energy Efficiency

The families pay 30 % of their income for heating. The District heating system works inefficiently (30% of the generated energy utilized in the buildings themselves, a huge amount of energy wasted during procession and transport.) Improving thermal insulation and vapor barriers, will contribute to internal air quality and living conditions. Presence of the mold and dangerous materials, like asbestos, could endanger human health, so it is important to identify and eliminate them during the renovation process (Laban & Folić, 2012).

7.3.4 Environmental aspects of the Building Model

• Energy consumption

The official records from the Beograd institution of thermal power plants, based on the data regarding energy consumption for heating in the last two years 2013, 2014 (for the period from 15th October to 15th April), presents annual energy consumption for most Industrialized Residential Buildings over 300 kWh/m² and 200 kWh/m² respectively. The reason for such energy consumption is envelope structure in sense of thermal properties resulting in: i) thermal losses; ii) overheating of the building; iii) ventilation losses; iv) losses in the heating system; v) thermal losses by the thermal bridges.

As already mentioned, the main inconveniences of the building model come from the poor conditions of the 'integration' joints between the façade components and load-bearing system causing important thermal bridges and accordingly deterioration of materials and components. The average annual energy consumption in the residential buildings in Serbia exceeds 200 kWh/m². New codes on energy efficiency and certification of buildings has been adopted in accordance with²¹ and implemented from October 2012²² ²³. These regulations limit the maximum allowed annual energy consumption for heating by 70 kWh/m² for the existing housing. The building is considered energy efficient if the annual energy consumption meets the codes as well as the minimum requirements of thermal comfort. The thickness of the additional layer of external insulation should be determined in order to enable the achievement of the required overall heat transfer coefficient U [Wm⁻²K⁻¹], according to the latest standards (for existing building U= 0.4 Wm⁻²K⁻¹). Furthermore, based on the calculation of transmission heat losses in the façade wall, a comparative analysis has been performed on alternative solutions for the energy rehabilitation of façades (an additional outer layer of thermal insulation and the replacement of façade woodwork). Comparative calculations have been made for the winter project temperature for Beograd according to the actual standard (-12 °C), as well as the temperature specified by new standard (20 °C). The heat requirement is very high due to the low U-value of the façades, the high air-change rate, and the cold-bridges are responsible for bad thermal comfort during winter and summer.

²¹ Directive 2010/31/EU of the European Parliament and of the Council of 19 May 2010 on the energy performance of buildings (recast) Available: <http://eurlex.europa.eu/LexUriServ/LexUriServ.do?uri=OJ:L:2010:153:0013:0035:EN:PDF>

²² Rule on energy efficiency of buildings, Official Gazette RS, No. 61/2011

²³ Rule on conditions, content and a way of energy certification on buildings, O. G. RS, No. 61/2011

• *Dangerous materials*

The presence of dangerous materials is common. The biggest problem (for 40% of the building) is the presence of asbestos. Asbestos was used as insulation material (in cellars, corridors, pipelines), and in other cases as fire-protection material. The asbestos itself was covered with textile and painted by oil-paint. During the decades the surfaces had been damaged and asbestos emerged to the surface.

The buildings, carpets, solvents, glues usually contain formaldehyde and toluene. If there was any renovation work during the last decades, it is sure that the applied new floor-coverings, wall-paintings, wall-papers were more dangerous. Reduced filtration ratio raised health problems, asthma and allergy.

• *Lighting*

Lighting performance is usually good. The geometric parameters of the buildings help good day lighting in the rooms and kitchen. Because of the standard design, the north and south façades have the same elevations and window sizes. Some bathrooms and toilettes have no natural daylight. There are buildings where the inside staircase and inside kitchen are without natural lighting. Key tasks in order to improve the lighting aspects are the use of the appropriate size of windows during refurbishment and solar PV system to help energy conservation in areas where artificial light is necessary during daylight.

• *Ventilation performance*

The buildings with 5 stories have natural ventilation for inner toilets and baths. In most cases, it is inadequate. Smell and vapor remain in the building. When using airtight windows, mold occurrence is common. The buildings with 11 or more stories have electric fans to ventilate the bathrooms and toilets, usually in bad conditions or broken. Usually the solution was using one big ventilation fan on the top floor, added to the flat roof. Bad design caused noise problems, so the tenants (who live near the fans) used to switch it off.

The key tasks in order to improve ventilation performance are:

- Using appropriate proposed heat-recovery ventilation system integrated strategy with energy-conservation refurbishment;
- Using special ventilated windows in the kitchens, regarding to gas-cookers and small areas;
- Using time-switchers for dark areas;
- Using electric dryers as communal facilities, to help reduce moisture content of flats;
- Light selves in staircases, and communal areas;
- Using the future stored energy for the lighting of common areas without natural lighting.

• *Acoustic building model performance*

Acoustic problems are very common in these types of buildings. The outside area is usually noisy due to the traffic noise of the huge boulevards. In some areas, not only the traffic of the local people and public

transport exist, but transit through the traffic as well. The inner noise is common too. The noise from the elevator, from the shafts and staircases are usual. The floor slab also have no sound-insulation and due to lack of insulation the flats are noisy. Dwellings are positioned from one side facing the boulevard (outside area of the block) and from the other facing the interior block courtyard. The flats orientated to the outside need acoustic refurbishment. In order to reduce the noise problem it is necessary to improve the windows and balcony doors to reduce the outside noise. Green façades could help to reduce the outside noise from traffic. To reduce the noise from the flat above, sound-insulation is necessary as an under-layer of the new floor coverings.

• *Thermal properties of the façade*

The new law on energy efficiency in buildings requires the certification of the existing buildings in accordance with the requirements of comfort and minimum energy efficiency. It has been effective in Serbia since September 2011, and defines that each building (new or existing) should have its own Energy Certificate²⁴. Considering the current situation of poor living conditions there is a need for research on the rehabilitation of buildings. The most applied façade system are parapet structures. The longitudinal façades consist of rows of parapets and windows with the surface of 70% of the façade and loggias that make 30% of the façade (Figure 112). The average annual heating energy consumption in the most of the housing buildings in Beograd is significantly higher, even 2 to 3 times more than in new buildings.

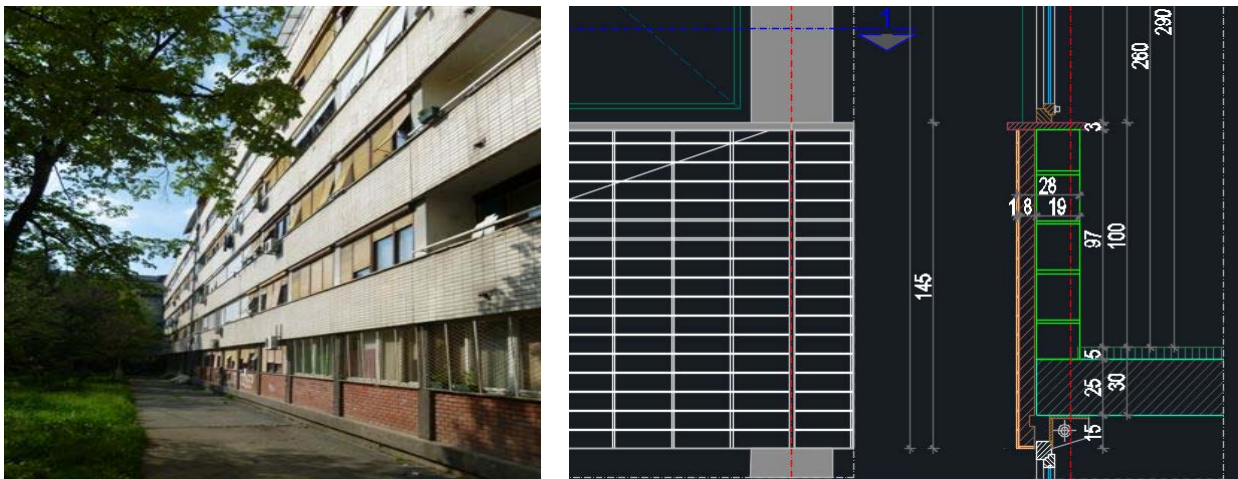

Figure 112: Balcony and parapet structure (see: Appendix - Block No.21 : Meander building)

The main problem is heating. It requires special attention for at least two reasons: the cost of energy, which places a heavy burden on the households and energy efficiency²⁵ in the context of the sustainable development of the country. The households built in the seventies and eighties, during the period of the most intensive housing stock growth, are characterized with the excessive final energy demand and

²⁴ PRAVILNIK : O USLOVIMA, SADRŽINI I NAČINU IZDAVANJA SERTIFIKATA O ENERGETSKIM SVOJSTVIMA ZGRADA <http://www.kombeg.org.rs/Slike/UdrGradjevinarstvo/Statika/Informacije-zakoni/EnergetskaEfik.pdf>, ("Sl. glasnik RS", br. 61/2011

²⁵ EU assessment: "Compared to other countries in Western and Eastern Europe, Serbia has one of the lowest energy efficiency ratings".

heating energy consumption growth. The prefabricated façade elements (panels and parapets) are in poor condition due to the intense process of deterioration and lack of maintenance (Laban, 2006).

The parapet elements, loggia and balcony structures (systems based on industrialized components and components assemblies (Figure 112)) are analyzed from technical and environmental aspects to evaluate the transformation capacity for the **building's envelope optimization and energy efficiency, natural and mixed ventilation optimal control, as well as PV systems integration.**

The dependency conditions between façade components are analyzed more specifically. Measures of improvement of energy performance in buildings will be achieved by refurbishment strategies of the building envelope. The building envelope as independent technical level can be modified without disturbing the other systems in the building model by: increasing the thickness of thermal insulation, including thermal bridges brake, complete replacement of the windows with improved thermal and solar features, and glazing of loggias. Façade parapets in most of the industrialized housing buildings are three-layer components composed of interior concrete or brick layer, isolation layer and exterior concrete layer, finished in ceramic tiles.

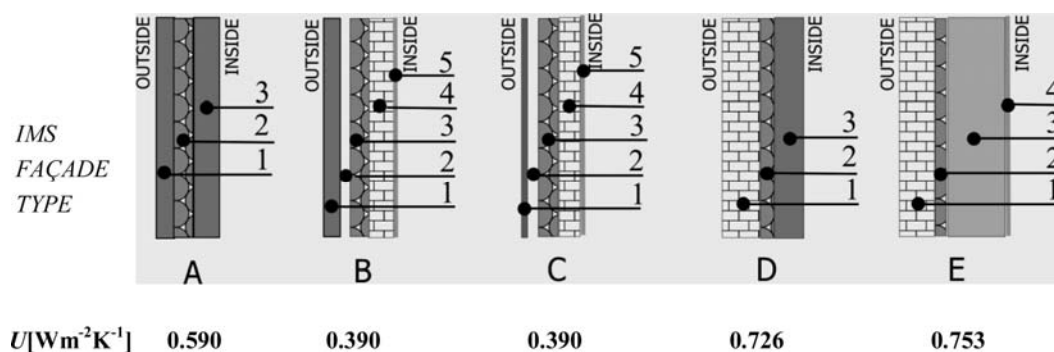

Figure 113: Variations of façade solution in the IMS buildings: Thermal conditions (Laban & Folić, 2012). **A:** Prefabricated panel and parapet: 1. Concrete 6 cm; 2. EPS (expanded polystyrene) 6 cm, 3. Concrete 8 cm; **B:** Semi-prefabricated ventilated façade: 1. Prefabricated concrete casing 6 cm; 2. Layer of air 2 cm; 3. EPS 6 cm; 4. Brick 6.5 cm; 5. Compo mortar 1.5 cm; **C:** Lightweight ventilated façade: 1. Asbestos cement sheeting 1 cm; 2. Layer of air 2 cm; 3. EPS 6 cm; 4. Brick 6.5 cm; 5. Compo mortar 1.5 cm; **D:** Semi-prefabricated façade with face brick casing: 1. Perforated face bricks 12 cm; 2. EPS 4 cm; 3. Reinforced concrete 8 cm; **E:** Traditionally built façade: 1. Perforated face bricks 12 cm; 2. EPS 2 cm; 3. Perforated concrete block 20 cm; 4. Compo mortar 1.5 cm.

The main problems of these buildings are joints between different components (parapet-column, column - window, window-parapet, etc.). This joints adversely affect the building's thermal performance and the years of poor maintenance additionally extend the damage to the joints. In some cases panels were supported with various clay based plates, which improved the thermal protection of the façades. The joints like parapet - slab, parapet - column, column-window are cold bridges. Within the same building,

prefabricated parapets are mostly of the same structure (Figure 113, A) with U-value of 0.59 W/m²K. The dwelling windows components are obsolete at a much higher level compared to the parapet wall elements.

7.3.5 Envelope system and dwelling comfort

We have made a detailed analysis of the Meander building envelope and its envelope as a representative example of the industrialized housing of post-war residential architecture.

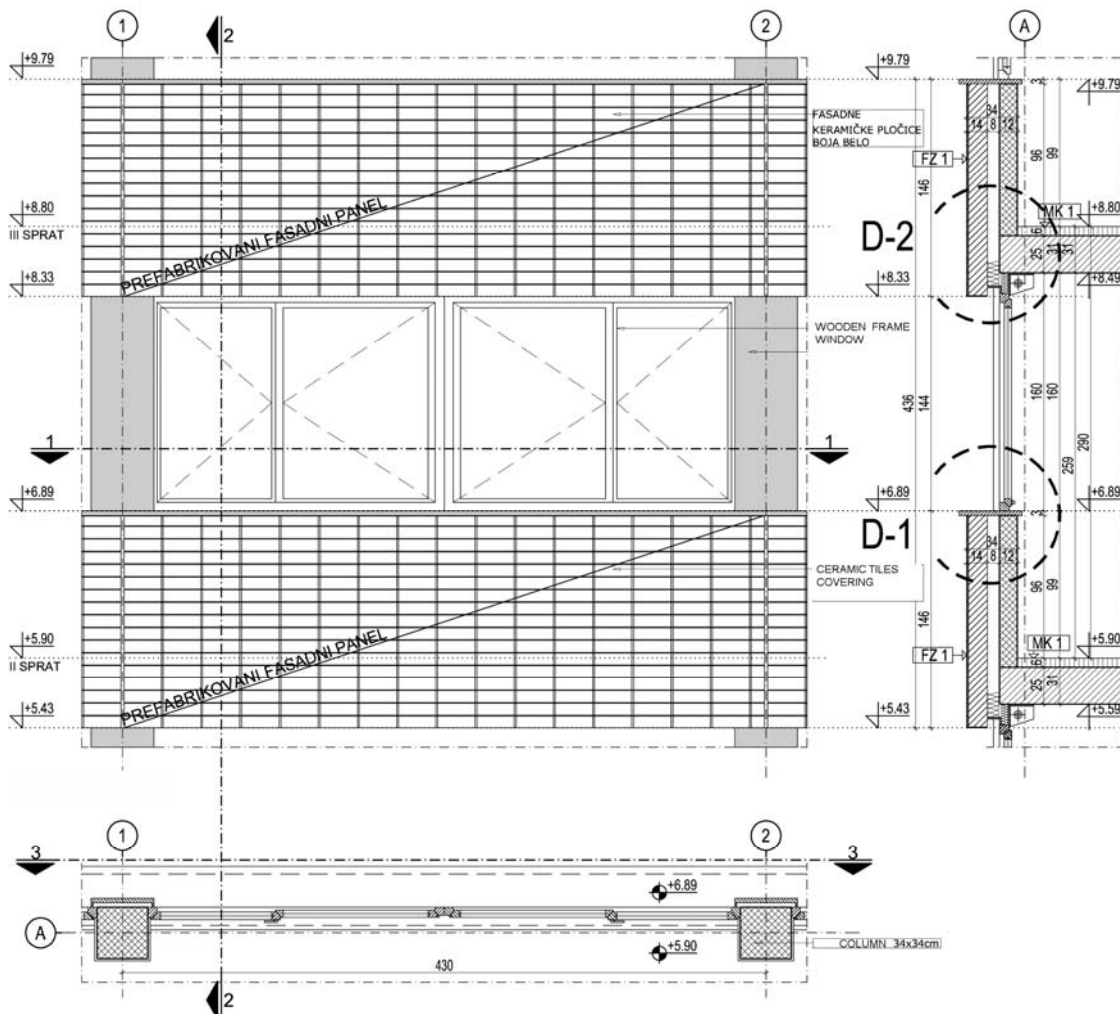

Figure 114: Detail of the parapet façade (vertical and horizontal section)- see: Appendix - Block No.21 : Meander building,

The façade parapets are three-layer components (internal brick 12.0 cm or 8.0 cm concrete layer for prefabricated components; thermal insulation (or air layer) 8.0 cm, external concrete 8.0 cm with the external finishing in ceramic tiles (Figure 114). Corresponding U - value is $U = 1,70 \text{ W/m}^2\text{K}$ (Table 5). Thermal bridges with exceeding allowed U-value of the external wall about $U = 1,034 \text{ W/m}^2\text{K}$ (the limit value is $0,4 \text{ W/m}^2\text{K}$ for Belgrade second climatic zone) are detected along the upper and bottom parapet edge (parapet - window edge and parapet - floor slab edge, respectively). Speaking in terms of thermodynamics, the windows are to be mentioned as the problem for both: size and inappropriate

thermal characteristics ($U > 3,0 \text{ W/m}^2\text{K}$) as well as the presence of the air infiltration. The windows are box type wooden frames, glazed with float glass of 4mm thickness with internal cloth blinds.

Different elements that composed the façade of building 'Meander' are presented with corresponding U-values in Table 5. According to *Appendix - Energy needs for heating: Parapet façade* it was calculated how the improvement of the envelope components (windows, parapets, floors above not-heated spaces, roof above heated space) influence the dwellings' living conditions. Finally, it has been simulated the heat losses/gains according to the improvement of all elements with the U value above the $0.92 \text{ (W/m}^2\text{K)}$.

HEAT TRANSMISSION COEFFICIENT

CLIMATIC ZONE	II
Outdoor air temperature is	$t_o = -18^\circ\text{C}$
Outdoor design temperature	$T_e = -12.1^\circ\text{C}$
Indoor air temperature is $T_i = +20^\circ\text{C}$	$T_i = +20^\circ\text{C}$
U (max) - value for existing buildings	$U = 0,4 \text{ W/m}^2\text{K}$

No.	Enclosing element		A / (m ²)	U (W/m ² K)	Fx	Q (W)
1	Outdoor window	OWin	1570.1	3.05	1.0	4788.8
2	Outdoor wall	OW	2774.2	1.70	1.0	4716.1
3	Basement floor slab	BFs	916.8	0.37	0.5	169.6
4	Ground floor slab	E	470.5	1.15	1.0	541.1
5	Flat roof above heat space	RC 1	811.9	0.71	1.0	576.4
6	Flat roof above heat space 1	RC2	575.4	1.93	1.0	1110.5

Table 5: U value of different envelope elements

1. Energy Consumption

According to the calculations²⁶ regarding the energy consumption for heating for the period from 15th October to 15th April, it is shown that the average annual energy consumption for space heating is $136 \text{ kw/m}^2\text{a}$ for lamella 4. As the central lamella is the subject of analysis, it can be considered that comparing to final lamellas 20% less energy losses are present. The high values for the heating needs in December, January and February are mainly responsible for the high heating energy needs per year. The heating energy needs per month with final $Q_{h,nd}$ value of $820125.3 \text{ kWh/year}$ and corresponding value per m^2 of 136.56 kWh/m^2 (Figure 115). According to the energy passport ranking this housing model belong to low E range. Most of the industrialized housing are E buildings according to energy efficiency.

²⁶ Appendix - Energy needs for heating: Parapet façade (The program used in the calculations is from Professor Aran, Faculty of Civil Engineering, University of Belgrade)

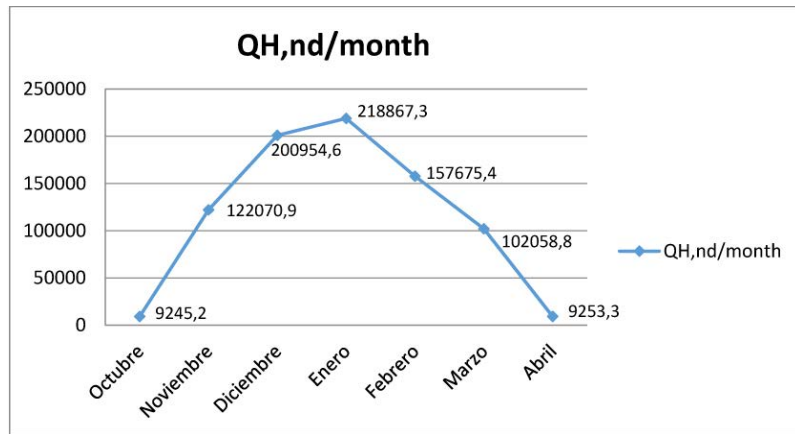

Figure 115: Energy needs for heating per month: current situation

The calculations per month (Figure 116) reveal that a very great energy consumption is present. It means that considering building is energy-inefficient. The necessity of added thermal insulation is out of the question now. All the refurbishment must be based on a well-designed outer thermal insulation.

POTREBNA ENERGIJA ZA GREJANJE Q H,nd (kWh/mesec)
(ENERGY NEEDS FOR HEATING - PER MONTH)
Tabela po mesecima:

MESEC	QH,ht	Qsol,gl	Qsol,c	Qsol	Qlj	Qel	Qint	QH,gn	QH,nd
Okt.	40457.5	21246.0	2486.2	23732.3	1556.7	5923.4	7480.1	31212.4	9245.2
Nov.	177348.1	32896.7	3680.2	36576.9	3891.7	14808.6	18700.3	55277.2	122070.9
Dec.	249118.6	25951.5	2888.9	28840.4	4021.4	15302.2	19323.6	48164.1	200954.6
Jan.	273457.8	31723.7	3543.1	35266.9	4021.4	15302.2	19323.6	54590.5	218867.3
Feb.	219837.7	40087.9	4620.9	44708.8	3632.2	13821.3	17453.6	62162.3	157675.4
Mart	181827.9	54052.0	6393.6	60445.6	4021.4	15302.2	19323.6	79769.2	102058.8
Apr.	41566.0	22102.2	2730.4	24832.6	1556.7	5923.4	7480.1	32312.7	9253.3

Mesečni gubici kWh/m2 mesec/ENERGY LOOSES kWh/m2 per month

Oktobar	qH,nd =	1.54
Novembar	qH,nd =	20.33
Decembar	qH,nd =	33.46
Januar	qH,nd =	36.44
Februar	qH,nd =	26.25
Mart	qH,nd =	16.99
April	qH,nd =	1.54

Godisnja potrebna energija za grejanje qH,nd (kWh/m2a)
(ENERGY NEEDS FOR HEATING /year)
QH,an = 820125.3 / 6005.7 =136.56 (kWh/m2a)
QH,nd rel =136.56 / 70 = 195.08 %
Namena zgrade : Zgrada sa vise stanova
Energetski razred- **BUILDING ENERGY REAING: E**

Figure 116: Energy need/losses for heating per month and per m² of dwelling area (Appendix - Energy needs for heating: Parapet façade)

The new insulation layer must be added to decrease heat-losses and cold-bridges. It is advisable to use mineral-wool or glass-wool instead of foam insulation materials, regarding the fire-safety problems. The new materials can be proven too: flax, wool, cellulose could be good solutions after it has fire-checked.

A well designed outside insulation helps to control the thermal comfort in summer and winter (the surface temperature is higher, the comfort is better in winter). Summer cooling is a problem. Ventilation, shading and also the outside natural area support the comfort control. The outer thermal insulation on façades should be approved by 10 cm as a minimum. Good insulation on a flat roof with 20 cm as minimum. A green roof is advisable to help summer comfort. The specially designed new windows, three layers of glasses for north façades, and with shading devices for the south will balance the inner temperature.



Figure 117: A different solution for the IMS building model: TV Building Block No. 28

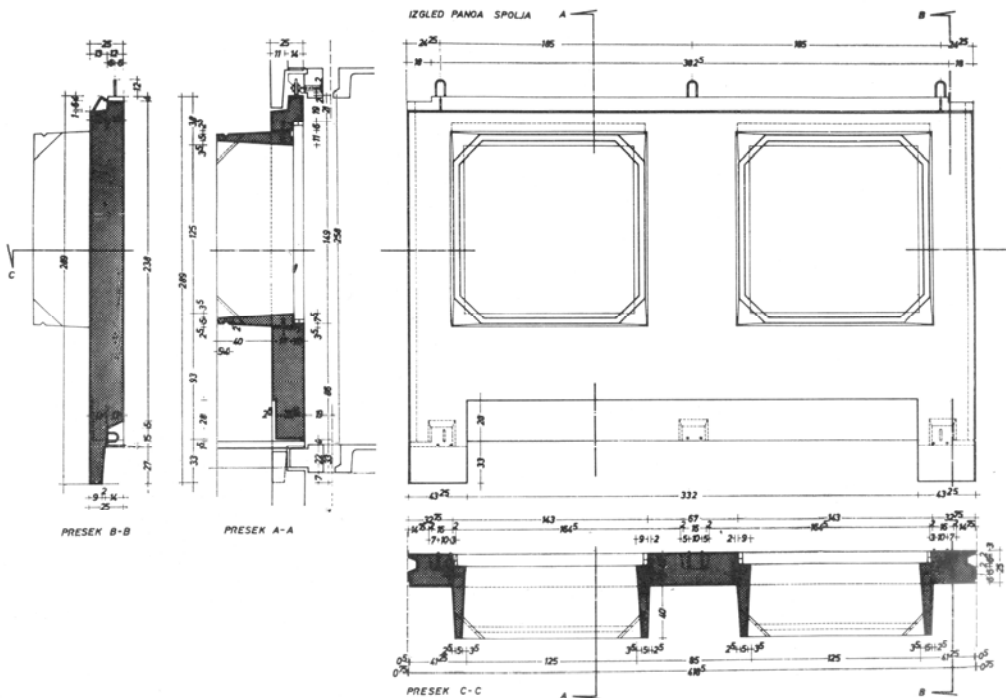

Figure 118: Industrialized prefabricated "Keramzit" panel (Koprivica, 1970)

In 1967, a new material ceramsite ('Keramzit') concrete was applied for fabrication of light concrete façade panels (Figure 118, Figure 119). 'Keramzit' was used as an aggregate with good thermal properties for the fabrications of 'Keramzit' façade panel. According to the calculations, a 25,5 cm thick panel had been set up. 'Keramzit' concrete is lightweight aggregate concrete. It also, provides strength and

mechanical properties such as crack resistance like ordinary concrete and, therefore, as green building materials, it has a wider application prospect (Yingying & Beisi, 2011). The panels were fabricated in an industry plant with steel plates preinstalled in the panel for the connections and cladding. 'Keramzit' panels are not load-bearing panels applied for the enclosing of a building load-bearing structure. The 'Keramzit' panel was applied for the housing in Block No.28, for two longitudinal buildings noun as TV building built in IMS system (Figure 117).

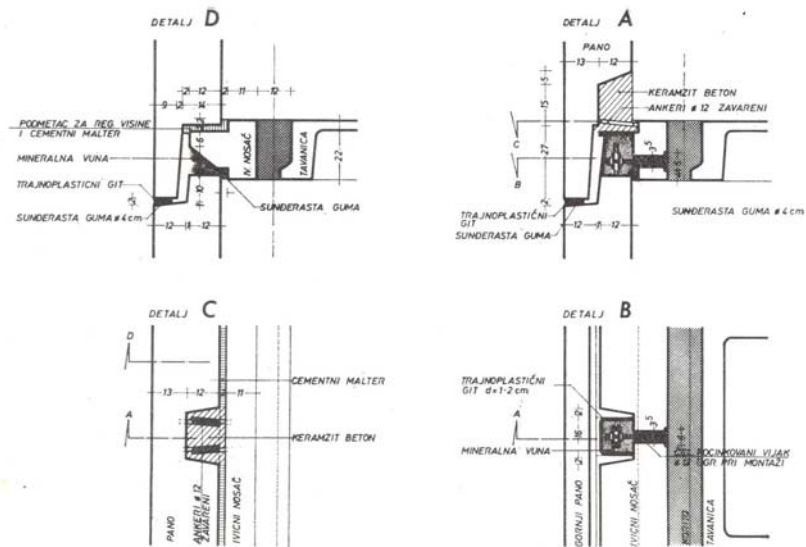

Figure 119: Technology of joints: a detail of joint between “Keramzit” panel and an edge girder (Koprivica, 1970)

8 Integrated refurbishment strategies for industrialized housing

8.1 Massive Housing retrofit technologies

Retrofit technologies are energy conservation measures (ECMs) used to promote building energy efficiency and sustainability. Retrofit technologies range from the use of energy efficient equipment, advanced controls and renewable energy systems to the changes of energy consumption patterns, and the application of advanced heating and cooling technologies. Retrofit measures should be considered in their order of economic payback, complexity and ease of implementation.

8.1.1 Energy efficiency renovations

The retrofitting of massive housing stock is a priority for Europe and developed countries. It is important to know which are the criteria currently used for assessing energy-efficiency measures and the approaches that driving the assessment of energy - efficiency measures. In recent years have been analyzed the potential for renovating existing housing stock in terms of energy savings and reducing CO₂ emissions. The construction sector plays a key role in global sustainable development. Strategies to make buildings more sustainable rely mostly on life cycle approaches for different building parts, covering the three main aspects of sustainability: environmental, economic, and social (Gervásio, Santos, Martins, & Simões da Silva, 2014). The use of such an approach for the housing refurbishment has been identified as a decisive tool in the pursuit of sustainable construction.

The aim of this chapter is to review, analyze, and compare the methods and tools that are currently used to evaluate housing building retrofits (i.e. energy assessment, life cycle assessment, life cycle cost, multi-criteria optimization methods, etc), as well as to provide an overview of the main energy-efficient measures applied.

Industrialized residential architecture of the post-war period is undergoing the process of refurbishment in two ways:

1 - Retrofitting of massive housing by improving energy efficiency

2 - Techniques of adaptations of the building structure for post-war massive housing

1) Retrofitting of massive housing by improving energy efficiency

Energy efficiency measures are categorized in the retrofitting of the building envelope, improvement of the building service systems and implementation of renewable energy. The research covers various energy savings measures, works developing assessment methodologies for housing renovation, and research for energy saving and reducing CO₂ emission in the existing housing stock. According to Energy Efficiency in Buildings in the Contracting Parties of the Energy Community (Final reports,

24/02/2012)²⁷ (L. Tchervilov & G. Kaloyanov, 2012) the best practice technologies in connection to housing retrofits and energy efficient renovation are: i) high envelope performance (insulations of façades, roofs, top ceilings, ground floors, double glazing windows with PVC frame; renovation of balconies and entrances); ii) air-tight constructions; iii) double façades and glazed areas; iv) heat recovery ventilation system; v) condensing boiler; vi) district heating systems with low losses; vii) improving heating systems (combined heat and power, insulation of distribution pipes); viii) heat pumps; ix) natural, hybrid and PV-assisted ventilation; x) solar (domestic hot water) DHW heating system; solar wall and air collectors; PV- installations, etc.

In Radomir 2 (Bulgaria), a massive housing block, 47 % of energy saving has been achieved – building has been improved with a longer life span, better living comfort, less energy consumption. Major rehabilitation measures are presented in Figure 120, for a building envelope performance and upgrading of the installations' systems and services. The isolations of the building envelope (roof, basement ceiling, the external concrete walls) and replaced windows are the main retrofitting measures.

	State-of-the-art	
	Before renovation	After renovation
	Constructions [U-values: W/m²K] <ul style="list-style-type: none"> • Roof [0,9] • Non-insulated basement [2,9] • Non-insulated external concrete walls [2,95] • Double glazed wooden windows [2,9] 	Constructions [U-values: W/m²K] <ul style="list-style-type: none"> • Additional insulation of roof [0,5] • Insulation of basement ceiling [0,52] • Insulation of external concrete walls [0,52] • New PVC windows [1,8]
	Installations <ul style="list-style-type: none"> • No boiler • No control of the heating system • No control of radiators 	Installations <ul style="list-style-type: none"> • Installation of new efficient boiler for central heating • Presetting heat radiation; optimum adjustment of the heating curve with weather-dependent flow temperature regulation • Fixing of thermostatic valves, timer-controls and heat meters on radiators

Figure 120: Radomir 2 massive housing block (Bulgaria): Before and after renovation

	State-of-the-art	
	Before renovation	After renovation
	Constructions [U-values: W/m²K] <ul style="list-style-type: none"> • Outside walls [1.20] • Roof [0.90] • Cellar ceiling [0.70] • Windows [2.50] 	Constructions [U-values: W/m²K] <ul style="list-style-type: none"> • Outside walls [0.08] • Roof [0.09] • Cellar ceiling [0.21] • Triple glazing of windows [0.86]
	Installations <ul style="list-style-type: none"> • Gas boiler 	Installations <ul style="list-style-type: none"> • District heating • Mechanical ventilation with heat recovery for each room

Figure 121: Linz (Austria): Integrated refurbishment scenario

Linz (Austria) massive housing achieved 91 % of energy saving, total living expenses lower than before renovation. The passive house standard was achieved by a very high insulation of the outside

²⁷Energy Efficiency in Buildings in the Contracting Parties of the Energy Community <http://ei-education.aarch.dk>

walls by using a so-called "GAP-solar-façade". Insulation of floors and roof as well as triple glazing of windows was applied.

In each room a mechanical ventilation system with heat recovery was installed. The energy performance indicator was cut from 179 to 13.3 kWh/m², which is equal to an energy saving of 91 %. Special features of refurbishment measures are: i) prefabricated façade elements with built-in windows and ducting for controlled ventilation were developed; ii) a solar honeycomb façade was employed; iii) the balconies were enclosed, which increased the usable living area; iv) renovation was carried out without much inconvenience for the occupants.

2) Techniques of adaptations of the building structure for post-war massive housing

In most European countries refurbishment techniques have been applied for the housing building structure in relation to the different building parts. The set of operation strategies for regeneration of the buildings depends on the composition and relations between the components in the building model. According to the Cost Action C16 (Braganca, L., Wetzel, C., Buhagiar, V., Verhoef, 2007), the techniques of adaptations of the building structure include: i) how to build extra floors onto existing buildings; ii) installation of elevators; iii) changing of the load-bearing elements where possible; iv) merging flats; etc. (*see: Appendix - Refurbishment scenarios for post-war housing in Europe: State-of-the-art*).

8.1.2 Integrated Refurbishment Scenario

Integrated refurbishment scenarios are different retrofit technologies suitable for total building refurbishment. Integrated refurbishment scenario consists of methods, tools, techniques, energy-efficient measures, renewable energy technologies for housing retrofitting (Figure 122). It will be applied for the technical, functional and energy efficiency refurbishment of the industrialized housing. For example: an enlargement of the dwelling area and energy-efficient systems will be integrated in the façade refurbishment scenario. The Linz case study is an example of integration of various measures in the "GAP-solar-façade" refurbishment scenario (Figure 121).

"The retrofit technologies are energy conservation measures (ECMs)" (Ma, Cooper, Daly, & Ledo, 2012) used to promote building energy efficiency and sustainability (Figure 122). Retrofit technologies range from the use of energy efficient equipment, advanced controls and renewable energy systems to the changes of energy consumption patterns, and the application of advanced heating and cooling

technologies. Retrofit measures should be considered in their order of economic payback, complexity and ease of implementation²⁸.

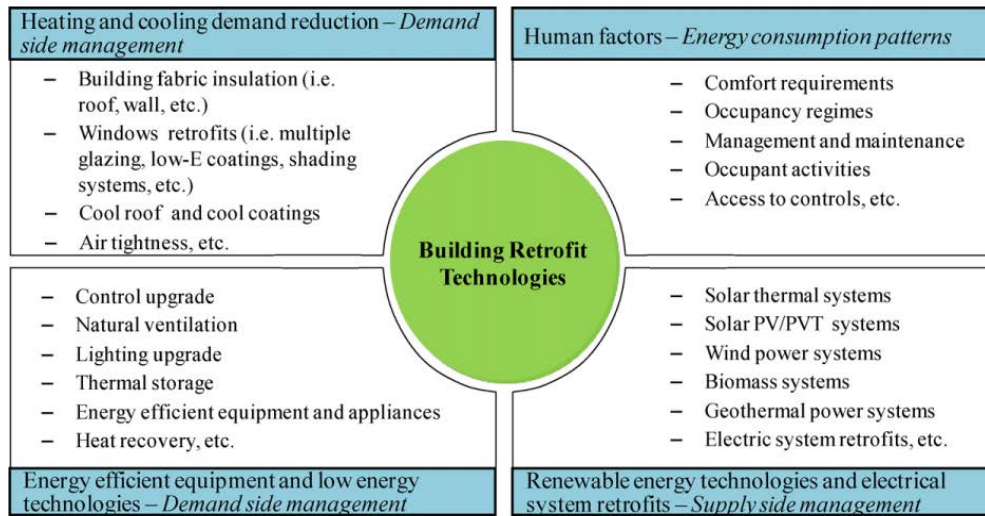

Figure 122: Main categories of building retrofit technologies (Ma et al., 2012)

➤ Energy Hubs

The energy-efficient measures have been integrated in the new 'energy hubs'. 'Energy hubs' are energy saving components in buildings. The energy hub is a central point in a district where all energy distribution systems meet each other and energy flows can be converted. Vehicles can be refueled with (bio)gas or liquid bio-fuel there, for example. (Bio)gas can be used for combined heat and power systems in order to generate heat and electricity (Fay et al., 2000).

The Dutch project 'Transition in Energy and Process for a Sustainable District Development' focuses on the transition to sustainable, energy 'neutral residential districts' in 2050, particularly in energy concepts and decision processes (Willems, Jablonska, Ruijg, & Krikke, 2011). The degree of energy neutrality is defined as the renewable energy generated in a district, divided by the energy demand of that district. If the degree of energy neutrality is higher than 100%, this means that the district can export energy surplus. Values under 100% mean that the district needs to import renewable (or fossil) energy in order to meet its energy demand (Jablonska, Epema, Willems, & Visser, 2010).

Three concepts are based on the idea of an energy hub smart district heating, cooling and electricity networks, in which generation, storage, conversion and exchange of energy are all incorporated: the geo hub (using waste heat and/or geothermal energy), the bio hub (using waste heat and/or biomass) and the solar hub (using only solar energy). The fourth concept is the so-called all-electric concept, based predominantly on heat pumps, PV and conversion of high temperature heat from vacuum collectors to electricity (Jablonska et al., 2010). Jablonska's calculations show that by implementing the hub concepts, the energy neutrality in 2050 ranges from 130 % (solar hubs) to 164% (geo hubs). With the all-electric

²⁸ CIBSE, Energy Efficiency in Buildings: CIBSE Guide F, Chartered Institution of Building Services Engineers, London, 2004.

concept, an energy neutrality of 157% can be reached. This means that will be produces more energy than its needed (30 % , 64% and 57 % respectively). This innovative and integral systems will be applied for renovation and new housing and applied for entire districts. Each districts will be supplied with the sustainable energy generated within the boundaries of the district.

• ***Integrated Refurbishment Scenarios for Building model (BM): European cases***

A choice of priorities and the most suitable operating technologies for massive housing, constructed using heavy prefab systems and procedures targeted at the fast and low-cost satisfaction of the demand, rather than at the quality of the dwelling space, imposing priorities to focus on improving factors such as the functionality of the residential units, the energy efficiency of the buildings and the architectural quality of the buildings. The main operating strategies have been applied through: i) upgrading functionality, transformation of the layout by resizing of the residential units; ii) structural additions to existing buildings involving the development of new volumes; iii) load-bearing control and improving safety; iv) experimental reuse and regeneration work involving the recycling of the replaced components.

Innovative trends in terms of building methods and techniques used in modification, re-strengthening or adaptation of the structure affect the building envelope components and building functional organization.

The listed examples in the *Appendix - Refurbishment scenarios for post-war housing in Europe: State-of-the-art* contain regeneration practices for different countries, relative to the technology and techniques used for the various transformations of the structural components and systems.

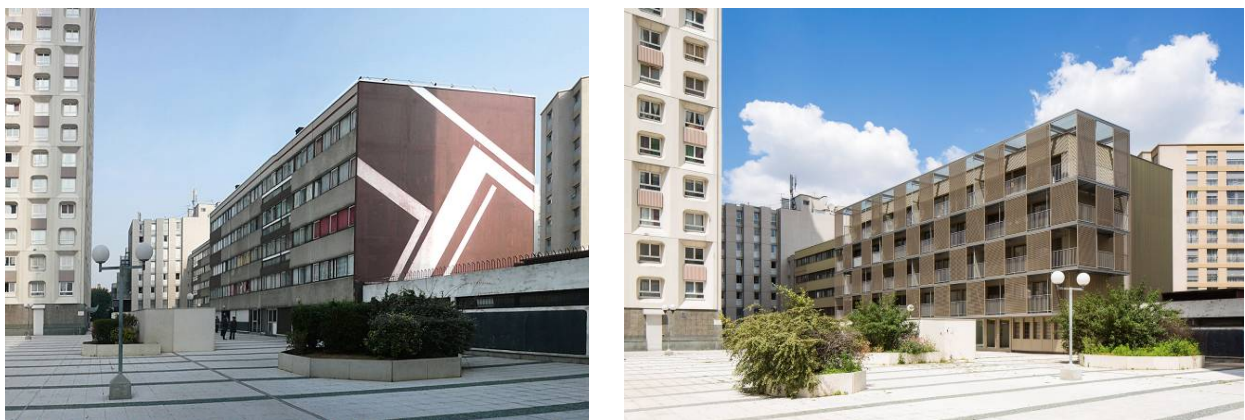

Figure 123: Annex of balconies and thermal refurbishment of the envelope ("Square Vitruve" social housing, see: Appendix - Refurbishment scenarios for post-war housing in Europe: State-of-the-art).

Rehabilitation of the 'Square Vitruvie' housing building was realized with façade refurbishment scenario. On the existing façade, balconies had been added to extend the living space of dwellings (Figure 123). With the new balconies the sun shading was approved as well as the thermal properties of the existing

façade. All this refurbishment strategies were put together into the design of the integrated system for the new skin. A 'kit' of components was used to find different purposes for the new skin. This skin was installed without putting machinery on the concrete slab and using no cranes or pods. The balconies are suspended from the roof, and all the materials and technical solutions have been designed to avoid overloading the existing structure and with minimum disrupting of the residents' daily life.

The existing three-storey block in Praunheim, a district of Frankfurt am Main, is a typical residential development of the 1960'. Prefabricated light steel systems for walls and floors and dry construction process have been applied to the roof extension with 12 new apartments built as part of the rehabilitation project (Figure 124).



Figure 124: Annex of attics on the top of the flat roofs: Three-storey block in Praunheim, a district of Frankfurt am Main(T S B Consulting, 2007), see: Appendix - Refurbishment scenarios for post-war housing in Europe: State-of-the-art

During the main action of the building extension, a complete set of integrated rehabilitation strategies was applied to total refurbishment of the existing buildings: i) upgrading of the electric current lines; ii) installation of a new electric meter; iii) new doors in the flats; iv) renewal of the staircases; v) fire protection requirements (e.g. fire door in the cellar); vi) new paintings of the façade; vii) addition of new balconies; viii) rehabilitation of the existing loggia; ix) water tap in the backyards; x) renewal of the entrances. Prefabricated light steel systems for walls and floors and dry construction process have been applied to the roof extension. During the main action of building extension the complete set of integrated strategies were applied for the total refurbishment of the existing buildings (see: Appendix - Refurbishment scenarios for post-war housing in Europe: State-of-the-art)

In the residential area of Markbacken in Örebro, Sweden (3-4-storey slab blocks)²⁹ the integrated refurbishment scenario was directed towards solving technical problems due to the ageing of materials and new demands for energy efficiency. Three principally different solutions were used, due to different

²⁹Improving the Quality of Existing Urban Building Envelopes – State of the Art. M.T. Andeweg, S. Brunoro, L.G.W. Verhoef (eds.) IOS Press, 2007. © 2007 IOS Press and the Authors

technical and design prerequisites: i) enlarging balconies and adding new balconies; ii) merging flats at the bottom floor and first floor (Figure 125, a, b); iii) rebuilding and enlarging of the passages; iv) adding a lift and adding the new entrances. The additional balcony slab is born by two steel bars, fastened to the old balcony slab. The light fitting on the side walls of the balconies are fastened on similar steel profiles (Figure 125c).

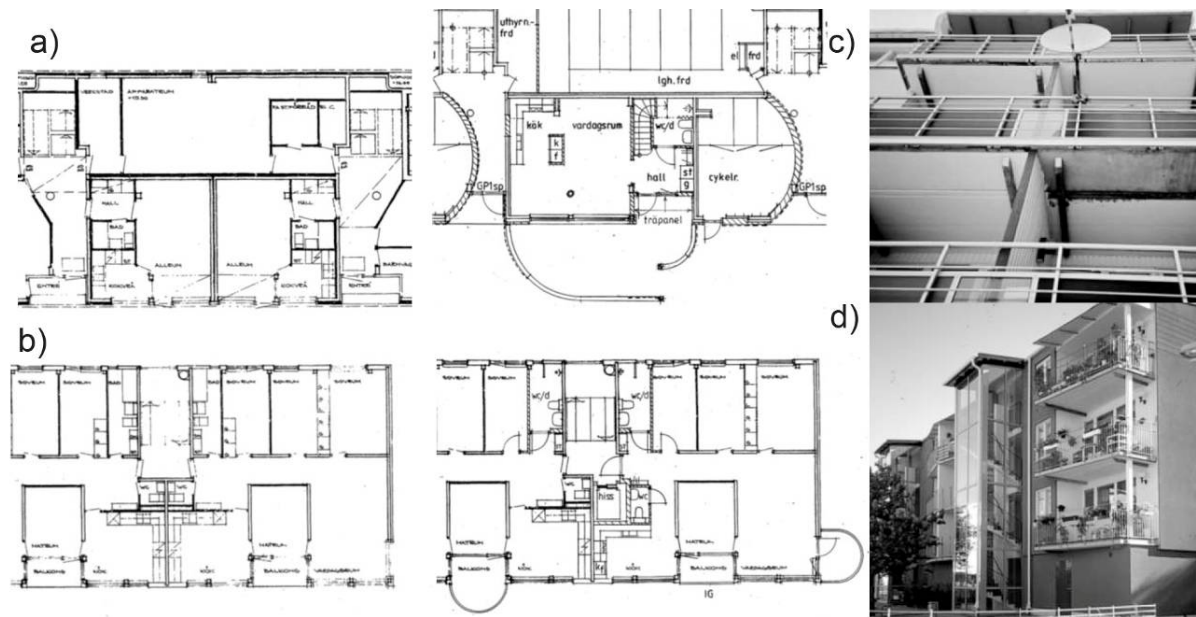
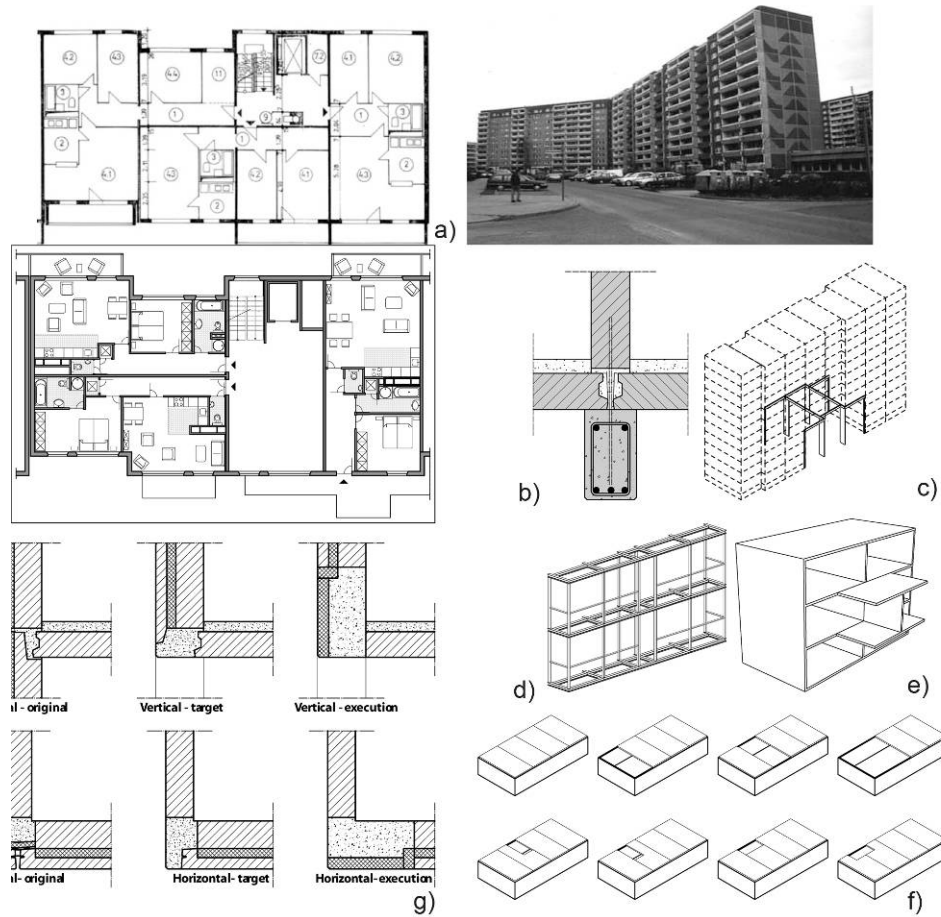

Figure 125: Residential area of Markbacken in Örebro, Sweden: a) The bottom floor before and after merging the flats; b) the floor plan before and after the addition of a lift; c) enlarging the balconies; d) The addition of staircases. (see: Appendix - Refurbishment scenarios for post-war housing in Europe: State-of-the-art)

The Franz-Stenzer Building Block - Marzahn, Berlin, 62.000 housing units built between 1975 and 1991, was constructed with WBS 70 large concrete panel system. The building was built completely 'in the system'. A complete interior redesign as well as a totally new façade are achieved (Figure 126). The new catalog of components are designed to be used in the transformations of WBS 70 blocks. The poor flexibility of the prefab structures made from large bearing panels led to experimentation with complex structural solutions, which permitted radical transformations of the façades, reducing the quantity of the load-bearing panels. Another problem faced during the functional upgrading projects was the improvement of facilities for the disabled and the elderly. The refurbishment scenario consists of the next solutions: i) enlarging balconies and adding new balconies (Figure 126 d, e); ii) merging of two flats for the duplex (Figure 126, f); iii) rebuilding and enlarging passages (Figure 126, b, c).

Figure 126: The Franz-Stenzer Building Block - Marzahn, Berlin: a) new floor plans vs. old; b) a construction principle for making a breakthrough; c) removing the bearing façade elements (horizontal and vertical sections); d) a steel

construction for four winter gardens; e) a principle of concrete extension; f) removing (parts of) floor elements; g) execution varieties of breakthroughs in the load-bearing façade elements³⁰



➤ Interface design for more transformation capacity of industrialized systems

The interface design is a new research objective to reach more flexible and simple connections for the new systems and components to be installed on the existing buildings. Habraken, the founder of 'Open Building' aimed to divide a construction into several systems and sub-systems that can be “changed or removed with a minimum of interface problems” (John Habraken, 2008). The different levels of the building and its' components are connected with each other by means of *interfaces*. If flexibility is to be achieved, the interfaces have to be demountable. A research published by Durmisevic proposed a classification of seven different types of connections, ordered from fixed to flexible. Figure 127 shows the different principles behind these seven connections (Durmisevic, 2006). For the existing housing refurbishment scenarios the integration of the new systems and components in the Building Model (BM) should be based on the simple and demountable connections. The most suitable connection for the

³⁰ Vogdt, F.U.; Preservation and Modernization of Industrially Constructed Residential Buildings

integrated approach of the new retrofitting components is indirect connection with additional fixing device (Figure 127).













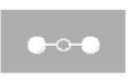

	type of connection	graphic representation	dependence in assembly
fixed	 I Direct chemical connection two elements are permanently fixed (no reuse, no recycling)		$m1 \text{---} e12$
	 II direct connections between two pre-made components two elements are dependent in assembly/disassembly (no component reuse)		$e11 \rightarrow e12$
	 III indirect connection with third chemical material two elements are connected permanently with third material (no reuse, no recycling)		$e11 \xrightarrow{m1} e12$
	 IV direct connections with additional fixing devices two elements are connected with accessory which can be replaced. If one element has to be removed than whole connection needs to be dismantled		$e11 \begin{matrix} \nearrow c1 \\ \searrow e12 \end{matrix}$
	 V indirect connection via dependent third component two elements/components are separated with third element/component, but they have dependence in assembly (reuse is restricted)		$e11 \rightarrow c1 \rightarrow e12$
	 VI indirect connection via independent third component there is dependence in assembly/disassembly but all elements could be reused or recycled		$e11 \begin{matrix} \nearrow c1 \\ \searrow c2 \end{matrix} \rightarrow e12$
flexible	 VII indirect with additional fixing device with change of one element another stays untouched all elements could be reused or recycled		$e3 \rightarrow C \leftarrow e1$ $e2 \uparrow$

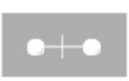
Figure 127: Seven principles of connections, ranged from fixed to flexible (Durmisevic, 2006)

➤ Infill Systems for housing refurbishment

'Infill' systems are all products and services for efficient and customized interior fit-out for housing refurbishment. The idea of 'infill' as movable part verify the feasibility of methodology for refurbishment of massive housing at the level of the individual dwelling. For the units spatial and functional adaptability, different 'infill' systems have been developed. Development of floor systems makes possible to treat 'infill' as a movable property. Key technology of the developed system is interface design between the 'infill' and load-bearing structure.

J. Habraken's Matrix Tile floor system (Figure 128) permits rapid and accurate piping installations and a maximum floor plan variety within dwelling space, with no interference with the spaces below because its use avoids floor penetrations except at the building's vertical pipe shafts. The applications include adaptive reuse of entire buildings, and transformations of dwellings without affecting the load-bearing system and building envelope.

The 'matrix tile' is a solid material (e.g. medium density polystyrene) applied on top of the floor slab. The tile thickness is approximately 4" (four inches)³¹. Grooves of various sizes are located in several

³¹ <http://infillsystemsus.com/matrix-tile-system>

horizontal 'zones' allowing the secure placement, without interference of lines or conduits for various services, such as hot and cold water lines, gray-water drain lines, heating pipes to radiators, floor heating, ventilation ducts, gas pipes, etc. The installed lines and conduits are covered by a 1” (one inch) fire proof floor layer. Metal stud partitions are erected on this floor and any floor finishing can be installed. The Matrix Tile System assures a maximum floor plan variety and allows individual occupants to meet floor plan layout preferences independently of the other units in the building.

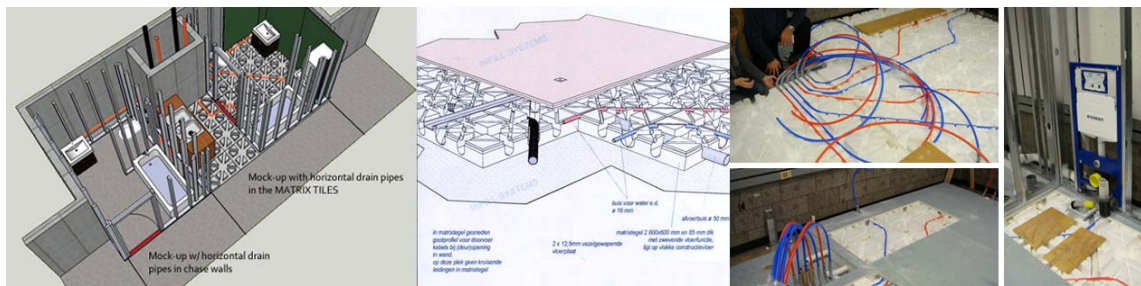

Figure 128: Matrix tile mockup and matrix tile system

In the University of Tokyo was developed double floor system that enables 'infill' modules to be treated as a movable property (Serizawa, 2005). A floor system by which kitchens and bathrooms can exchange the positions. The developed system can assume better transformations' options according to simple interface geometry (Figure 129).

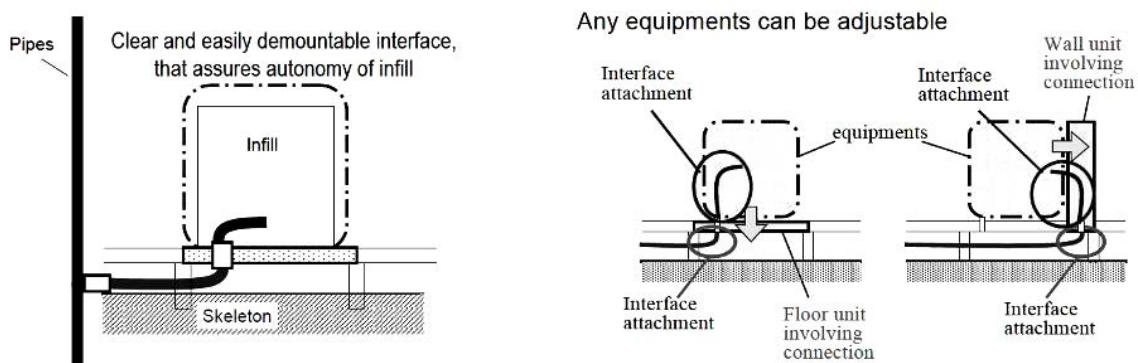

Figure 129: Composition using demountable interface (left); Attachment of demountable interface (right)

All changes of dwellings' interiors are realized by plug-in and plug-out installation of 'infill' elements. For the functional refurbishment of dwellings in massive housing, the 'infill' systems may be solution. Plumbing sleeve is developed in order to arrange properly the pipes below the raised floor. Using this sleeve, it becomes easier to connect firmly pipes to the infill box units (Figure 130). In the same way, it will be possible functional changes in the dwelling units.

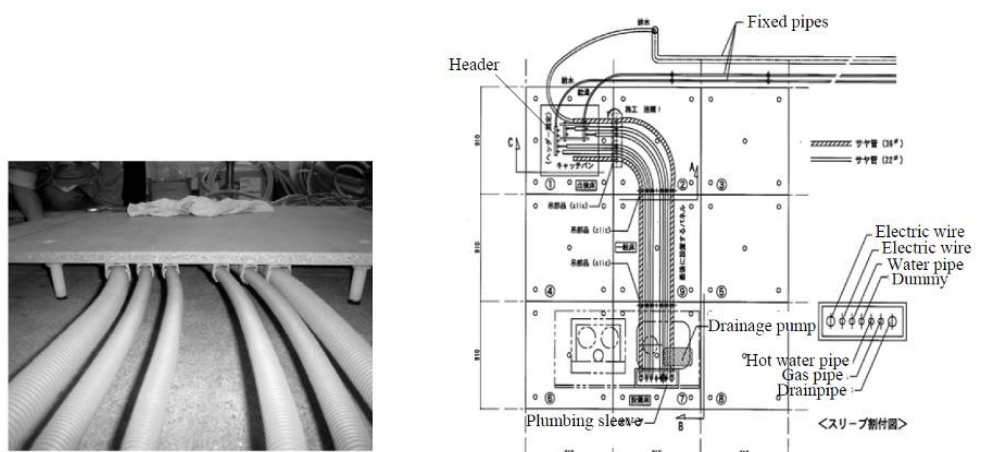

Figure 130: Hanged pipes on the floor - left; Plane of the floor panels and pipes - right, (Serizawa, 2005)

8.1.3 Current policy for industrialized housing refurbishment in Beograd

According to the Implementation Program of Energy Strategy it is estimated that average Serbian final energy consumption for heating and hot water in buildings is about 220 KWh/ m², which is highly above the EU average. The Building sector is the most energy-demanding sector in Serbia, representing approx. 44% of the total final energy consumption in 2008³². The households require 56% of the total electricity consumption in Serbia. 65% of the mentioned consumption is used for space heating in the residential sector (source SEEA). There is a large potential for energy saving and a wide scope of viable energy efficiency measures in the housing building stock.

A further methodological approach includes analyses of characteristics of both: the existing building and hypothetical improved models, and comparative analyses of obtained results. This approach could generally be applicable to building refurbishment, but generalization of technical solutions and possible benefits have to be carefully individually considered.

- *Building energy passport*

Implementation of energy efficient construction in Serbia is based on the building energy passport. Building energy passport contains information about building energy rating according to its energy properties. Buildings are classified in eight energy grades scaled from "A +" to "G", where "A +" indicates favorable energy, and "G" energetically non-favorable building. Building energy rating is determined on the basis of data on energy consumption for heating per year (QH,nd), calculated in accordance with the regulations governing the energy performance of the buildings. Energy rating for the existing buildings, following the guidance of the reconstruction, extension, renewal, modification, repair and energy rehabilitation, must be improved at least for one level.

An energetic control of the building include:

³² Future needs in the field of Rational Use of Energy in Serbia Bojan Kovačić, MSc. Professional Advisor, SUNP, Novi Pazar

- Analyzing the architectural - constructional characteristics of the building and the thermal performance of the building envelope;
- Analysis of the energy performance of heating systems;
- Analysis of the automatic control of heating systems in buildings.

Zgrade sa više stanova		nove	postojeće
Energetski razred	$Q_{H,nd,rel}$ [%]	$Q_{H,nd}$ [kWh/(m ² a)]	$Q_{H,nd}$ [kWh/(m ² a)]
A+	≤ 15	≤ 9	≤ 10
A	≤ 25	≤ 15	≤ 18
B	≤ 50	≤ 30	≤ 35
C	≤ 100	≤ 60	≤ 70
D	≤ 150	≤ 90	≤ 105
E	≤ 200	≤ 120	≤ 140
F	≤ 250	≤ 150	≤ 175
G	>250	>150	> 175

Figure 131: Building energy rating is an indication of the energy performance of the building (the last column are references for the existing buildings)³³

Building energy rating is expressed with the relative values of the annual final energy consumption for heating [%], and represents the percentage ratio of a specific year for heating $Q_{H,n,d}$ [kWh/(m²a)] and maximum allowable $Q_{H,n,d, max}$ [kWh / (m²a)] for a certain category of buildings (Figure 131).

8.2 Refurbishment scenarios for industrialized housing in Beograd

The refurbishment scenarios for the industrialized housing in Beograd consist of different measures to upgrade buildings at the functional, structural and environmental level. According to the graph model reports (GMR) the most suitable parts of the industrialized building model (BM) for transformations are the building envelope (façade and roof) and the building layout. The refurbishment scenarios may vary between different BM-s and are based on the improvement of the building envelope and dwellings' comfort. Important work should be the refurbishment of one building part with over all benefit for the total building upgrading.

The main operating strategies relative to the case studies collected and documented, include:

- **Upgrading functionality involving changes of the use, the transformation of the layout, resizing of the residential units, etc.**

The refurbishment work on the façades and bearing structure is part of the regeneration of the buildings' interiors. In these cases, the transformation of the building envelope consists of the adaptation of the skin according to the modifications of the layout. These modifications may consist of the creation of new openings in the façades in order to adapt to the new ventilation and lighting requirements imposed by the

³³ (Pravilnik o uslovima, sadržini i načinu izdavanja sertifikata o energetske svojstvima zgrade, 2011)

new layout of the interiors; the inclusion of new structural elements in order to make the accommodation more flexible; the development of new additional spaces achieved by extending balconies and loggias. Integrated refurbishment scenarios include the energy efficiency of the envelope, dwellings' comfort and functional changes.

- **Additions to existing buildings involving the development of new volumes**

Additions to the existing buildings are of particular interest. These interventions concern both the building envelope and dwellings' layout. In both cases, the partial demolition work and the subsequent insertion of the new sections of building will be carried out with industrialized procedures, which use technologically advanced building solutions.

The envelope refurbishment scenario is based on improving the building's energy performance with a possibility to make radical transformations to the architectural image. The additional advantages are connected with a substantial increase in the living space that can be created. Building of an extra storey on the existing housing blocks allows an average increase in dwelling units. Important work has been undertaken with annex of attics on the top of flat roof. With the roof refurbishment is achieved an overall benefit for the total building and were resolved the next mayor problems: i) flat roof water infiltration; ii) over-heating in summer, heat losses in winter; iii) comfort of the underneath dwellings.

Addition of bay windows, balconies and loggias, addition of an independent structure to increase the size of the flats; transformation of the envelope, all of this strategies may be used for functional changes in dwellings. Planning the enlargement of a dwelling unit and moving a façade line are possible according to modular extensions of the load-bearing structure in the IMS building models.

8.2.1 Refurbishment scenario: building envelope improvement

The building envelope improvement consists of measures aimed to improve energy performances of horizontal and vertical enclosing systems of the building envelope. The following simulations have been run considering the maintenance of the point value of the indoor air temperature (from 20C° in the rooms to 22C° in the bathrooms) providing satisfactory thermal comfort conditions through the heating period. The climatic conditions for territory of Beograd are taken into account for analyses and mathematical simulations of the model related to daily temperatures during the year, frequency of temperatures, frequency of solar radiation intensity, overcast frequency, wind speed frequency and its direction in winter, summer and transitional period. "Aran" software³⁴ is used for the simulation of the building energy performance. A simulation is much more effective when it's used for comparing the predicted performance of design alternatives, rather than when used to predict the performance of a single design

³⁴ Aran software from Belgrade University, Faculty of Civil Engineering

solution. For this reason the following models of improvement are created: model 1, model 2 and model 3 which are characterized by different energy performances.

Retrofitting measures which are considered as the most suitable for improvement of the energy performance and dwellings' comfort are: 1) increasing the thickness of thermal insulation including thermal bridges break, 2) a complete replacement of the windows improving thermal and solar features, and glazing of loggias with a possibility for addition of the new layer. The IMS building model is used for the simulations (Meander building - lamella 4). Three models for improvement of the parapet façade structure are selected:

- **Model M1- window exchange:** is characterized by a replacement of the existing windows with double glazed windows (4+12+4), made of five-chamber PVC profiles ($U=1.4W/m^2K$); glazing of loggias with thermo-insulating glass panels(4+12+4), laid in five-chamber PVC profiles ($U=2.3W/m^2K$). The heat needs are presented in Figure 132 on the left.

•

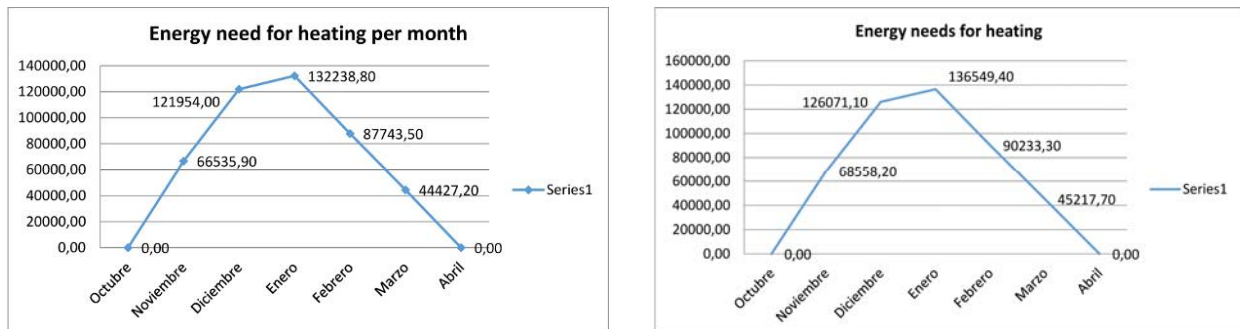

Figure 132: Model M1 (left); Model M2(right), see: Appendix - Energy needs for heating: Parapet façade

- **Model M2- wall thermal refurbishment:** is characterized by the following architectural improvement: an increase in thickness of the thermal insulation of the external wall to 5-10 cm of added expanded polystyrene ($U=0,371W/m^2K$); an increase in thickness of the thermal insulation of the attic slab to 22cm - 10cm of added hard mineral wool ($U=0,171W/m^2K$). The heat needs are presented in Figure 132 on the right .
- **Model M3:** is characterized by the improvements of all envelope subsystems: **Parapets:** an increase in thickness of the thermal insulation of the external wall to 8cm of added expanded polystyrene ($U=0,255W/m^2K$); **Windows:** replacement of the existing windows with triple low-emission glazed windows with argon filler, made of five-chamber PVC profiles ($U=0.9W/m^2K$); **Roof:** an increase in thickness of the thermal insulation of the attic slab to 22cm - 10cm added hard mineral wool ($U=0,171W/m^2K$); **Loggias:** glazing of loggias with thermo-insulating glass panels (4+12+4), laid in five chamber PVC profiles ($U=2,3 W/m^2K$).

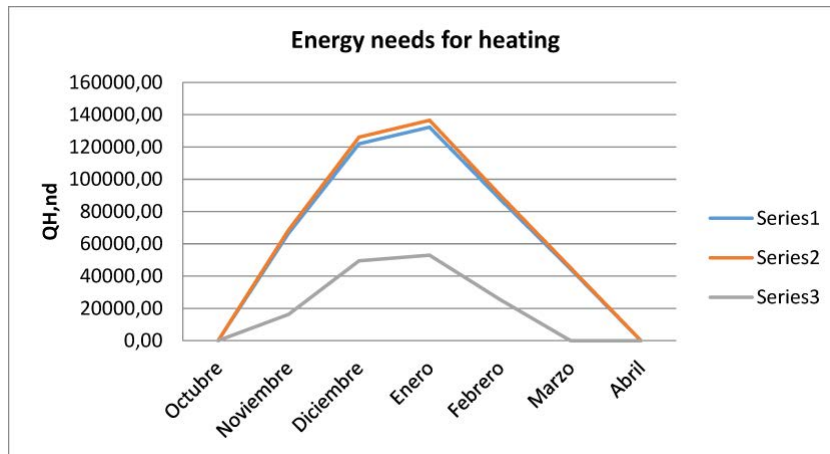

Figure 133: Energy needs for heating QH,nd: Different models' results

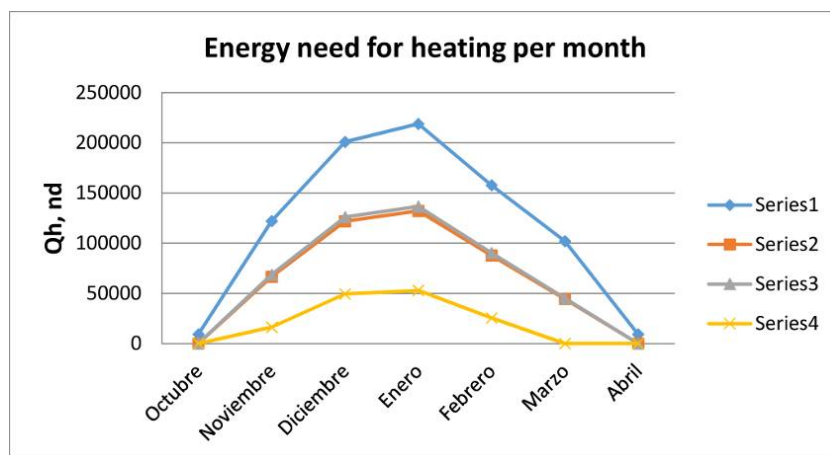

Figure 134: Energy need for heating per month according to three refurbishment models: 1- Current situation of the envelope; 2 - window exchanging scenario; 3 - thermal improvement scenario; 4 - windows replacement and thermal improvement - integrated approach.

The three envelope refurbishment scenarios are compared in Figure 134. Integrated refurbishment strategies for thermal improvement of windows, loggias, parapets, slabs, flat roofs result in total annual energy needs for heating of $QH, an = 144170.3 / 6005.7 = 24.01 (kWh/m^2a)$. This value complies with the standard limit of 70 kWh/m²a for the existing buildings.

A refurbishment scenario for upgrading of a parapet façade structure is proposed in Figure 135. The industrialized components and simple mechanical joints are used for the connections between exiting model and new systems and components.

The building envelope has been analyzed for the integration of more energy efficient systems as well as the new measures for the retrofitting of the dwelling units. The following measures aim to improve energy performances of the building envelope and can be listed:

- Laying or improvement of the thermal insulation and heat-bridges break, creating conventional structures;
- Addition of the bay windows, balconies and loggias (usually glazed) as the independent structures to increase the size of flats.
- The application of passive solar systems: i) enlargement of south facing rooms; ii) increase in size of south facing windows; iii) glazing of south oriented external spaces - balconies and loggias becoming sunspaces, accompanied with thermo-accumulating walls in glassed-in spaces, if possible; iv) glazing of north oriented balconies and loggias that become buffer zones; v) transformation of south facing solid walls into solar walls.
- The application of active solar systems that includes: i) installation of solar collectors on the roof for hot water and space heating, or PV modules providing electrical energy.

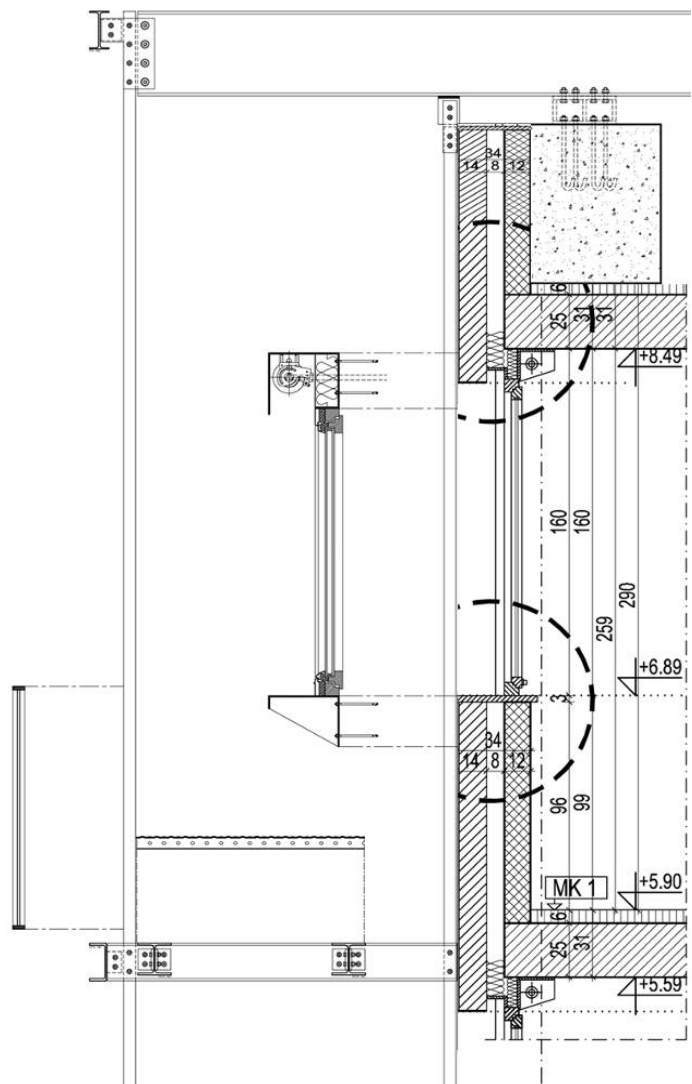

Figure 135: Refurbishment scenario of the building envelope with additional subsystems and components (windows exchange, new balconies, shading, new glazing)

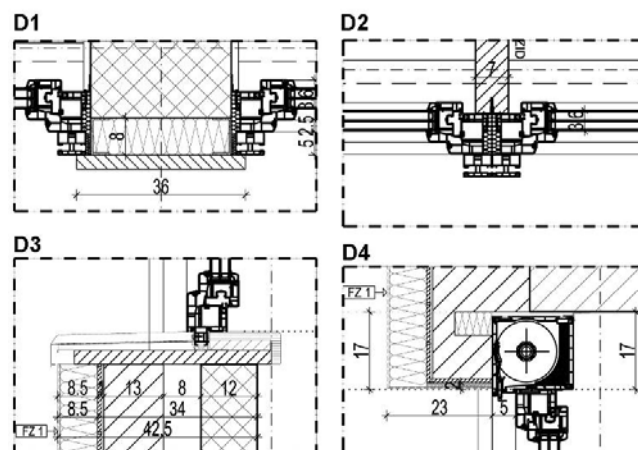

Figure 136: Solutions for the thermal bridge break in the joints: D1 (window-column); D2 (windows - partition wall); D3 (window - parapet); D4 (window- floor slab).

Key tasks in order to improve the building envelope are:

- Well-designed outside insulation (min. 10 cm),
- Insulation against cold-bridges (connections between components from different clusters) Figure 136,
- Insulation of flat roofs (min. 20 cm), creating green roofs when possible,
- Improved windows with 3 layers of glass to the north façade,
- A size decrease in the north facing windows where possible,
- Improved windows with 2 layers of glass to the south façade,
- A size increase in the south facing windows where possible with shutters,
- Built-in glazed loggias as sunspaces,
- Solar devices: PV panels for electricity, solar collectors for domestic hot water, sunspaces, a solar energy storage.

The described proposal has two phases: 1) the construction of a new, insulated roof with PV panels; 2) later implementation of a ventilation system. In both the phases there are common elements that must be installed with an agreement of all owners: The PV panel on the roof and the ventilators and heat recovery units for the ventilation systems. There is also some equipment that each owner has to install to connect with the PV panels and the ducts that provide each dwelling with artificial ventilation and hot water (Brennecke, Folkerts, Haferland, Hart, 1984)³⁵.

• *Installation systems refurbishment measures*

The planning, design, development, construction and operation processes for the future upgrading of the buildings will distinguish the two different installations levels: the building level/general services and the units level supply system. The use of penetrating connections between the primary structure and

³⁵ Brennecke W, Folkerts H., Haferland F., Hart F. 1984. Dachatlas - geneigte dacher: 104-117. Munchen: Institut fur internationale Architektur - Dokumentation GmbH.

installation systems should be avoided. The entire installation accommodated in the load-bearing floors leads to confusion of different systems and causes problems in the coordination of each individual system.

In the future, adaptability actions involving installation components (all cables, wiring, pipes and duct) must be distributed independently of the bearing walls, shear walls and floors. The changes of the rooms involves moving inner walls that should be free from installations components.

• *Load-bearing structure retrofitting*

According to the independency of the load-bearing system, it is possible to apply measures to repair the damaged components. Corrosion is the main problem for the load-bearing elements deterioration. Taking into account the height of the buildings, the magnitude of the stresses to which the structural elements are exposed and the severity of the damage, the immediate restoration of these elements is necessary in order to restore their strength capacity, thus ensuring its durability. Here are proposed the following measures:

- Shoring of the structure if the residual capacity requires it.
- Scarify concrete with the use of mechanical means to remove soft tissue.
- Release of concrete reinforcements, all around it (minimum 2.5 cm.) Also, using mechanical means.
- Clean the oxides and reinforcements.
- Restore the bearing capacity of reinforcements if necessary.
- Apply manually primer for preventing access of chlorides retained in the concrete mass.
- Restoration of the sections of the elements with the use of structural mortar.
- Implementation of secondary protection by a surface coating (paint) to help prevent further penetration of external aggressive agents. This painting should preferably be waterproof and breathable. To guarantee the good maintenance of the reinforced concrete elements, it is necessary to repair the entire plumbing network, including the hanging support networks and waterproofing drain areas (Diéguez-Cruz et al., 2010).

8.2.2 Refurbishment scenario for industrialized housing model

• *Annex of attics on the top of the flat roofs*

Annex of attics represents a set of integrated refurbishment strategies for structural, functional and energy efficient housing upgrading. The attics were built to obtain new dwellings and for the refurbishment of the existing underneath dwellings exposed to the problems of the flat roof. A strategy was to increase the number of flats without increasing the number of buildings and to use the existing infrastructure, thus reducing the cost per sq. m.

Main factors for structural transformations of the flat roof are inadequate technical solutions and building practice, as well as the poor quality of material resulting in the frequent leaking of the roof creating poor living conditions in the flats underneath. Integrated refurbishment scenario aboard the next strategies , energy-efficient measures and structural transformations:

- A need to elaborate standards for the design and construction of the new attics' models, as well as for adaptation of the existing ones to obtain the slope roof;
- Development of (industrial) systems assemblies for building attics on top of flat roofs, which would enable rapid and cheap construction without disturbing the life of the tenants;
- Development of the industrialized flexible and transformable building models for the new attic structure;
- Improving the living comfort on the top floor - improving the living comfort in the flats underneath;
- Cost-effective building of new dwellings;
- Improvement of the energy performance (upper floors overheating and heat losses in winter);
- The expansion of housing units on top floors of the existing buildings;
- The use of the existing infrastructure;
- Improving the technical conditions of the entire building,

The newly applied attics construction has to minimize an additional load on the existing construction, made of prefabricated systems (concrete panel system or skeleton). In that sense, light roof constructions, wooden and metal, are applied. Energy-efficient measures were applied: 1) 12-15 cm thermal insulation thickness (mineral wool or polystyrene) providing U value lower than regulated ($U \text{ value} = 0,65 \text{ W/m}^2\text{K}$); 2) ventilated roof structure, which prevents overheating and condensation. The most suitable roof cladding is corrugated metal roofing because it is light and easy for covering.

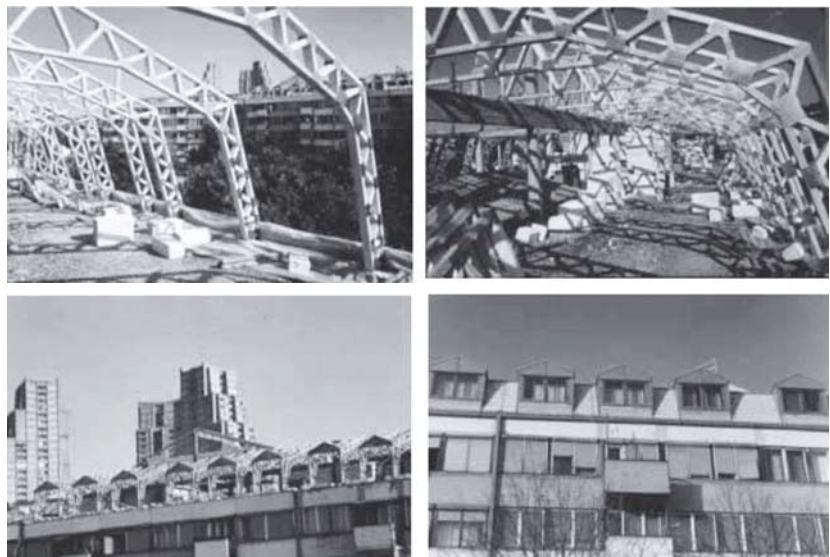

Figure 137: Attics annex at Uciteljsko naselje - attic construction made of wooden trussed girders

The settlements Uciteljsko naselje, Konjarnik , Block No. 23 and Miljakovac can be separated as the significant examples of the attics annex in Beograd. At Uciteljsko naselje, the attic construction does not come from a building system. It is made of prefabricated wooden trussed girders which form frames or arches. A special wooden construction, that forms openings, is supported by them (Figure 137).

At Miljakovac, the structural system of the attic is a mixed construction. A reinforced concrete structure of galleries and a wooden roof skeleton are supported by masonry walls (existing concrete walls) (Figure 138).

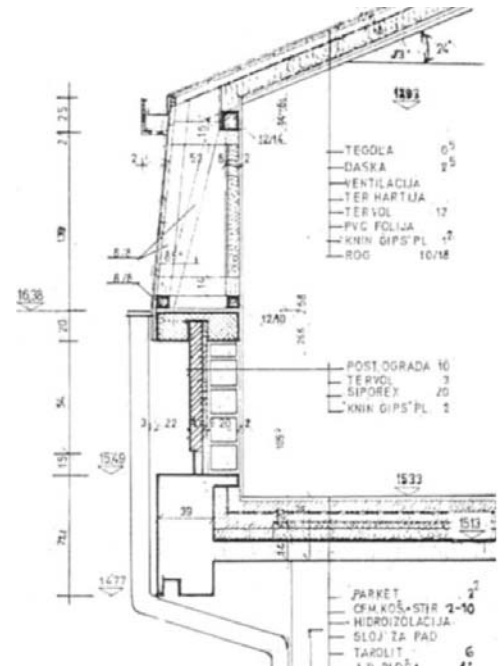

Figure 138: Attics annex at Miljakovac settlement (Krstic -Furundzic, 2007)

The attics were built on top of 59 buildings with flat roofs with 6 new dwellings. On the original top floors the overheating in summer and extreme heat losses in winter were resolved and good living conditions in the attics were ensured by using the ventilating system in the roof ceiling.

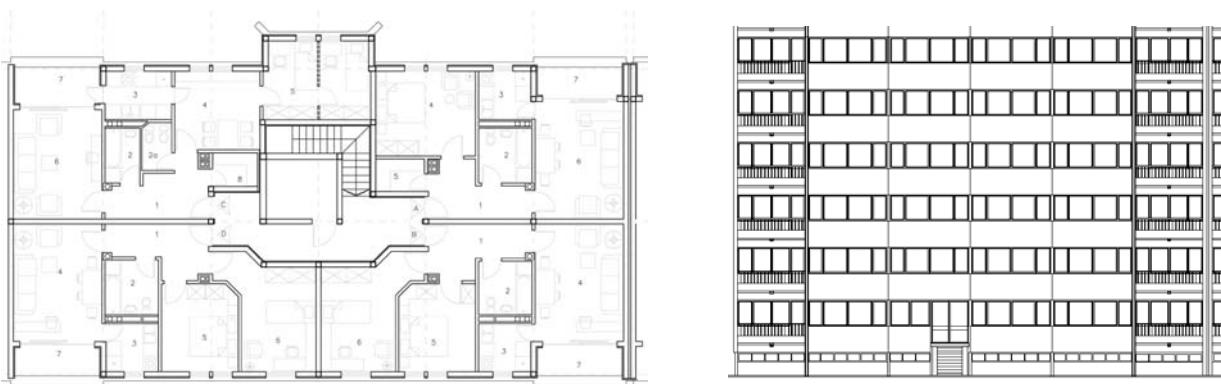

Figure 139: Housing in Konjarnik: Typical floor plan and façade

The housing settlement of Konjarnik (Figure 139) is an example of the massive annex of attics on the top of the flat roofs. Supporting structure consists of the concrete prefabricated wall and floor panels. The structural span between the cross-bearing walls is 3,60 m and 4,20 m. Prefabricated system 'Trudbenik' was applied for the load-bearing structure. Interior partitions are prefabricated bearing panels of 16 cm thickness and non-bearing panels of 10cm thickness. The partitions as the load-bearing components limit alterations within the dwelling's layout. Functional changes in the dwellings are possible along with the transversal axes. The conventional construction system is applied for the attics. New attics and the existing building form a mixed building model of industrialized panel system, conventional construction on site and the prefabricated non-bearing façade (Figure 140).

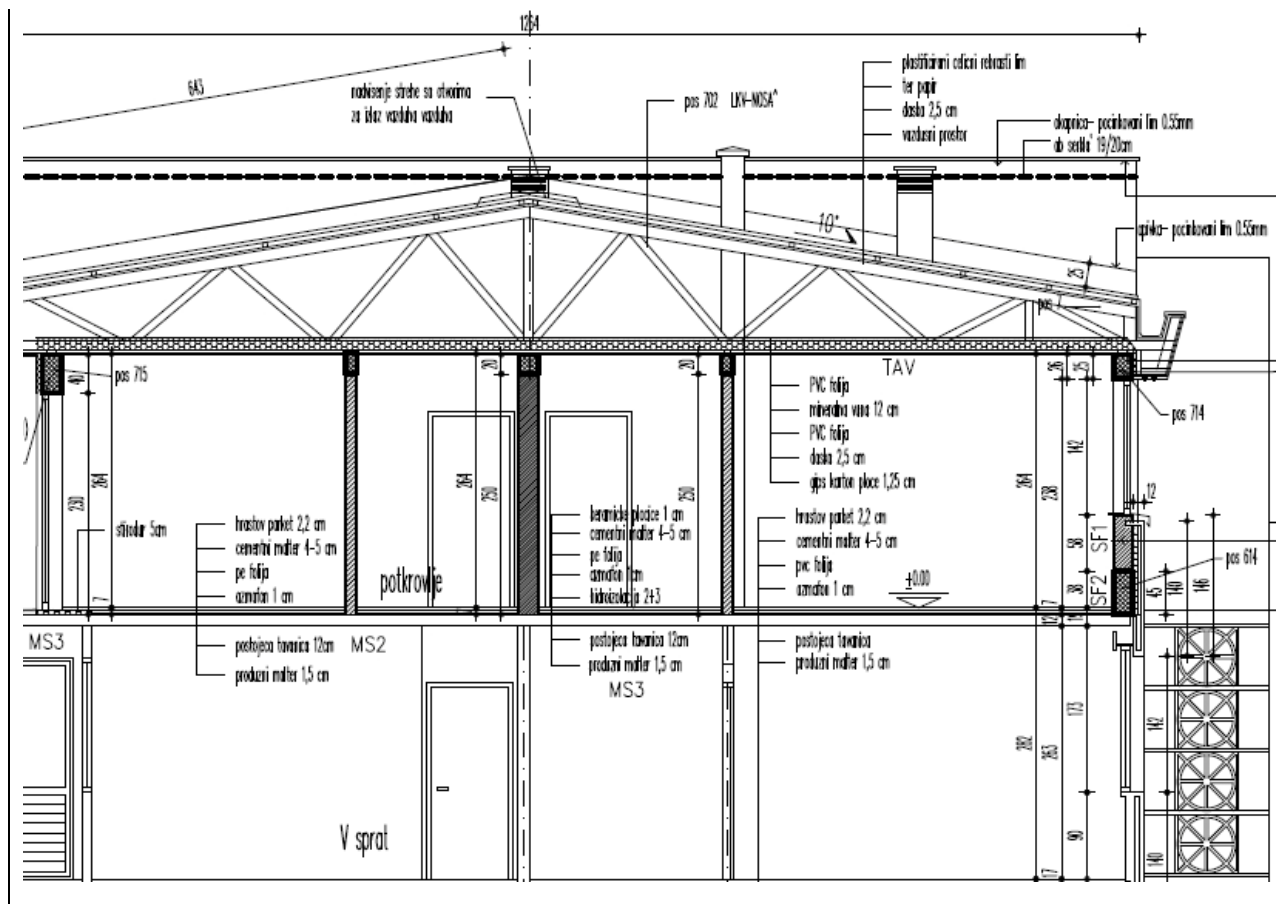

Figure 140: Attics annex at Konjarnik settlement

8.3 Improvement of the dwellings' comfort

The main problems at the dwelling level come from the bad envelope conditions. The tenants themselves have performed different repair solutions and adaptations of balconies and loggias which cause many problems with the air and water infiltrations. The important cold bridges cause energy losses and moisture inside the dwellings. Principal aim of the dwellings' refurbishment is to use the state provided incentives with the small investments for the tenants, to reach the energy efficiency standards. To achieve that, the retrofitting strategies should include:

- **Passive retrofitting** with a new thermal isolation of the envelope and windows replacement; adding the energy savings components like solar walls, advanced glazing systems, sunspaces;;
- **Renewable retrofitting** with a thermal energy storage;
- **Active retrofitting** with renovation of the HVAC system.

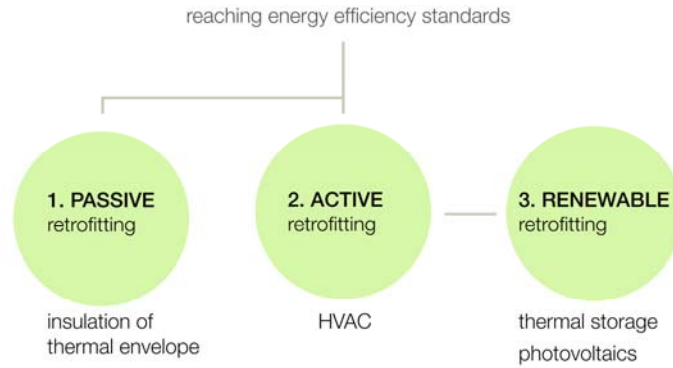

Figure 141: Integrated refurbishment scenario

The refurbishment scenario for the dwellings is based on the building envelope retrofitting and HVAC systems upgrading (Figure 142). According to the numerous units per building, retrofitting actions should be planned to allow a normal living for tenants. Improving the thermal conditions of the façade and improvement of the flat roof will contribute to the internal air quality and better living conditions. The new upgraded airtight envelope will be integrated with the new ventilation system to control dwelling comfort .

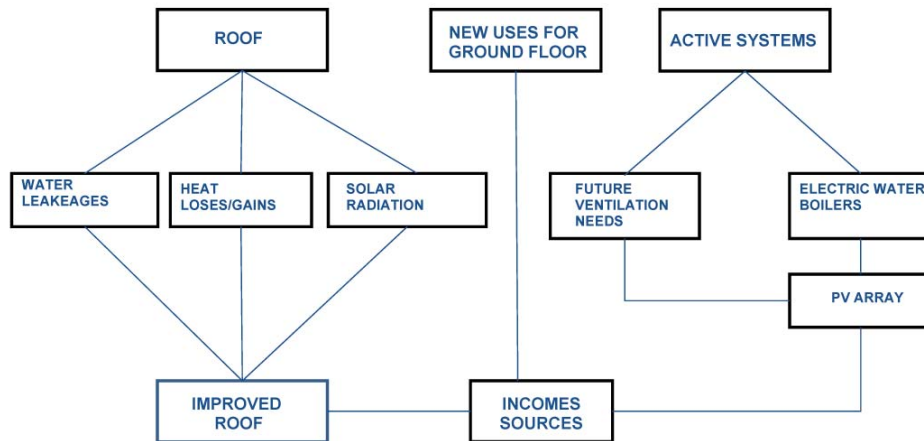

Figure 142: Integrated refurbishment strategies

The simulations are carried on the Meander building. A sample of three apartments around vertical communication and the total surface about 200 m² has been analyzed (Figure 143). The measurements were made in three apartments on the top floor. The envelope components that influenced a dwelling comfort are: floor with the heated underneath dwellings, ceiling towards unheated attic and façade walls.

The heating is provided by a district heating scheme and in the medium term a surge in cooling demand is not expected. Nevertheless, there is a scope for the production of renewable electricity given the fact that hot water is currently provided by individual electrical boilers. Therefore, a new pitched roof is proposed with PV panels attached. This structure will produce a shaded, ventilated space over the former roof that will also be insulated and generate the space for the future ventilation system using existing chimneys for the installation of the ventilation ducts.

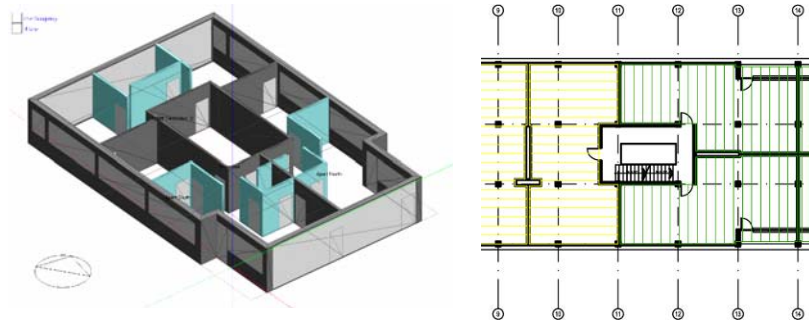

Figure 143: Meander building: three dwellings per stairs experimental module

Before measurements, the following changes had been performed. The windows had been replaced in the apartment. The new PVC windows with low glass emission coefficient and overall thermal transmittance of $U = 1,4 \text{ W/m}^2\text{K}$ were embedded. Heat transmission of the different structural parts for the building rehabilitation are: walls = $0,3 \text{ W/m}^2\text{K}$; roof = $0,14$ and $0,16 \text{ W/m}^2\text{K}$; slab= $0,37 \text{ W/m}^2\text{K}$; cornice = $0,27 \text{ W/m}^2\text{K}$.

A calculation of the energy required for heating is based on the heat balance equations for each construction element. The energy (heat) balance at the building level includes the following terms: transmission heat transfer between the conditioned space and the external environment; ventilation heat transfer (by natural ventilation or by a mechanical ventilation system to be installed), transmission and ventilation heat transfer between adjacent zones; internal heat gains (including persons, appliances, lighting and heat dissipated in, or absorbed by, heating, cooling, hot water or ventilation systems); solar heat gains (direct, through the windows, or indirect, via absorption in the opaque building elements); storage of heat in, or release of the stored heat from the mass of the building; energy need for heating.

For each building zone and each calculation step (one month), the building energy need for heating, $Q_{H,nd}$, and the conditions of continuous heating, are calculated as given by equation:

$$Q_{H,nd} = Q_{H,hd} - \eta H_{,gn} * Q_{H,gn}$$

The retrofitting process simulation has been applied for the most common façade solutions of rows of parapet and windows. According to the 2015 measures (Phil, Werner, Jo, & Philipp, 2014): U-values ($\text{W/m}^2\text{K}$) of the windows (simple flat glass + wooden frame) are running between $2.79 - 3.05 \text{ W/m}^2\text{K}$. ;

the parapets and walls have the U-value from 0.68 to 1.70 W/m²K; the partition walls with neighbors: U= 2.80 to 3.70 W/m²K; the floor slab above the non-heating space: U= 1.15 W/m²K.

8.3.1 Passive Retrofitting

According to the passive strategies, thermal isolation of a building envelope and windows replacement in the year 2017 may achieve the following results: U (window) = 0.90 W/m²K; U (wall) = 0, 28 W/m²K; U (partition walls between dwelling units) = 0.67 W/m²K.

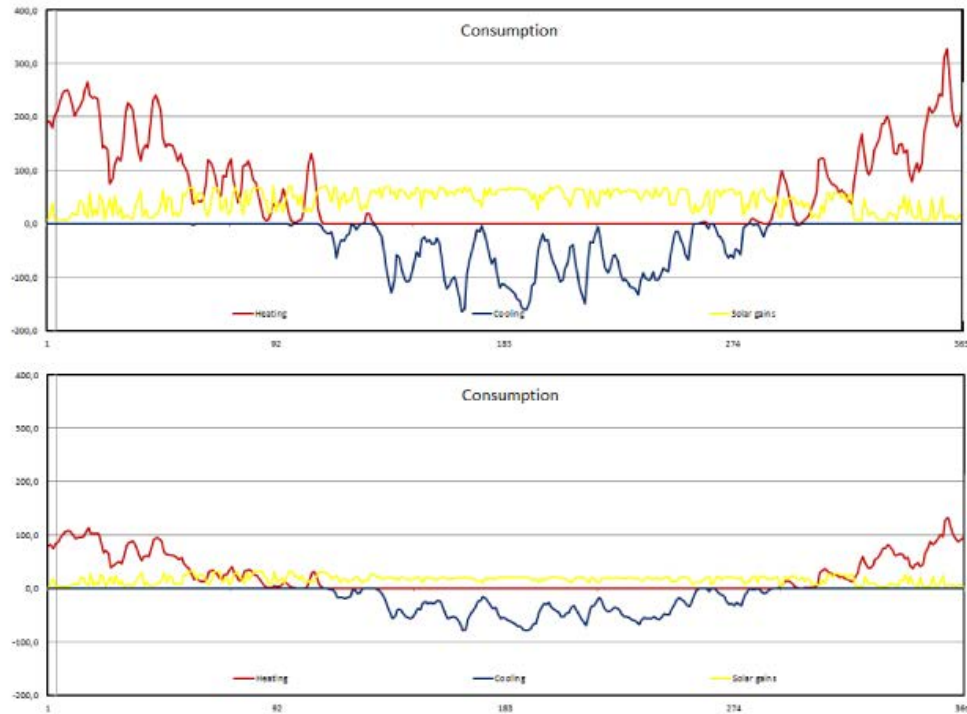

Figure 144: Energy consumption before and after envelope thermal retrofitting (heating-red line, cooling-blue line, solar gains-yellow line)

According to Figure 144, the current situation of the building envelope is presented on an energy consumption diagram for heating, cooling and solar gains (above). Energy consumption for lighting is about 23 % from the total energy consumption with the corresponding $Q_{H,n,d} = 25,05 \text{ kWh/m}^2$. Respectively, energy consumption for cooling (31%), heating (56%) is $61,30 \text{ kWh/m}^2$ and $112,59 \text{ kWh/m}^2$. The energy is needed mostly for heating. After the refurbishment process, the expected results in 2017 are:

- Energy consumption for lighting 12% with corresponding $Q_{H,n,d} = 10,34 \text{ kWh/m}^2$;
- Energy consumption for cooling 39% with corresponding $Q_{H,n,d} = 34,58 \text{ kWh/m}^2$;
- Energy consumption for heating 49% and corresponding $Q_{H,n,d} = 43,44 \text{ kWh/m}^2$.

The total energy consumption of QH,n,d = 43,44 kWh/m² in 2017 is under the regulations limits of 70 kWh/m²a for the existing buildings (Figure 145).

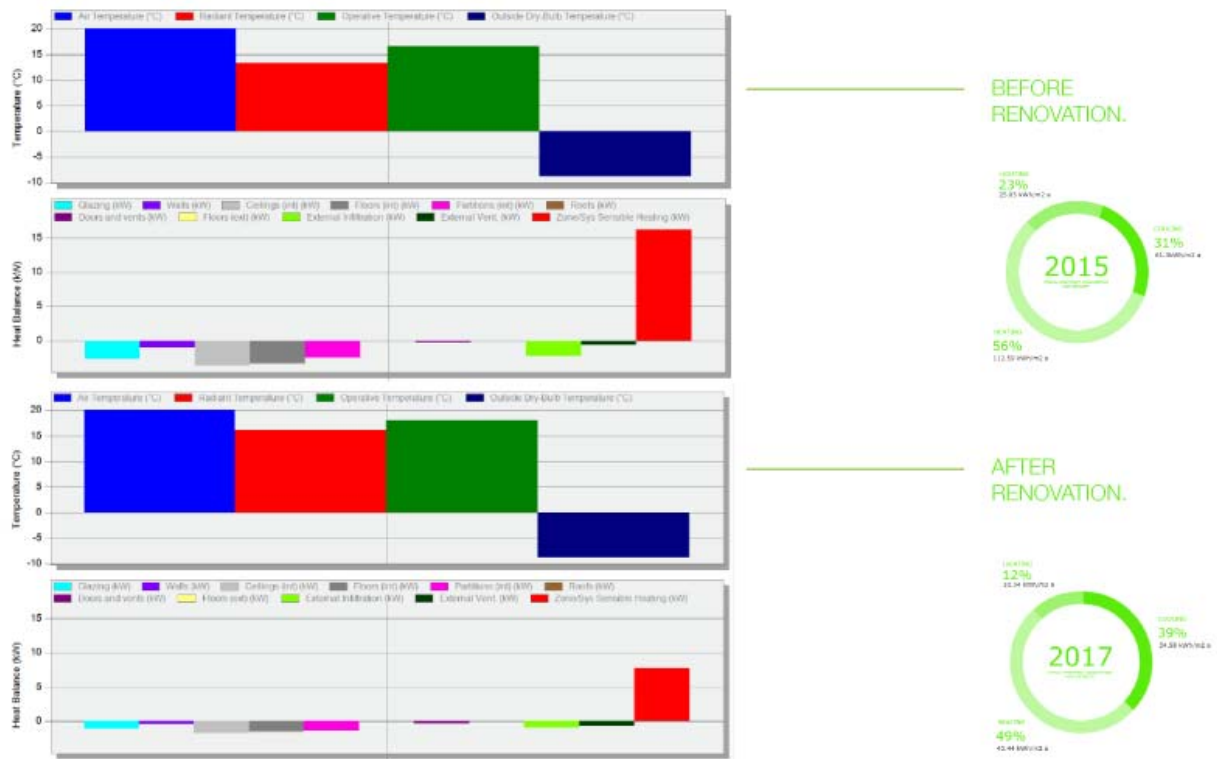

Figure 145: Temperature and heat losses (Cullen, Salih, Rashevski, Zigart, & Nikolic, 2015)

Before retrofitting, the CO₂ emissions reach 27,364 kgCO₂/kWha (136 kgCO₂/kWh/m²a). With the passive retrofitting the expected results in 2017 could be reduced to 65 % , 12,105 kgCO₂/kWha (60 kgCO₂/kWh/m²a) (Figure 146).

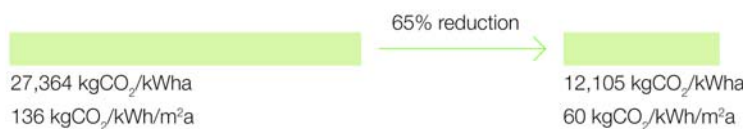

Figure 146: CO₂ emissions

Transformation at the dwelling unit level - final recommendations:

- **Interior partition changes:** Removing fixed interior partitions for enlargement and changing the functional disposition.
- **Increase the size of the living room:** This is achievable by extension of a structural module at least by a cantilever slab for an extra 5.80 m², without reducing the number of rooms. However, the

increase in size is limited to a maximum of 200cm for the cantilever slab according to the current IMS construction technology limits.

- **Increase the size of the master bedroom:** Again, this is achievable with functional reorganization. The increase in size is further limited to a maximum of 100mm to 300mm and in two cases and a master bedroom with an irregular shape may be created.
- **Increase the number of bed-rooms:** Providing an additional room (as study or small bedroom) can support the common scenario with a need to form an additional room.
- **Merging two rooms for a larger room:** This is achievable in different ways.
- **Merging two flats to form double-sided orientation dwelling:** grouping of two dwellings ($2 \times 42.86 \text{ m}^2 = 85.72 \text{ m}^2$; $1.5 \times 42.86 \text{ m}^2 = 64.29 \text{ m}^2$); future division of the compound dwelling in different ways according to the future needs (flats with one or two entrances).
- **Transformation of the load-bearing structure:** An extension of the load bearing structure by a larger cantilever system: to obtain loggia space and/or a larger living room area.
- **Transformation of the installation systems - adding new installation blocks:** joining them with the shier walls will permit more flexibility in disposition of the kitchens and bathrooms.
- **Galleries and loggias:** disassembly of the reinforced concrete balustrades; modification and repair of steel posts of loggias and their fixing; repair of the reinforced concrete elements of loggia with a replacement of the old flashings and the exchange of finishing layers; making of new light steel balustrades from full screens and clearance at pit.

8.3.2 Renewable Retrofitting

The photovoltaic collectors and thermal storage are the integrated strategies for the new electric power source and heating. The simple simulation has been done for the installation of 120 m^2 of photovoltaic cells (per module of 200 m^2 of dwelling area); and 45 m^2 of solar collectors (Figure 147).

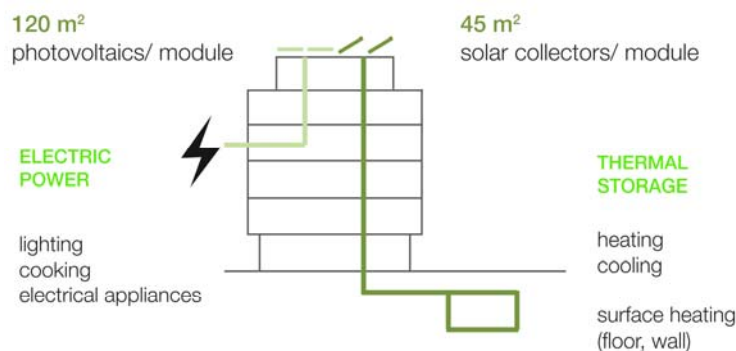

Figure 147: Renewable retrofitting scenario

For the simulation has been used The Photovoltaic Geographical Information System (PVGIS)³⁶ in order to make estimates for the performance of PV systems. First simulation is done with the PV collectors to be installed without slope with the peak PV power of 5 KWp. The total annual power production reaches 5.200,00 kWh/a (Figure 148). Figure 148 presents average monthly electricity production from the given system (Em- value). According to the price 1.50 €/W for the 5000 W the price of the system installation will be 7.500€ If we sell the annual energy production (0,26666 €/kW) we have annual savings of 1.386,66 € With the pitch roof of 30 degrees the total annual production reaches 6.000,00 kWh/a.

Location: 44°48'53" North, 20°25'46" East, Elevation: 77 m a.s.l.,
Solar radiation database used: PVGIS-CMSAF

Nominal power of the PV system: 5.0 kW (crystalline silicon)
Estimated losses due to temperature and low irradiance: 9.0% (using local ambient temperature)
Estimated loss due to angular reflectance effects: 4.0%
Other losses (cables, inverter etc.): 14.0%
Combined PV system losses: 24.9%

Fixed system: inclination=0 deg., orientation=0 deg.				
Month	Ed	Em	Hd	Hm
Jan	4.72	146	1.20	37.3
Feb	7.84	219	1.96	54.8
Mar	14.50	449	3.69	114
Apr	18.70	561	4.90	147
May	21.70	674	5.84	181
Jun	23.30	700	6.39	192
Jul	23.80	737	6.57	204
Aug	21.00	650	5.76	179
Sep	15.30	460	4.09	123
Oct	10.80	335	2.84	88.2
Nov	6.07	182	1.60	48.0
Dec	3.78	117	0.98	30.5
Year	14.30	436	3.83	117
Total for year		5230		1400

Ed: Average daily electricity production from the given system (kWh)

Em: Average monthly electricity production from the given system (kWh)

Hd: Average daily sum of global irradiation per square meter received by the modules of the given system (kWh/m²)

Hm: Average sum of global irradiation per square meter received by the modules of the given system (kWh/m²)

Figure 148: PVGIS estimates of solar electricity generation (see: Appendix - Photovoltaic Geographical Information System (PVGIS) simulation of the performance of PV system)

For the simulation of thermal performance has been used the Design Builder software in order to make estimates for the performance of thermal collector system. For dwelling area of 200 m² the total annual heating consumption is 8800 kWh/a (Table 6). The total surface of 40 m² is planned to be cover with the thermal collector.

³⁶ <http://re.jrc.ec.europa.eu/pvgis/apps4/pvest.php#>

HEATING NEEDS

Heating per module	8800											
Annual daydegrees	2520	Calculated:										2517,99
Average interior temperature	19,35											5
Coefficient of coincidence	1	1	1	0,82	0	0	0	0	0	0,5	1	1
Month	January	February	March	April	May	June	July	August	September	October	November	December
Days per month	31	28	31	30	31	30	31	31	30	31	30	31
Outside temperature	1,4	3,1	7,6	12,9	18,1	21	23	22,7	18	12,9	7,1	2,7
Daydegrees monthly	556,45	455	364,25	158,67	0	0	0	0	0	99,975	367,5	516,15
Part of heating energy to total annual energy	22,08%	18,06%	14,45%	6,30%	0,00%	0,00%	0,00%	0,00%	0,00%	3,97%	14,58%	20,48%
Part for heating kWh	1943	1589	1272	554	0	0	0	0	0	349	1283	1802

Table 6:: Annual heating needs (see: Appendix - Energy need for heating (200m² module): Consumption and Production balance)

Installed heating power of 8 kWh/a can produced 10964 kWh of heating power. From the obtained value the 5044 kWh is needed for accumulation (57.32 %) to cover annual needs for heating. The available energy for accumulation and storage will be 7215 kWh (65.60 %). In Figure 149 is presented the annual balance of the energy consumption and production according to propose scenario.

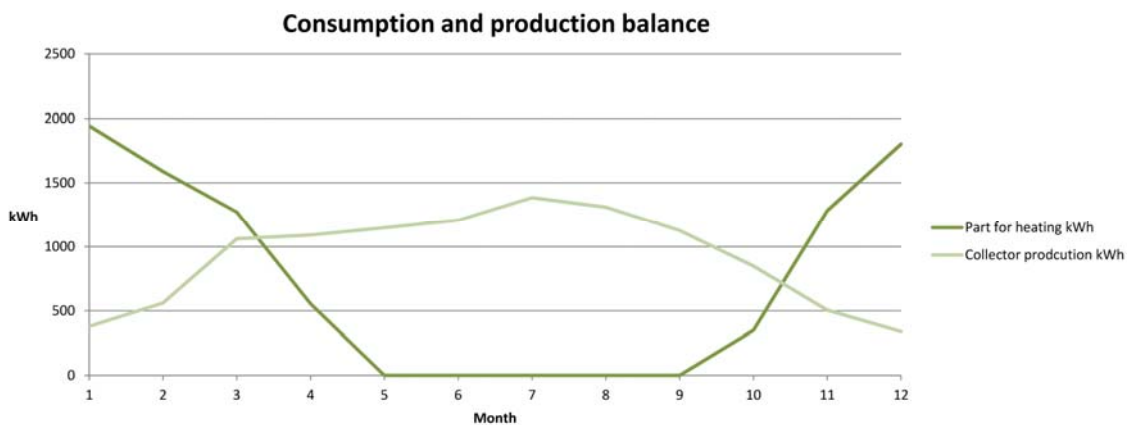

Figure 149: Annual consumption and production(see: Appendix - Energy need for heating (200m² module): Consumption and Production balance)

8.3.3 Active retrofitting

Active retrofitting should include mechanical ventilation with heat recovery. The vertical communication cores in the low and medium-rise housing are suitable for the installation of mechanical ventilation system from the roof top to each unit .

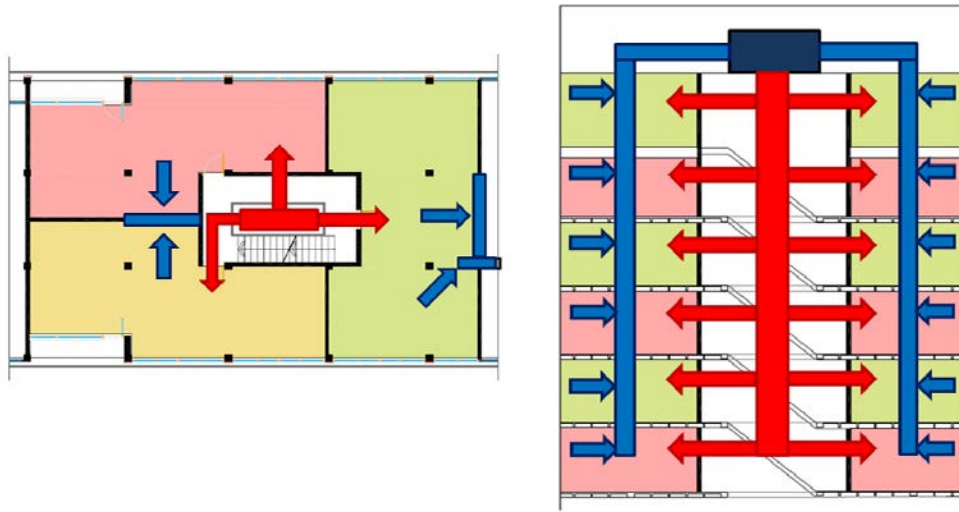
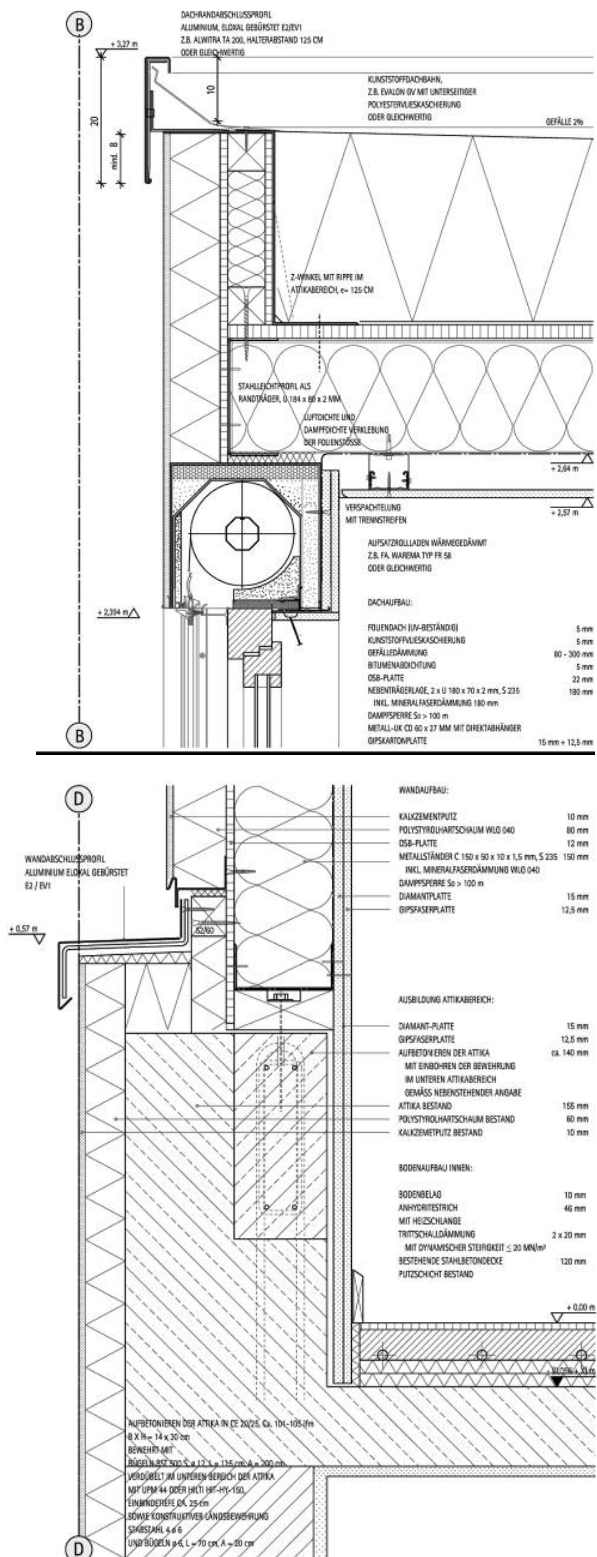

Figure 150: Mechanical ventilation with heat recovery

8.3.4 Dry construction

Defining dry construction as a combination of lightweight components and simple connections is not new, but its application for the refurbishment of the industrialized massive blocks in Beograd is the solution. The refurbishment scenarios are based on the three fundamental principles: 1) lightweight systems and structures with simple and demountable joints; 2) systems assembly procedures; 3) semi-finished or finished products. It will be suitable for the transformations of the existing housing models because of the short construction time, good economics, environmental friendly materials, good insulation and fire protection benefits, compared to the conventional construction with the same overall component thickness. The integration of retrofitting systems and the flexible system of joints can make the obsolete housing building more flexible for the future changes. The complex combination of physical building requirements, functional requirements and technological requirements - such as sound insulation, fire protection, moisture control and thermal performance, functional changes, rooms size changes, façade changes, could be fulfilled simultaneously.

Light-weight systems and components can be added to the existing BM in order to improve specific properties and a very important aspect for making new dwellings on exiting building (adding new floor or attic, spatial expansion and extensions, re-arrangement of the interior space). Moving on, from the materials level to the components and systems, semi-finished or finished products, the lightweight structure is faced with the task of bearing a given load with a minimum of self-weight. A clear reduction of loads is achievable with the light wall systems (partitions, external walls, and façades). These are primary mechanical loads that have to be transferred within the existing framework without or with a minimum disturbing the existing structure. A lightweight structure represents the solution that minimizes boundary conditions (overloading of the existing structure, extension of the existing structure, two or three dimensional transformations and functional changes...).



- Fascia plate to edge of roof, anodized, brushed aluminum, E2/EV1
- Roof construction: UV- resistant sheeting synthetic fleece facing insulation with integral falls, 80-300mm bitumen waterproofing; 22mm OSB, secondary beams S 235, 2No. 180x70x2mm channels 180 mm mineral-fibre insulation, WLG 040 vapor barrier , $s_d > 100$ m metal CD section, 60 x 27 mm, with 40 mm hanger brackets 12.5 mm plasterboard
- Joints in sheeting glued airtight and vapor-tight Lime-cement render
- Rigid polystyrene foam, WLG 040, 80 mm OSB, 12 mm
- Metal studs, S 235, 150 x 50 x 10 mm, $d = 1.5$ mm, with mineral-fibre insulation, WLG 040
- Vapor barrier
- Plasterboard with skim coat
- Flashing, anodized, brushed aluminum
- Timber plank, 60 x 150 mm, for mounting prefabricated lightweight steel elements
- Anchors in new parapet section cast-in-situ, grade C 20/25
- Reinforcement: U-bars cast into existing parapet, longitudinal bars and shear links
- Existing reinforced parapet
- Existing rigid polystyrene foam, 60 mm
- Existing lime-cement render, 10 mm
- Floor construction: wood-block flooring, 45 mm calcium sulphate screed with under floor heating , 2No. 20 mm impact sound insulation
- Existing reinforced concrete roof slab, 120mm

Figure 151: Detail of the light-weight new attic construction (Appendix - Refurbishment scenarios for post-war housing in Europe: State-of-the-art)

9 Conclusions

Based on the conducted research the thesis conclusions are multi-layered:

- A.** According to the analysis of the industrialized housing model composition we can conclude:
- 1. Open prefabrication was well suited for the post-war housing regeneration.**
 - 2. Post-war housing is Industrialized, Flexible and Transformable (IFT) model.**
 - 3. Transformation capacity of the IFT housing depends on the functional decomposition and independent technical levels.**
 - 4. Transformation capacity is based on components and systems hierarchy assembly.**
 - 5. Transformation capacity is based on the simple joints and interface geometry in connections.**
 - 6. Housing buildings built by IMS (Precast Prestressed Concrete Skeleton) building technology is IFT building model.**
- B.** According to the transformation capacity and dependency conditions of the Building Model (BM) obtained in the stage A, are planned the refurbishment scenarios. Different Building Models will have different scenarios.
- 1. Open building principles are suitable for IFT models refurbishment.**
 - 2. Industrialized building model refurbishment scenario is based on: spatial and technical transformations; passive, active and renewable energy retrofitting.**
 - 3. Industrialized, Flexible and Demountable (IFD) construction and Dry Construction principles are suitable for post-war housing refurbishment.**
 - 4. Graph model report will become a part of the housing refurbishment project.**

A1: Open prefabrication was well-suited for post-war regeneration of Beograd. The Yugoslav prefabrication shifted from a '*prefabricated systems*' to a '*technology of open prefabrication*', providing the users with flexible and adaptable flats and enabling a great deal of individualism and originality to the architects. The efficiency of the building process was reduced because it had to deal with more custom tailored elements and '*ad hoc*' techniques that it was initially supposed. Hence, the great value of the building industry is the development of the Yugoslav prefabricated architecture, its non-uniformity.

The industrialization strategies for housing construction are divided into on-site prefabrication and off-site prefabrication. Another split in industrialization strategies is between product industrialization that focuses on the technological aspects of building and process industrialization that is concerned with how parties are cooperating. It deals with Design and Building of building structures. The process of designing and constructing was 'open' and its participants cooperated very actively, often reaching specific technological solution to adapt to the needs of the individual design. Building components and subsystems could be added with improved autonomy.

A2: Post-war housing is Industrialized, Flexible and Transformable (IFT) model. In the post-war industrialized housing sector the product was the industrialized, flexible and transformable (IFT) system configuration. The IFT model is a set of parts (components, subsystems, systems) and rules for its arranging in the systematic order into technical levels, of which load-bearing and façade levels were independent. The building is composed of primary construction (load-bearing system) and secondary construction (building envelope, services and partitions).

The systematization of independent and interchangeable components and systems by demountable joints allows for various subsystems to be adjusted with an improved autonomy, for building refurbishment. A significant innovation will be required for designing the appropriate physical interfaces and connections between the components for more transformation capacity. Therefore, future integration of systems and components should generally address assembly and disassembly of systems and components.

The main features of the IFT model are:

- i. Functional decomposition: separation of the technical levels, which correspond to independent building functions;
- ii. Hierarchy assembly: creation of the hierarchy of distinct subsystems and components;
- iii. Application of a parallel instead of sequential assembly;
- iv. Simple interfaces of components in connections;
- v. Simple and demountable joints.

This refurbishment measures will be applied for the integration of new systems to the existing housing models.

A3: Transformation capacity of the IFT housing depends on the functional decomposition and independent technical levels. To understand the real complexity of the post-war housing in Beograd, the industrialized models are tested for the decomposition of components and systems in order to understand the level of functional and technical dependency. Two or more different functions mixed in one structural component, as in the case of interior partition walls and their load-bearing function with embedded HVAC elements, represent a strongly dependent structural node.

Industrialized housing models are designed and built according to functional decomposition from the major systems and corresponding components. From the study we can conclude that the IMS housing

models are suitable for the integration of new systems and components in the façade, roof and infill levels. The principal quality of the IMS building technology is the functional decomposition of primary and secondary structures. More permanent connections exist in the huge panel model because of the interior cross bearing walls and embedded shafts for wires into the industrialized façade panels. Huge panel housing models have functionally dependent load-bearing and installations systems. The transformation capacity of the panel structures is limited to the building envelope and infill level.

The IMS skeleton and huge panel configuration models are defined by four technical levels (foundations - Level I; load-bearing system - Level II; enclosing, partitioning, common services - Level III), where the dependency conditions between technical systems and components are analyzed. Though these are especially considered on level IV (Figure 152). The three technical levels and the main functional systems on each level are independent. The load-bearing structure is a higher level and is the 'lot' in which lower levels operate and make changes. On the fourth level there are components that should change with more frequency. All the green filled from Figure 152 represent energy efficient measures, systems and components to be applied for the housing refurbishment.

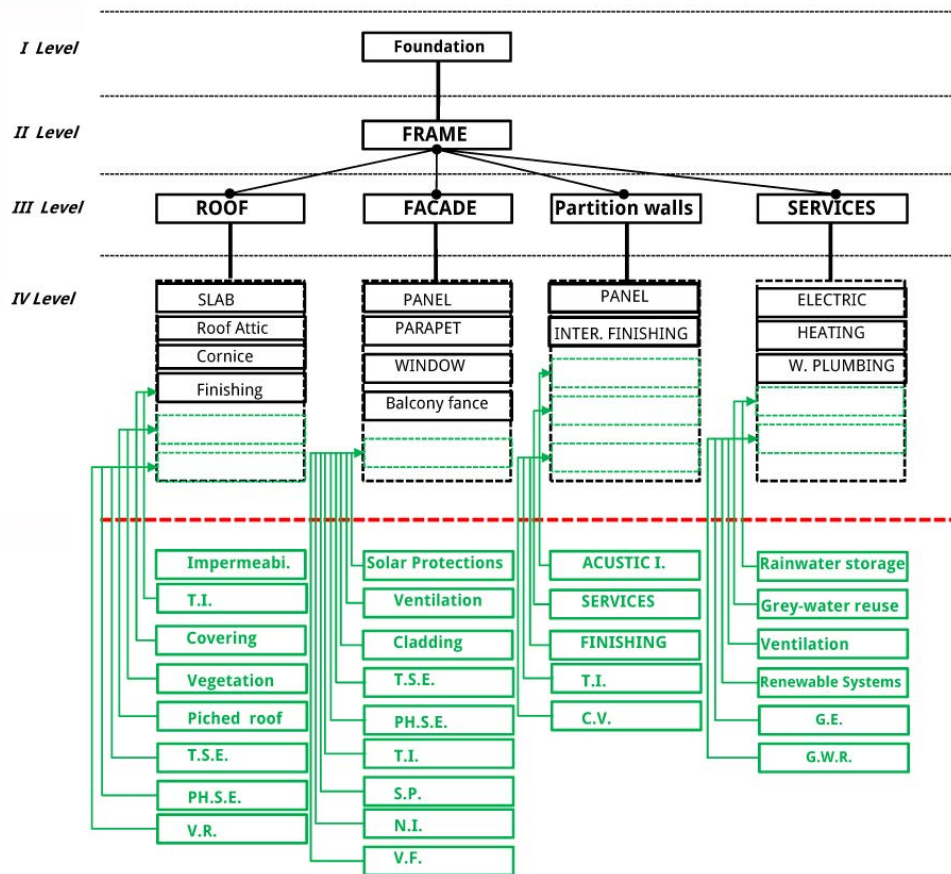

Figure 152: Systematic integration of energy efficient 'measures': TSE_ thermal solar energy; PHSE_ photovoltaic solar energy; SP_ solar protections; NI_ natural illumination; TI_ thermal isolation; VF_ ventilated façade; GE_ geothermal energy; IAD_ industrialization, assembly, disassembly; VI_ vegetation installation; RS_ rainwater storage; GWR_ grey-water reuse; NV_ natural ventilation; CV_ crossed ventilation; TS_ thermal storage; AI_ acustic isolation; etc.

A4: Transformation capacity is based on components and systems hierarchy assembly. The assembly hierarchy of the components and systems in the industrialized housing models takes into account that different parts of the structure have a different lifetime and functional expectances. Industrialized housing model systematized into hierarchy assemblies where adaptability at the component's level is possible according to the compatibility issue and simple joints, is considered a flexible and transformable system configuration. This internal hierarchy determines relations between different elements, and therefore, the easiness or difficulty for changes.

In the IMS systems hierarchy, the independent systems have a base element for making connection with the other subsystems in the hierarchy. The edge girder or cantilever slab is the base element for all elements of the parapet and window assembly (windows' wings, shadings, rails). Such systematization of the building structure through the base elements and their connecting parts stands for a better control of the configuration model, use of exchangeable parts, and future disassembly at the end of the service life. Hierarchy assembly procedures allow for the system configuration to be approved with additional components and subsystems (Figure 153). Various subsystems can be adjusted with improved autonomy according to the compatibility rules and modular coordination in the level IV.

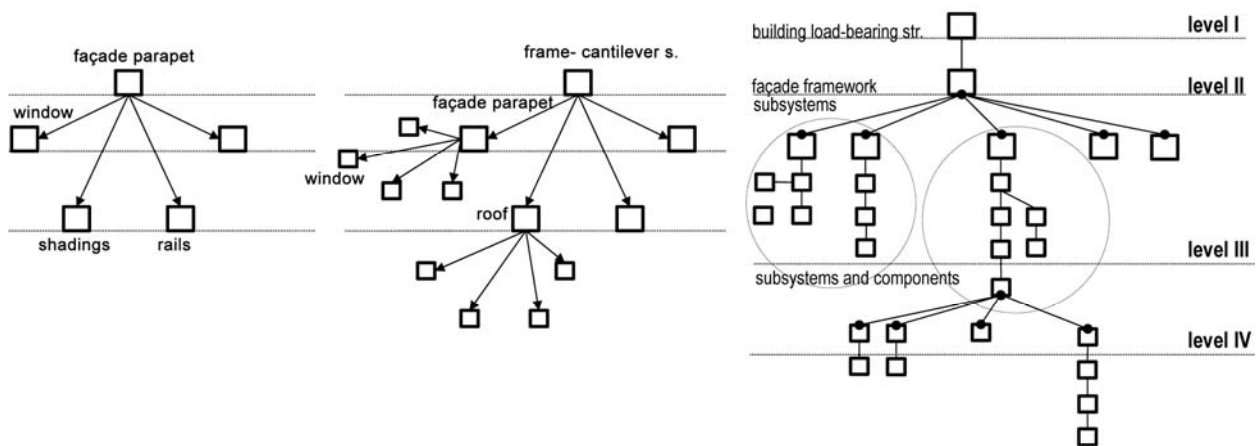

Figure 153: Systematization of components according to base element and hierarchy assemblies

On the load-bearing level, the IMS skeleton is a base system for other subsystems, such as façade, roof, floors, installations, etc. On the subsystem level such as the façade, the parapet is the base element for the windows, etc. The systematization of the components and subsystems into assemblies minimizes the number of relations between elements within the structure. The process is based on specifying a group of parts – subsystems and simple connections between components. Figure 154 shows components assembly of primary structure and complementary components for façade and cantilever of the IMS System 50.

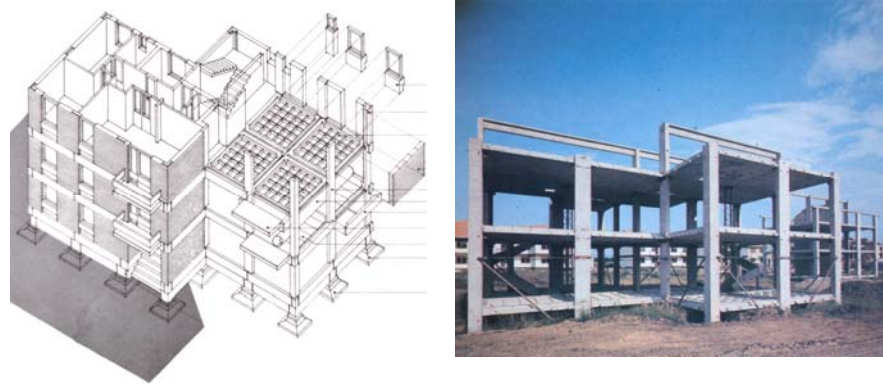

Figure 154: IMS System 50: Industrialized Building Model

A5: Transformation capacity is based to simple joints and interface geometry in connections. In order to evaluate the building structure as an 'open' system configuration, two types of relations have been considered: one between the clusters (subsystems: façade, roof, partition walls, services) and another one within the clusters. The components interface that are connected and the type of connection are the principal conditions for the system transformation capacity. Flexible connections (Figure 155) allow for planning changes without the usual demolition of building parts associated with renovation. The flexible connections support the refurbishment method that won't be reinvented each time a system or component reaches the end of its service life, but can be repeated many times in a variety of possible combinations and going further with customized solutions. The most simple connection are found in the façade cluster, between façade and load-bearing components (Figure 155). The mechanical joint will be used for the system upgrading by exchanging components or integration of new systems.

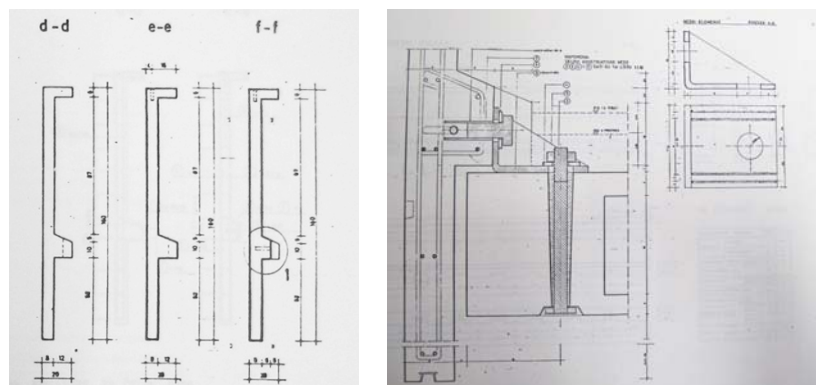

Figure 155:: Demountable connection between cantilever slab and loggia parapet (EG - PWI)

To realize flexibility, the connections between the components (called *interfaces*) also have to be adaptable. The design of flexible interfaces that can be widely applied in the construction industry and aim at the standardization of connections at the various levels of building composition create compatibility between building products from different suppliers.

A6: IMS housing is Industrialized, Flexible and Transformable (IFT) building model. Adaptability of the industrialized building models by structural and functional transformations, combined with a limited use of materials and energy is a strategy that has not been explored before. Industrialized, flexible and transformable aspects of the IMS building technology are mentioned:

- Building structure is an integral part of the design process: design, composition and location of load-bearing components in the building layout;
- Building model systematization: arranging the systems and components in the systematic order of independent functional and technical levels;
- Producing the smallest possible number of components capable of being assembled into the greatest possible variety of housing models;
- '*Open*' hierarchy assemblies for flexibility in the building layout and façade: flexible distribution of the construction elements in the building layout allows a variety of functional distributions for the dwelling units;
- Possibility to change the surface of the floor plan, either by additional construction or by changes in the boundaries of the units outside of the '*support*' limits;
- Connections between the removable parts and load-bearing structure are based on simple joints;
- The IMS building technology has been successfully implemented in the production of high, medium and low-rise buildings;
- IMS technology of '*open*' prefabrication refers to integration of the new components and systems for future sustainable refurbishment of industrialized housing;
- Various subsystems, differing both in technology and materials, can be adjusted with an improved autonomy;
- A structural system that provides flexibility in locating exterior walls and interior partitions;

Regarding the problem of flexibility in the post-war housing, we can emphasize that the application of the assembly method into distinct subsystems, and '*open*' system configuration supports the transformations of the industrialized housing.

B 1: Open building principles are suitable for IFT systems retrofitting. The load-bearing structure of the industrialized housing in Beograd was designed and built considering the flexibility issue to support transformations in the building layout. The principal '*open building*' characteristics of the flexible load-bearing structure are:

- i. Building model division on the primary and secondary structure;
- ii. Long span structures with middle span area free from the load-bearing elements;
- iii. One-directional load-bearing system instead of cross-bearing walls;

- iv. Simple mechanical joints between structural components, subsystem and systems.

Principles of Open Building, the independent levels of intervention and distributed control over building parts will simplify future refurbishment in two ways:

- i. Decomposition of massive structure in order to analyze the dependency conditions between elements;
- ii. Development of an integrated, flexible and demountable (IFD) systems to upgrade post-war housing on spatial, technical and environmental level.

With the building division of primary and secondary structure the designer control the envelope to ensure that redesign could fulfill the need for cultural preservation and building performance improvement, as well as providing utmost flexibility for occupants. In this way, principles of open building proved to be new opportunities for efficient ecological renovation & adaption design for industrialized post-war housing in Beograd.

B 2: Industrialized building model refurbishment scenario is based on: spatial and technical transformations; passive, active and renewable energy retrofitting. The analysis of the industrialized housing models in Beograd highlight the independent systems and components suitable for transformations. According to the flexibility of the Building Model it is possible to make changes in the dwellings. The technical, functional and energy efficiency refurbishments of the building will go in accordance with the integrated measures for the dwelling's retrofitting. We call this integration of retrofitting strategies into a refurbishment scenario. For example: an enlargement of the dwelling area and energy efficient installation systems will be integrated through the façade refurbishment.

The principal potential of the IMS building model to integrate new systems for functional and technical refurbishment, in some cases with no-demolition at all is due to the following:

- Design, composition, dimensions and location of structural components into independent functional and technical levels;
- Flexibility of the primary construction layout for flexible flats distribution. Isolation of the load-bearing assembly as an independent technical level allows a number of different layouts and customized solutions for the façade;
- Possibility to change the surface of the floor plan, either by additional construction or by changes in the boundaries of the units outside of the structural limits.

Within the above defined scope for integrated refurbishment special attention will be paid to drivers for industrialization such as: improved quality, added value for clients, process innovation versus product innovation, off-site production versus on-site production and the implementation of existing innovative systems.

New refurbishment scenarios should be planned to support a higher efficiency of the building model by increasing its transformation capacity. For this reason, the housing upgrading process for higher flexibility and adaptability of various functional and technical levels can be seen as a key integrating factor for sustainability of post-war housing. Transformable housing defines a method of construction in which an integrated load-bearing system, an HVAC system, an envelope and interior partitions that will stimulate transformations are used. The transformation capacity of more independent subsystems and components will be used for total building upgrading. Flexibility of the primary structure creates the potential for transformations on the room level and the façade level.

According to research the following integrated refurbishment scenarios have been considered suitable for post-war industrialized housing retrofitting in Beograd:

- i. **Envelope refurbishment scenario (façade and roof).** The research shows the independent façade level in the industrialized housing models. Refurbishment scenario of the envelope will include the retrofitting strategies and measures for dwellings' retrofitting.

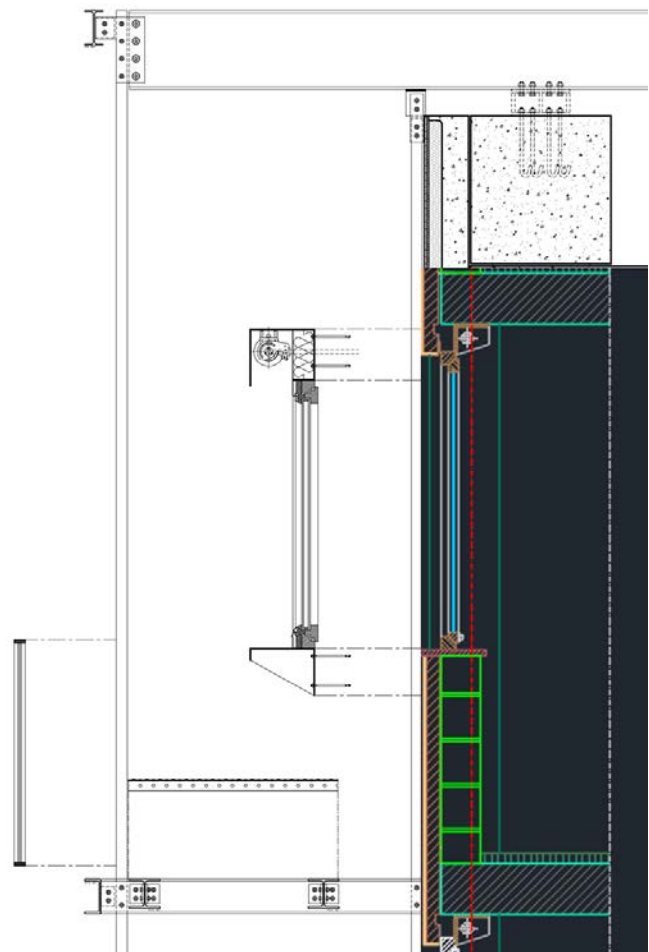

Figure 156: Refurbishment scenario of the building envelope with additional subsystems and components (windows exchange, new balconies, shading, new glazing)

According to the analysis of the industrialized housing Building Model (BM) the most appropriate adaptation strategies will be:

- **Balcony system:** A demolition of the old balconies to insulate the outside walls and then to construct completely new balconies. Big challenge is to guarantee the security for the tenants, because they will leave in the building when the balconies are broken down and the new ones are built. If the façade of a building is provided with a thermal insulation, normally the depth of balconies is reduced. In some cases (where the regulation line is not strictly ordered), the depth of the balconies will increase to 1 meters. The new balconies structure will integrate the implementation of different energy savings measures (Figure 156).
 - **New pitched roofs:** Prefabricated roof modules of solar collectors will be installed on the south facing part of the new roofs. The modules have double function: as solar collectors and as roofs. The solar collectors pre-heat domestic hot water for all apartments on the estate. Heat will be stored in the thermal mass of the original concrete facade elements. The joints between elements, which before renovation resulted in large heat losses, now will allow the warm air into the apartments. When the cooler air reaches the bottom of the wall cavity, it is returned to the solar collector to be re-heated.
 - The main energy-efficient measures for high envelope performance can be summarized: i) insulation of façades; ii) insulation of roofs; iii) insulation of top ceiling - attics; iv) insulation of the ground floor; v) new pitched roof with solar collectors; vi) renovation of the loggias and balconies; vii) renovation of the entrances; viii) double glazed windows with PVC frames.
- ii. **Infill refurbishment scenario** - The infill scenario defines a method for housing refurbishment at the dwelling level. The needs to adapt dwelling will lead the building industry towards a development of the '*infill*' technologies to support: spatial adaptation, functional changes, technical upgrading, interior comfort, etc (Figure 157). Infill systems will introduce flexibility at level IV into the edge-node relations using the modular 'kit-of-parts' systems and demountable joints. The integrated retrofitting measures will be planned on the dwelling level specially for the huge panel Building Model (BM). The development of the infill systems has to take into consideration its spatial application on one side and its technical performance on the other side, giving a greater autonomy to the individual unit. New infill scenarios for the dwellings upgrading may be developed for each dwelling independently.

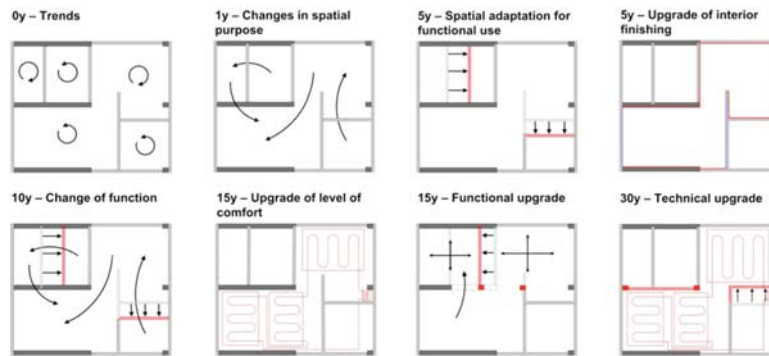

Figure 157: Functional and technical transformations of the dwelling layout (adapted from Roel Gijsberg)

- iii. **Load-bearing structure refurbishment scenario** - The adaptability of the floor plan, either by additional construction or by changes in the boundaries of the units outside of the structural limits. Dry construction and 'kit-of parts' systems are suitable for modular extension of the primary structure. This will be more suitable for the low-rise buildings, 4 up to 10 floors. The newly created spaces can be annexed to the existing structure. The expansion of dwellings may consist of building a new storey by adding attics, adding a cantilevered space, etc.
- iv. **Installation systems refurbishment scenario** - In the IMS building technology the 'holes' in cassette slab of 70x70 cm were used for the connections of the installation (walls or cabins components). The same strategy will be used for an arrangement of new installations. It is possible to make holes for the vertical shafts anywhere in the cassette slab. Making holes through the columns or floor ribs is not possible. The IMS skeleton frame of columns and "systematic" beams is considered rigid. The construction system without beams allows for the ceiling surface to conduct the installations below.
- The main refurbishment measures for high installation systems performance can be summarized: i) insulation of pipes; ii) management and control system; iii) installation of heat meters and valves; iv) new energy efficient boilers; v) mechanical ventilation with recovery; vi) renewable energy sources (solar thermal collectors, PV-systems).

This refurbishment scenarios are very close to the construction sector. The construction sector plays a key role in sustainable development. Strategies to make buildings more sustainable rely mostly on life cycle approaches for different building parts, covering the three main aspects of sustainability: environmental, economic, and social (Gervásio et al., 2014). The use of such an approach for the housing refurbishment has been identified as a decisive tool in the pursuit of sustainable construction. Major barriers to accelerated housing refurbishments are generally related to financing and ownership structures.

B 3: Industrialized, Flexible and Demountable (IFD) construction and Dry Construction principles are suitable for post-war housing refurbishment. Recent residential '*open building*' projects provide an important review of the current developments toward IFD (Industrialized, Flexible and Demountable) housing models. Figure 158 shows the load-bearing structures of industrialized housing in the last 10 years. Different industrialized and prefabricated components and subsystems have been assembled into simple and demountable joints (J. Nikolic, 2012). Flexible arrangement of the bearing elements in the building layout supports: 1) the changes in the dwellings' space; 2) the infill systems decomposition and re-assembly; 3) the possibility to extract materials for reuse or recycling.

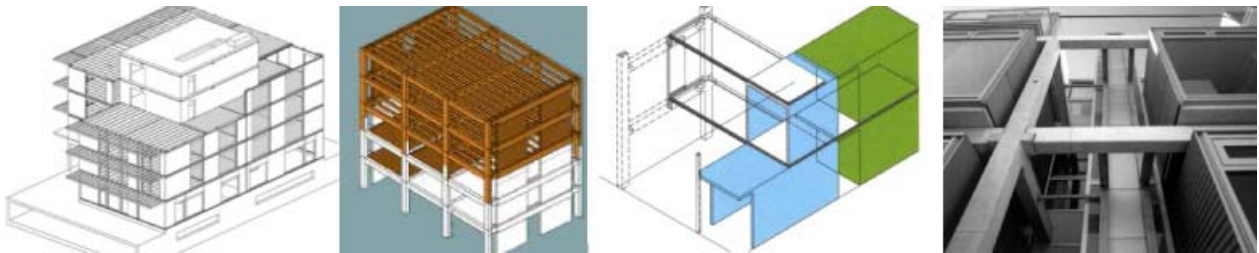

Figure 158: Integrated system configurations for the load-bearing structure: (from left to right): 2003 _ Siedlung Hegianwandweg | EM2N Architekten | Switzerland; 2012_ Collective Housing in Parma | Italy; 2005 _ "Polvori" Collective Housing | Barcelona | Spain; State of the art regarding the dynamics of change³⁷, (J. Nikolic, 2012)

A housing model based on the integration of components and subsystems into independent functional and technical levels by simple and demountable joints is suitable for transformations. Systems that have a long life span (load-bearing) are designed for flexibility and constructed for decomposition. The design and construction of flexible and demountable system configuration may extend the total building life. Load-bearing models from Figure 158 are kit-of-parts system. Kit-of-parts demountable system is a special subset of components (pre-designed / pre-engineered /pre-fabricated) and is the most appropriate for retrofitting of existing system configuration. Simple joints are applied for '*open*' assembly to support the collaboration with the construction '*in situ*'. In the IFD Kit-of-parts configuration model, different elements can be assembled and taken apart in a variety of ways. In order to achieve efficient refurbishment of housing, new conditions are needed in terms of:

- Identifying different parts of the building structure for flexible and dynamic changes to provide a variety of dwelling layouts according to the users' needs;
- Providing the systems transformations according to different life cycle of building parts;
- Treating building systems as long-term assets by decomposition and reuse;
- Upgrading of fixed function-material relations with kit-of-parts systems;
- Involving construction industry into the whole life cycle of the building and its systems.

³⁷ Rigo Research and advies BV, Een woning altijd op maat, 1999

B 4: Graph Model Report (GMR) will become part of the housing refurbishment project. We can recognize that the GM will be a valuable instrument in putting forward a method-based approach for massive housing refurbishment. According to Graph Model Reports (GMR) different types of connection have been established and analyzed to evaluate the dependency conditions between different parts in the Building Model. According to GMR the flexibility-in-use provided by an overcapacity in structure is questioned. A massive housing adaptation process results in an excessive use of resources while an extra capacity may remain unused during the lifespan of the building. Physical characteristics of the industrialized building model (construction system, assembly procedures, components, materials, and joints technology) are responsible for the post-war industrialized housing transformation capacity. Instead of demolishing the building parts for adaptability, the Graph Model maps a larger groups of interacting elements and the connections between them.

The relations between various parts have been defined by components' interface geometry and type of joint. The analysis of the massive structure through the system of joints (edges) between various systems (clusters) and components (nodes) highlighted a dependence between components and detected the flexible structural spots for the future development of refurbishment scenarios. Simple relations between nodes and clusters and demountable edges allow disassembly of the industrialized system configuration.

Evidently, every fixed connection between cluster and node is a non-desired edge in the building model. The clusters belong to a higher level in the hierarchy assembly and the node, as a single element, is at the lower level that should change more rapidly. Any fixed connection between elements that are placed in different hierarchical levels is difficult to transform. Fixed connections between two components from different levels are a problem when making changes and can end up with major demolitions and waste disposal.

Finally, different housing buildings will have different refurbishment scenarios according to dependency conditions between its structural elements, as analyzed and established in the Graph Model Report (GMR). The evaluation result will be a base to set up new integrated strategies for industrialized housing improvement through the new technologies and techniques. For that to be accomplished, both, physical and organizational complexity and permanent connections need to be overcome.

9.1 Future research

Taking into account this research project the author foresees that the future improvement of the housing transformation capacity is based on:

- i. Research to set up conditions for components compatibility and for allowing different manufactures to participate in the existing housing refurbishment. The design of components interfaces in connections is an important issue for the future industry innovations. Links between dwellings re-design, changes of service position and energy**

efficient systems installation, lead the future research to development of a new 'Infill Industry'. The idea of an 'Infill Industry' with many competitive players is the key for the future research.

- ii. **Revision to be undertaken on the currently available systems in order to maximize their outcome (especially IMS building technology). This upgrade should consider the previous experiences and adapt the IMS system according to the future needs based on the approach for more transformation capacity.**

- iii. **The IMS Complementary elements** (façade and roof panels, partitions, sanitary blocks, etc) are non-standardized elements and are defined according to the project requirements (choice of material and technical solution). In the future work we will analyze with precision complementary elements applied on existing buildings. The future development will be the new components interfaces and connections. New industrialized components will comply with a design of simple interfaces in connections and simple and dry joints. The aim is to design a typology of interfaces for the complementary elements' industry that can be applied for existing housing refurbishment scenarios. If such a typology is the answer in the future, it will comply with the Open and Sustainable Building by offering change (the interfaces are flexible). Furthermore, such a typology will increase the re-use and recycling of building model parts.

- iv. **Graph Model Report may become part of industrialized housing project documentation.** According to the graph model the existing massive housing that is "ready for demolition" will be analyzed for retrofitting. The general planning of the future research can be summarized by the following steps:
 - 1. Industrialized housing data collection in Europe (description of the building model).
 - 2. Identification of the dynamic properties of the existing structures by means of in-situ testing, observing and recording for the GM report.
 - 3. Test of structures (seismic test of a load-bearing system).
 - 4. Modeling of the original structures (using data coming from steps 2 and 3).
 - 5. Identification of the dynamic properties of the structures by means of components, subsystems and simple joints (node, cluster, edge).
 - 6. Modeling of the upgraded structures (using data coming from steps 4, 5).

- v. **Graph description language - DOT:** In the future work we will upgrade the Graph Model using **DOT (graph description language)** for faster translation of system configuration into the cluster-node-edge dependency diagram. DOT is a plain text graph description language. It is a

way of describing *graphs* - as a representation of a set of objects where some pairs of objects are connected by *links*³⁸. In our case the objects are nodes and clusters, and the links are edges.

Various programs can process DOT files. Some, like *OmniGraffle*, *dot*, *neato*, *twopi*, *circo*, *fdp*, and *sfdp*, will read a DOT file and render it in graphical form. Others, like *gvpr*, *gc*, *acyclic*, *ccomps*, *sccmap*, and *tred*, will read a DOT file and perform calculations on the represented graph. Most programs are part of the **Graphviz**³⁹ (**Graph Visualization Software**) package. *Graphviz* is a package of open-source tools for drawing graphs specified in DOT language scripts.

- **Graphviz simulation: Example with Undirected Graph Clusters**

One of the Graphviz tool that we have been applied is Undirected Graph Clusters. The layout program supports edges between nodes and clusters and cluster-to cluster (AT&T Labs Research, 2000).

An undirected graph shows simple relations between objects, such as (parapet - floor). The *graph* keyword is used to begin a new graph, and nodes are described within curly braces. A double-hyphen (--) is used to show relations between the nodes (Figure 159).

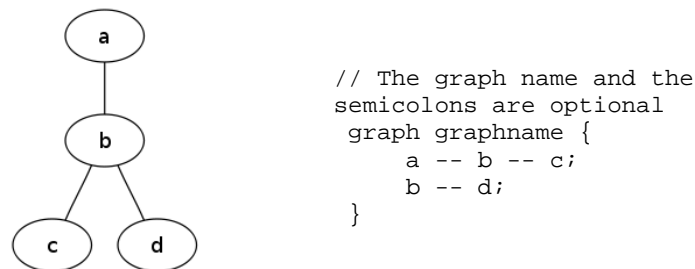

Figure 159: Undirected graphs

In Figure 160 is presented undirected graph that shows relations between:

- a, b, c, d, e, f, are nodes - elements - components; is equivalent to a column of the load-bearing structure, partition wall, or water pipe.
- A, B, C, D are clusters - components assemblies (subsystems) and are equivalent to the load-bearing structure (concrete skeleton composed of beams, columns, hollow core slabs).

³⁸ https://en.wikipedia.org/wiki/Graph_%28mathematics%29

³⁹ <https://en.wikipedia.org/wiki/Graphviz>

```

graph G {
  e
  subgraph clusterA {
    label="A"
    a -- b;
    subgraph clusterC {
      label="C"
      c -- D [penwidth=5,
color=lightblue];
    }
  }
  subgraph clusterB {
    label="B"
    d -- f [penwidth=5];
  }
  b -- d [penwidth=5, color=yellow];
  d -- D [penwidth=5.0 color=red]
  e -- clusterB [penwidth=5,
color=blue];
  clusterC -- clusterB [penwidth=5,
color=green];
}

```

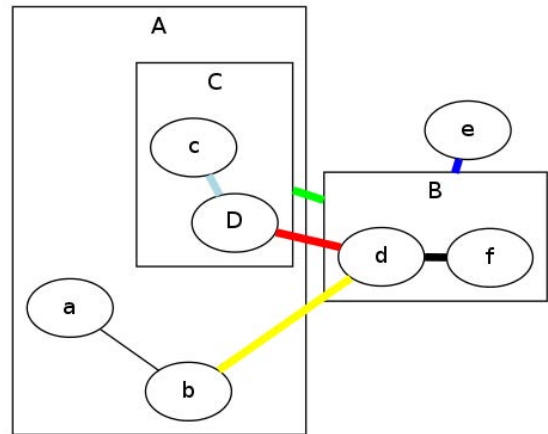

- █ CLUSTER-CLUSTER (two clusters that performs the same function)
- █ CLUSTER-NODE (cluster and node that performs different functions)
- █ CLUSTER-CLUSTER (two cluster that perform different functions)
- █ NODE-NODE (two nodes that perform the same function)
- █ NODE-NODE (two nodes that perform different functions)
- █ CLUSTER-NODE (cluster and node perform the same function)

Figure 160: Graphviz simulation: Example with Undirected Graph Clusters

In this way any change in the Industrialized Building Model (IBM) will be introduced into a Graph Model Report to control housing transformation.

10 Bibliography

- AT&T Labs Research. (2000). Graphviz - Graph Visualization Software. Retrieved from <http://www.graphviz.org/Home.php>
- Bajlon, M. (1979). *Stanovanje. Tema 1: organizacija stana*. Arhitektonski fakultet Univerziteta u Beogradu.
- Blagojevic, L. (2007). Novi Beograd: Osporeni modernizam (p. 244). Beograd: Beograd: Zavod za udzbenike, Arhitektonski fakultet Univerziteta uBeogradu, Zavod za zastitu spomenika culture grada Beograda.
- Bosma, K., Hoogstraten, D. van, & Vos, M. (2000). *Housing for the Millions : John Habraken and the SAR 1960-2000*. Rotterdam : NAI Publishers. Retrieved from http://cataleg.upc.edu/record=b1264814~S1*cat
- Braganca, L., Wetzel, C., Buhagiar, V., Verhoef, L. G. W. (2007). *COST C16 Improving the Quality of Existing Urban Building Envelopes IV - Facades and Roofs* / IOS Press. (L. G. W. Braganca, L., Wetzel, C., Buhagiar, V., Verhoef, Ed.). Delft: IOS Press under the imprint Delft University Press. Retrieved from <http://www.iospress.nl/book/cost-c16-improving-the-quality-of-existing-urban-building-envelopes-iv/>
- Brand, S. (1995). *How buildings learn : what happens after they're built*. London : Phoenix Illustrated, Quebecor Printing. Retrieved from http://cataleg.upc.edu/record=b1138147~S1*cat
- Brouwer, J., & Durmisevic, E. (2000). *Towards Dynamic Building Structures - Building with Systems*.
- Canak, M. (1970). "Funkcionalni aspekti zgrada u sistemu IMS" [Functional aspects of buildings in the IMS system. *Izgradnja, br.4*, 8–15.
- Cullen, S., Salih, N., Rashevski, M., Zigart, M., & Nikolic, J. (2015). *Integrated approach to retrofitting existing dwelling*. Belgrade.
- Diéguez-Cruz, I. R., Calderín-Mestre, F., & Ruiz-Ruiz, J. M. (2010). Structural diagnosis on IMS buildings of 18 levels in Sierra Maestra's urban center. *Revista Electrónica: Ciencia En Su PC*.
- Dimitrijevic, R., & Gavrilovic, B. (2000). *Precast prestressed concrete sceleton in contemporary building - IMS system*. Belgrade.
- Durmisevic, E. (2006). *Transformable building structures: Design for disassembly as a way to introduce sustainable engeineering to building design & construction*. (E. Durmisevic, Ed.). Cedris M&CC Leeghwaterstraat 42 2628 CA Delft, Delft, Technische Universiteit. Retrieved from http://www.4darchitects.nl/download/Transformable_building_structures.pdf
- Durmisevic, E., & Brouwer, J. (2006). *Dynamic versus static building structures*.
- Durmisevic, E., & Yeang, K. (2009). *Designing for Disassembly (DfD)*. *Architectural Design*, (202).
- Fay, R., Treloar, G., Iyer-Raniga, U., Esv, O. O. E., Willems, E., Jablonska, B., ... Autorenkollektiv. (2000). Life-cycle energy analysis of buildings: a case study. *Building Research and Information*, 28(1), 19–21. doi:10.1016/j.jclepro.2015.06.137
- Flajs, Ž. (2013). *Ispitivanje nosivosti tavanica u IMS sistemu probnim opterecenjem*. Belgrade.

- Folić, R. J., & Laban, M. Đ. (1995). Reliability and maintenance of residential buildings. *Tehnika- Nase Gradjevinarstvo*, 9–10.
- Folić, R. J., & Laban, M. Đ. (2006). Kontrola kvaliteta prefabrikovanih betonskih fasadnih elemenata nakon višegodišnje eksploatacije. In *Materijali i konstrukcije broj 1-2* (pp. 3–9). Novi Sad. doi:UDK: 692.23:624.012.3536 = 861
- Folic, R., & Laban, M. Đ. (2011). Conceptual analysis of residential buildings' facades applied in industrial building systems in Novi Sad. In *International symposium about research and application of modern achievements in civil engineering in the field of materials and structures, XXV Congress ,Proceedings (Ed. Radonjanin, V.)* (pp. 311–318). Tara. doi:ISBN 978-86-8715-02-1
- Folic, R., & Laban, M. Đ. (2012). Energy efficiency of industrially made buildings influenced by thermal properties of façades, 147–147. doi:2298/TSCI120417147L
- Gann, D. . (1996). Construction as a manufacturing process? Similarities and differences between industrialized housing and car production in Japan. *Construction Management and Economics*, 437–450.
- Gervásio, H., Santos, P., Martins, R., & Simões da Silva, L. (2014). A macro-component approach for the assessment of building sustainability in early stages of design. *Building and Environment*, 256–270.
- Gijsberg, R., Lichtenberg, J., & Erkelens, P. (2005). A new approach to flexibility-in-use: adaptability of structural elements. University of Technology, Eindhoven, The Netherlands.
- Giofrè, F., & Miletić, I. (2012). Tra passato e futuro : il Social Housing in Serbia nel processo di transizione, 61–73.
- Gregory, C. (2005). *Multispace: adaptable building design concept*. London.
- Gulvanessian, H., & Calgaro Holicky, M. (2002). *Designers' Guide to EN 1990 Eurocode: Basis of structural design*. London: Thomas Telford Publishing.
- Habraken, N. J. (2003). Open Building as a condition for industrial construction. *20th International Symposium on Automation and Robotics in Construction*, 37–42. Retrieved from <http://www.iaarc.org/publications/fulltext/isarc2003-81.pdf>
- Habraken, N. J., & Ramón, F. (1975). *Soportes : una alternativa al alojamiento de masas*. Madrid : Alberto Corazón. Retrieved from http://cataleg.upc.edu/record=b1337623~S1*cat
- Habraken, N. J., & Teicher, J. (1998). *The Structure of the ordinary : form and control in the built environment*. Cambridge, [MA] [etc.] : MIT Press. Retrieved from http://cataleg.upc.edu/record=b1147371~S1*cat
- Habraken, N. J., Wiewel, W., & Gibbons, S. (1976). *Variations : the systematic design of supports*. Cambridge, [MA] : MIT Press. Retrieved from http://cataleg.upc.edu/record=b1144155~S1*cat
- Herold, S., & Stefanovska, B. (2012). *45+ : Post-War Modern Architecture in Europe*. Berlin: Universitätsverlag der TU Berlin. Retrieved from https://www.isr.tu-berlin.de/menue/informations-_und_projektzentrum/publikationen/graue_reihe/isr_graue_reihe_43/
- IMS. (1982). *Catalogue review on variant solutions of façades in IMS building system, IMS Institute, Scientific investigation*. Beograd.
- Jablonska, B., Epema, T., Willems, E., & Visser, H. (2010). Innovative Concepts for Energy Neutral

- Districts in 2050. In *AES2010 Conference* (pp. 1–10). Barcelona, Spain. Retrieved from <http://scholar.google.com/scholar?hl=en&btnG=Search&q=intitle:Innovative+Concepts+for+Energy+Neutral+Districts+in+2050#0>
- John Habraken, N. (2008). Design for flexibility. *Building Research & Information*. doi:10.1080/09613210801995882
- Jovanović, J., Grbić, J., & Petrović, D. (2011). Prefabricated Construction in Former Yugoslavia. Visual and Aesthetic Features and Technology of Prefabrication. In *The 45+ network conference*.
- Kendall, S. (1987). Notes on Open Systems in Building Technology. *Building and Environment*, 22(2). doi:10.1016/0360-1323(87)90029-1
- Kendall, S. (1999). Open Building: An Approach to Sustainable Architecture. *Journal of Urban Technology*. doi:10.1080/10630739983551
- Kendall, S. (2014). Toward Disentanglement.
- Kendall, S., & Teicher, J. (2000). *Residential open building*. New York: E. Retrieved from http://catalog.upc.edu/record=b1166794~S1*cat
- Koprivica, B. (1970). Experiences of buiding housing by IMS construction system. *Izgradnja, br.4*, 136–146.
- Krstic -Furundzic, A. (2007). Annex of Attics on Flat Roofs of Urban Residential Buildings. In R. di Giulio, Z. Bozinovski, & L. G. W. Verhoef (Eds.), *COST C16 Improving the Quality of Existing Urban Building Envelopes: STRUCTURES* (pp. 144 – 149). Delft: IOS Press BV. doi:ISBN 978-1-58603-736-9
- Krstic -Furundzic, A., & Kopic, T. (2013). ASSESSMENT OF DIFFERENT SCENARIOS FOR ENERGY PERFORMANCE IMPROVEMENTS OF PREFABRICATED MULTIFAMILY HOUSING. In M. PUCAR, B. DIMITRIJEVIĆ, & I. MARIĆ (Eds.), *Climate change and the built environment: Policies and Practice in Scotland and Serbia (Monografija- Klimatske promene i izgradjeni prostor)* (pp. 255–281). Be: Institut za arhitekturu i urbanizam Srbije, Beograd; Glasgow Caledonian University.
- Kubet, V., Carić, O., & Hiel, K. (2010). Fleksibilnost stambene jedinice u odnosu na grupisanje instalacija. *Zbornik Radova Građevinsko-ArHITEKTONSKOG Fakulteta*, 697(045). Retrieved from <http://scholar.google.com/scholar?hl=en&btnG=Search&q=intitle:FLEKSIBILNOST+STAMBENE+JEDINICE+U+ODNOSU+NA+GRUPISANJE+INSTALACIJA#0>
- Kulic, V., & Mrduljas, M. (2012). Unfinished Modernizations: Between Utopia and Pragmatism. In *Unfinished Modernizations. Between Utopia and Pragmatism* (pp. 405–419). Udruga Hrvatskih Arhitekata. Retrieved from <http://www.erstestiftung.org/publication/unfinished-modernisations-between-utopia-and-pragmatism/>
- L. Tchervilov, N., & G. Kaloyanov, N. (2012). Study on energy efficiency in buildings in the contracting parties of the energy community - Final report, (February), 248.
- Laban, M. Đ. (2006). Quality control of prefabricated concrete façade elements after long term period of exploitation. In *Materijali i konstrukcije 49* (pp. 3–19). Novi Sad.
- Laban, M. Đ., & Folić, R. J. (2012). Energy efficiency of infudtrialy made buildings influenced by thermal properties of façades, (October), 1–16.

- Larson, K., Intille, S., McLeish, T. J., Beaudin, J., & Williams, R. E. (2004). Open source building - reinventing places of living. *BT Technology Journal*, 22, 187–200. doi:10.1023/B:BTJ.0000047598.66712.e0
- Ma, Z., Cooper, P., Daly, D., & Ledo, L. (2012). Existing building retrofits: Methodology and state-of-the-art. *Energy and Buildings*, 889–902.
- Maric, I., Nikovic, A., & Manic, B. (2010). Transformation of the New Belgrade urban tissue: Filling the space instead of interpolation. *Spatium*. doi:10.2298/SPAT1022047M
- Muravljev, M. (2010). *Branko Žeželj– stvaralaštvo inženjera i naučnika*. Beograd.
- Nascimento, D. M., & Habraken, N. J. (2012). N. J. Habraken Explains the Potential of the Open Building Approach in Architectural Practice. *Open House International*, 37(4), 5–13.
- Nijs, J. C., Durmisevic, E., & Halman, J. I. M. (2011). Interface Design for Open Systems Building. *Open House International*, 36(1).
- Nikolic, J. (2012). Development of Industrialized Flexible and Demountable multi-unit family building - IFD Collective Housing. In *AEC INTERNATIONAL CONFERENCE*. Retrieved from <http://innovationinaec2012.pcc.usp.br/>
- Nikolic, J. (2013a). New challenging approach for analysis and upgrading of massive building structure: Case study of New Belgrade post-war mega blocks. In *CESB 2013 PRAGUE - Central Europe Towards Sustainable Building 2013: Sustainable Building and Refurbishment for Next Generations* (pp. 1–10). Czech Technical University in Prague. Retrieved from <http://www.scopus.com/inward/record.url?eid=2-s2.0-84902463326&partnerID=tZOtx3y1>
- Nikolic, J. (2013b). Open Configuration Model for Collective Housing Building Structure: Graph Model. *Changing Needs, Adaptive Buildings, Smart Cities, Proceedings Book of the 39th IAHS (International Association for Housing Science) World Congress*, 71–78.
- Nikolic, J. (2014). Open configuration model for collective housing building structure: Graph model. *International Journal for Housing Science and Its Applications*, 38(3), 193–202. Retrieved from <http://www.scopus.com/inward/record.url?eid=2-s2.0-84906857378&partnerID=tZOtx3y1>
- Petrović, G., & Milovanović, N. (2012). Pilot Building as part of revitalization of IMS Building Technology in Osijek. In *iNDiS 2012 - PLANNING, DESIGN, CONSTRUCTION AND BUILDING RENEWAL* (pp. 28–30). Novi Sad.
- Phil, J., Werner, L., Jo, P., & Philipp, G. (2014). *COST Action TU1104 – Smart Energy Regions*. (J. Phil, L. Werner, P. Jo, & G. Philipp, Eds.). Bute Building, King Edward VII Avenue, CARDIFF, CF10 3NB, UK: The Welsh School of Architecture, Cardiff University.
- Pravilnik o uslovima, sadrzini i nacinu izdavanja sertifikata o enrgetskim svojstvima zgrade*. (2011). Retrieved from <http://www.kombeg.org.rs/Slike/UdrGradjevinarstvo/Statika/Informacije-zakoni/EnergetskaEfik.pdf>
- Richard, R. B. (2006). Individualization & Industrialization. In *Adaptables, TU/e, International Conference on Adaptable Building Structures*.
- Richard, R. B. (2006). *Industrialised, flexible and demountable building systems: Quality, economy and sustainability*. (Z. Y. Y. Zhao MX Feng, CC Duan,LL, Ed.).
- Savov, V. (1983). “Rad-Balency”- Huge panel prefabricated system for industrialized housing. In

- Montazni gradjevinski objekti (Prefabricated buildings)* (pp. 280–300). Belgrade: Ekonomika.
- Schneider, T., & Till, J. (2007). *Flexible housing*. Oxford: Architectural Press. Retrieved from http://catalog.upc.edu/record=b1308577~S1*cat
- Schoenborn, J. M. (2012). *A Case Study Approach to Identifying the Constraints and Barriers to Design Innovation for Modular Construction*.
- Schwieger, V., Zhang, L., & Wengert, M. (2010). Quality Model for Residential Houses Construction Processes. In *Facing the Challenges – Building the Capacity*. Sydney: Germany TS 10D.
- Serizawa, K. (2005). Development of prefabricated demountable infill system suitable for leasing and renting. In *Sustainable, World Conference, Building* (Vol. 2005, pp. 27–29).
- Šumarac, D. M., Todorović, M. N., Trišović, N. R., & Djurović-Petrović, M. D. (2010). Energy efficiency of residential buildings in Serbia. *Thermal Science*, 14(SUPPL.1), 97–114. doi:10.2298/TSCI100430017S
- T S B Consulting, E. (2007). *Roof Top Extension with prefabricated light steel elements*. Frankfurt, Germany. Retrieved from <http://www.tsb-ing.de/>
- The Construction Products Directive*. (n.d.). Retrieved from <http://eur-lex.europa.eu/LexUriServ/LexUriServ.do?uri=OJ:L:1989:040:0012:0026:EN:PDF>
- Tichem, M., Willemse, M., & Storm, T. (1995). Product Structuring and Design Coordination. In *WDK Workshop on Product Structuring*. Delft, Technische Universiteit.
- Todorović, M. S., Ilinčić, N., Martinovic, I., & Ećim, O. (2013). Building performance simulation for cost effective solar integrated refurbishment of urban residential buildings, 1–21.
- Topalović, M. (2011). *Belgrade. Formal/Informal: A Research on Urban Transformation*. Zürich: Verlag Scheidegger & Spiess.
- Topalović, M., & Kucina, I. (2010). *From planned to unplanned city: New Belgrade's transformations*.
- Trbojevic, R. (1982). “*Stambena industrijska izgradnja u Beogradu*” [*Industrial residential architecture in Belgrade*]. Belgrade: Association of Serbian Architects.
- Velkov, M., Ivkovich, M., & Perisich, Z. (1972). Experimental and analytical investigation of prefabricated large panel systems to be constructed in seismic regions.
- Waley, P. (2011). From modernist to market urbanism: the transformation of New Belgrade. *Planning Perspectives*, 26(2), 209–235. doi:10.1080/02665433.2011.550444
- Willems, E., Jablonska, B., Ruijg, G., & Krikke, T. (2011). Energy Neutral Districts? Key to Transition towards Energy Neutral Built Environment! In *World Renewable Energy Congress: Sustainable Cities and Regions (SCR)*. Retrieved from http://www.ep.liu.se/ecp/057/vol12/055/ecp57vol12_055.pdf
- Yingying, J., & Beisi, J. (2011). The tendency of “open building” concept in the post-industrial context. *Open House International*, 36(1), 6–15. Retrieved from <http://www.scopus.com/inward/record.url?eid=2-s2.0-79951864523&partnerID=tZOtx3y1>

11 List of Figures

Figure 1: Residential profile of Novi Beograd (2010 - 2013)(Todorović, Ilinčić, Martinovic, & Ećim, 2013)	2
Figure 2: Capacity to replace functionalism by standardized construction elements: Variety of spatial solutions(Stephen Kendall, 2014)	4
Figure 3: Industrialized Housing Transformation Capacity - IH-TC: Main objectives	5
Figure 4: Novi Beograd built according to 'Instructions for the Construction of Residential Buildings for the Needs of Yugoslav National army (JNA)'	10
Figure 5: Building layers according to Brand – “Sharing layers of change” (source: Stewart Brand, How Buildings learn, pp12-13, 1995)(Brand, 1995)	14
Figure 6: Structural models of post-war industrialized housing: Industrialized Precast Skeleton (IMS) construction system; Prefabricated Reinforced Concrete (RC) panel model	18
Figure 7: Combination of conventional and prefabricated systems in façade construction (Block No.21- Industrialized concrete parapet (6 cm + ceramic tiles), conventional brick parapet from the inside (19 cm))	19
Figure 8: Classification of construction building systems applied for post-war housing reconstruction in Beograd	23
Figure 9: Number of built apartments in Beograd by industrialized building systems (skeleton and panel system)(Krstic -Furundzic & Kosic, 2013)	25
Figure 10: Detail of monolithic connection: a) Joint of vertical panels and floor slabs, b) Horizontal section of vertical panels' joint, c)Vertical connection of rectangular panel walls.(Velkov, Ivkovich, & Perisich, 1972).....	26
Figure 11: Block No.64 - Rad -Balency industrialized system applied for building structure (see: Appendix - Block No.64 : Building No.04 B1)	27
Figure 12: Montastan building assembly: construction in progress	28
Figure 13: Trudbenik construction panel system: connection between façade and floor slab	28
Figure 14:Yugomont YU61 large panel system - construction work in progress	29
Figure 15: Block No. 2 - The first industrialized housing building - Corridor building (left); Slab-column post-tensioning process with steel cables (right).....	30
Figure 16: IMS housing in Cuba and Angola: building assembly process	30
Figure 17: Variety of dwelling built in IMS construction system.....	31
Figure 18: Different façade solutions: Building B9, Block No.21 (1960): Architects:Mihajlo Canak, Leonid Lenarcic, Milosav Mitic, Ivan Petrovic; Block No.28, 1974, Architect Ilija Arnautovic	32

Figure 19: Block No.2- Industrialized housing in IMS construction system- building construction in progress	35
Figure 20: Block No. 21- IMS building technology for different housing typologies.....	36
Figure 21: Block No.23 - Variety of prefabricated components applied in the façade	36
Figure 22: Block No.28 - TV buildings (IMS load-bearing construction system with "Keramzit" façade panels)	37
Figure 23: Block No.29.....	37
Figure 24: Semi-atrium building - Trudbenik prefabricated panel system (building construction in progress, see: Appendix - Block No.45 : Semi-atrium building).....	38
Figure 25: Block No. 63: Conventional reinforced concrete panel structure.....	39
Figure 26: Block No. 64: Rad-Balency huge panel industrialized system (fotos by Goran Jovanovic)	39
Figure 27: Building 'in the system': IMS Housing in Cuba.....	40
Figure 28: Block No.22- Mixed building system (see: Appendix - Block No.22: Tower Building)	42
Figure 29: Three housing variables (left); Integrated solution for spatial and technical systems flexibility (right).....	46
Figure 30: IFT integrated solution and main objective	48
Figure 31: Relations between technical and spatial systems (Source: modified from Elma Durmisevic, 2006)	49
Figure 32: NEXT 21 Technical and special system (see: Appendix - NEXT 21 Open Building experimental project).....	49
Figure 33: The Flexible Housing Primary Structure: Integrated systems for load-bearing structure	50
Figure 34: Genterstrasse_ Munich_Otto Steidle_1972: A detail of the column with the corbels (see:Appendix - Open Residential Building - best practices)	51
Figure 35: Siedlung Brombeeriweg, Zürich, Switzerland (architect: EM2N Architekten, 2003): Transformations in the dwelling unit's layout (Schneider & Till, 2007)see also:Appendix - Open Residential Building - best practices	52
Figure 36: NEXT 21 dwelling transformation: Transformations of the mayor functional end technical systems: façade perimeter, façade cladding, kitchen and bathroom position, partition walls changing position.....	53
Figure 37:: Next 21: Independent subsystems at the dwelling level: A - load-bearing module; B - envelope cladding, doors and windows; C - interior partitions, fittings, interior finishes, the doors and windows; D - dwellings' services: ducts, pipes, and wirings.; E - equipment, furniture. (Appendix - NEXT 21 Open Building experimental project)	54

Figure 38: Integrated installation systems.....	55
Figure 39: Summary of the adaptable building requirements (Gregory, 2005)	55
Figure 40: Meander building (Block No.21): Dwelling number 28 (one bedroom apartment; Original dwelling layout (left); functional transformations- current state (right)).....	57
Figure 41: Dwelling number 28 (one bedroom apartment): Original dwelling layout (left); functional and structural transformations- current state (right).....	58
Figure 42: Installation block: Existing installations (red line); possibility of relocation of installations (blue line).	58
Figure 43: The best practices of Open Residential project: Flexible layout of the load-bearing structure (see: Appendix - Open Residential Building - best practices)	60
Figure 44: Closed versus open system configuration (source: OBOM, 1997): A, B, C, D, E are independent systems.....	61
Figure 45: The IMS skeleton assembly process: Corridor building in Block No.2	62
Figure 46: The IMS system axonometric of load-bearing components: concrete column, pre-stressed slabs, corner slab, edge rib (Petrović & Milovanović, 2012)).....	63
Figure 47: Systematization of the building parts according to independent technical and functional levels	64
Figure 48: Different building layouts: Changes of the exterior perimeter of the building layout and building envelope, Tower building in Block No. 70 (source: Historical Archives of New Belgrade)	65
Figure 49: The Graph Model defined by Node, Edge, Cluster, and System (J. Nikolic, 2014).....	66
Figure 50: Different types of edges in the system configurations: cluster-cluster; cluster-node; node-node (from left to right), (IMS, 1982).....	67
Figure 51: Systematization of building parts (Tichem, Willemse, & Storm, 1995) - right, left: Wood constructive system, (Parma, Italy, 2012)- left	68
Figure 52: Graph Model of structural elements in IMS system configuration (J. Nikolic, 2014).....	69
Figure 53: Building model composition: division and subdivision of systems in industrialized housing building	71
Figure 54: A systematic approach according to independent functional and technical levels	72
Figure 55: Reinforced concrete strip foundation.....	73
Figure 56: IMS composite panel solution and corresponding U values (Folic & Laban, 2012) A : Prefabricated panel: 1. concrete 6 cm; 2. EPS (expanded polystyrene) 6 cm, 3. concrete 8 cm; 4. mortar 1.5 cm; B : Semi-prefabricated ventilated façade: 1. precast concrete 8 cm; 2. EPS 6 cm; 3. brick 12.5 cm; 4. mortar 1.5 cm.	74

Figure 57: Typology and classification of the prefabricated façade elements in the IMS (Folic & Laban, 2011)	75
Figure 58: Full storey high façade precast element, (IMS, 1982).....	75
Figure 59: Multilayer parapet panel - panel-floor joint, (IMS, 1982).....	76
Figure 60: Systematization of components in IMS system configuration (J. Nikolic, 2014)	77
Figure 61: Systematization of industrialized components and subsystems into independent levels.....	78
Figure 62: Functional flexibility of the dwelling layout in the IMS modular grid 4.2 x 4.2 m (Canak, 1970)	79
Figure 63: Schematic representation of types of façade panels and system of joints in the IMS system (IMS, 1982)	79
Figure 64: Column-slab joint in IMS Building Technology. Top-view of the standard	82
Figure 65: Block No.1: Tower and condominium buildings - Different functional and technical levels ...	82
Figure 66: Block No.1, building A: The IMS Building Model (the load-bearing structure and (red); envelope (blue); interior partitions (green); installations (blue)).....	83
Figure 67: Systematization of the IMS Building Model according to the independent technical levels: IMS-PS (primary structure); IMS-SS (secondary structure).....	83
Figure 68: A building model decomposition into main functional and technical levels: load-bearing, façade, partitions and services.....	84
Figure 69: Graph Model for housing building in Block No.1: PF - primary frame (slab-column frame); CC – concrete column; CS – concrete slab; SsW –shear wall; SF – secondary frame (cantilever structure); Sc – staircases; Cs – cantilever slab; EG – edge girder, ENVELOPE : EC – exterior cladding; ES – envelope sheet – sandwich parapet wall; WF – windows frame; PW – parapet wall; A - air chamber; BP – balcony parapet; L – loggia; INFILL : IP – interior partition wall; SCF – suspended ceiling frame; CF – ceiling finishing; IWF – interior wall finishing; Aa - acoustic isolation, ROOF : RS – roof slab; RA - roof attic; Ti – thermal insulation layer; Hi – hydro insulation layer; Ai - acoustic isolation, SERVICES : WS – water supplies, pipes and ducts; GS – gas supplies; EC – electricity wires; IW – installation walls.	84
Figure 70: The connection between edge girder and loggia parapet (EG - Pw.)	85
Figure 71: Shear wall connection details	86
Figure 72: Interior division of the building layout - position of the partition walls(see: Appendix - Block No.2: Tower and Condominium building).....	87
Figure 73:: Installations cores and corresponding dwelling area (left); possible transformations (right)...	88
Figure 74:: A building model decomposition into main functional and technical levels: load-bearing, façade, services and partitions.....	88

Figure 75: The load-bearing layout of tower building B+14: Typical floor plan and foundations	89
Figure 76: A typical floor plan (left); A two-bedroom dwelling unit(right)	89
Figure 77: Façade panel section: Connections detail with a roof (cornice components-left) and floor slab-right	90
Figure 78: Installations' wall with ventilation canals specified for different flats height.....	90
Figure 79: Building Model: Load-Bearing structure.....	91
Figure 80: A typical floor plan and dwelling types(see: Appendix - Block No.21 : Meander building)....	91
Figure 81: Rows of parapets and windows façade model (see: Appendix - Block No.21 : Meander building)	92
Figure 82: Pw - S connections: Mechanical joint of the IMS façade panel and slab (left); Detail of joints PW-EG (parapet wall – edge girder) - right;	93
Figure 83: Industrialized prefabricated IMS component for parapet wall	93
Figure 84: Building B9 - Composite façade structure- fixed and mechanical joints	94
Figure 85: Block No.63 - Building No.06 B2(see:Appendix - Block No.63 : Building No.06 B2)	94
Figure 86: Graph Model for the building No. 06B2 in Block 63	95
Figure 87: Prefabricated panel cladding and joint with floor slab	96
Figure 88: Atrium building: Building process in progress and finished building model (see:Appendix - Block No.45 : Semi-atrium building).....	96
Figure 89: Balcony structure: Range of applied components (colored elements are industrialized components)	97
Figure 90: Block No.62, Building A1 (06/62): Independent building levels.....	97
Figure 91: New Belgrade-City of Housing: Block No. 64 (foto by Goran Jovanovic).....	98
Figure 92: Graph Model - Rad-Balency system.....	98
Figure 93: Block No. 64: Building model - Rad-Balency system(above); Joint detail of façade panel and interior partition (left); cross section (right) - (see: Appendix - Block No.64 : Building No.04 B1).....	99
Figure 94: IMS building technology: Minimal social dwelling versus luxurious apartments.	101
Figure 95: A view of the characteristic housing layouts in IMS modular grid 420/420 cm (Canak, 1970)	101
Figure 96: Different dwellings arrangement in the IMS building model (red color - load-bearing system)	103
Figure 97: Block No.2: Condominium housing - Building Model decomposition	103
Figure 98: Dwellings disposition around vertical communications in tower buildings	104

Figure 99: Block No. 21:Meandar building typical floor plan.....	104
Figure 100: One-bedroom apartments (one and a half bedroom), (Canak, 1970).....	105
Figure 101: Two and a half bedroom apartment, (Canak, 1970)	105
Figure 102: Two and a half bedroom apartment with the circular room disposition (left); Two bedroom apartment with the one direction communication (right), (Canak, 1970)	106
Figure 103: Circular communication in the dwellings (Canak, 1970)	106
Figure 104: Kitchen and dining room derived from the entrance corridor, (Canak, 1970).....	106
Figure 105: Components assembly: From dependent conditions to systematic hierarchy assembly.....	107
Figure 106: Disassembly hierarchy and relational diagram: Left: Transformable configuration; right: Permanent configuration - lack of transformation potential (Durmisevic, 2006)	108
Figure 107: Balcony and loggia transformations - (Block No.21, Building B9): foto by Sonja Jurosevic	113
Figure 108 : Windows' replacement: Northeastern façade (above); Southwestern façade (bellow).....	114
Figure 109: Joint between column, slab and parapet element: presence of thermal bridge	114
Figure 110: Regulations for envelope thermal performance from the 60'(Folić & Laban, 1995)(Folić & Laban, 2006).....	116
Figure 111: Block No. 23: Dilapidated façade panel with visible damage: Loss of concrete section. Steel exposed to the presence of corrosion; steel section loss; cracking of the concrete.	118
Figure 112: Balcony and parapet structure (see: Appendix - Block No.21 : Meander building).....	122
Figure 113: Variations of façade solution in the IMS buildings: Thermal conditions (Laban & Folić, 2012). A: Prefabricated panel and parapet: 1. Concrete 6 cm; 2. EPS (expanded polystyrene) 6 cm, 3. Concrete 8 cm; B: Semi-prefabricated ventilated façade: 1. Prefabricated concrete casing 6 cm; 2. Layer of air 2 cm; 3. EPS 6 cm; 4. Brick 6.5 cm; 5. Compo mortar 1.5 cm; C: Lightweight ventilated façade: 1. Asbestos cement sheeting 1 cm; 2. Layer of air 2 cm; 3. EPS 6 cm; 4. Brick 6.5 cm; 5. Compo mortar 1.5 cm; D: Semi-prefabricated façade with face brick casing: 1. Perforated face bricks 12 cm; 2. EPS 4 cm; 3. Reinforced concrete 8 cm; E: Traditionally built façade: 1. Perforated face bricks 12 cm; 2. EPS 2 cm; 3. Perforated concrete block 20 cm; 4. Compo mortar 1.5 cm.....	123
Figure 114: Detail of the parapet façade (vertical and horizontal section)- see: Appendix - Block No.21 : Meander building,	124
Figure 115: Energy needs for heating per month: current situation.....	126
Figure 116: Energy need/losses for heating per month and per m ² of dwelling area (Appendix - Energy needs for heating: Parapet façade).....	126
Figure 117: A different solution for the IMS building model: TV Building Block No. 28	127

Figure 118: Industrialized prefabricated "Keramzit" panel (Koprivica, 1970)	127
Figure 119: Technology of joints: a detail of joint between "Keramzit" panel and an edge girder (Koprivica, 1970)	128
Figure 120: Radomir 2 massive housing block (Bulgaria): Before and after renovation.....	130
Figure 121: Linz (Austria): Integrated refurbishment scenario.....	130
Figure 122: Main categories of building retrofit technologies (Ma et al., 2012)	132
Figure 123: Annex of balconies and thermal refurbishment of the envelope ("Square Vitruve" social housing, see: Appendix - Refurbishment scenarios for post-war housing in Europe: State-of-the-art)....	133
Figure 124: Annex of attics on the top of the flat roofs: Three-story block in Praunheim, a district of Frankfurt am Main(T S B Consulting, 2007), see: Appendix - Refurbishment scenarios for post-war housing in Europe: State-of-the-art	134
Figure 125: Residential area of Markbacken in Örebro, Sweden: a) The bottom floor before and after merging the flats; b) the floor plan before and after the addition of a lift; c) enlarging the balconies; d) The addition of staircases. (see: Appendix - Refurbishment scenarios for post-war housing in Europe: State-of-the-art)	135
Figure 126: The Franz-Stenzer Building Block - Marzahn, Berlin: a) new floor plans vs. old; b) a construction principle for making a breakthrough; c) removing the bearing façade elements (horizontal and vertical sections); d) a steel construction for four winter gardens; e) a principle of concrete extension; f) removing (parts of) floor elements; g) execution varieties of breakthroughs in the load-bearing façade elements	135
Figure 127: Seven principles of connections, ranged from fixed to flexible (Durmisevic, 2006)	137
Figure 128: Matrix tile mockup and matrix tile system	138
Figure 129: Composition using demountable interface (left); Attachment of demountable interface (right)	138
Figure 130: Hanged pipes on the floor - left; Plane of the floor panels and pipes - right, (Serizawa, 2005)	139
Figure 131: Building energy rating is an indication of the energy performance of the building (the last column are references for the existing buildings)	140
Figure 132: Model M1 (left); Model M2(right), see: Appendix - Energy needs for heating: Parapet façade	142
Figure 133: Energy needs for heating QH,nd: Different models' results	143
Figure 134: Energy need for heating per month according to three refurbishment models: 1- Current situation of the envelope; 2 - window exchanging scenario; 3 - thermal improvement scenario; 4 - windows replacement and thermal improvement - integrated approach.....	143

Figure 135: Refurbishment scenario of the building envelope with additional subsystems and components (windows exchange, new balconies, shading, new glazing)	144
Figure 136: Solutions for the thermal bridge break in the joints: D1 (window-column); D2 (windows - partition wall); D3 (window - parapet); D4 (window- floor slab).....	145
Figure 137: Attics annex at Uciteljsko naselje - attic construction made of wooden trussed girders	147
Figure 138: Attics annex at Miljakovac settlement (Krstic -Furundzic, 2007)	148
Figure 139: Housing in Konjarnik: Typical floor plan and façade	148
Figure 140: Attics annex at Konjarnik settlement.....	149
Figure 141: Integrated refurbishment scenario	150
Figure 142: Integrated refurbishment strategies.....	150
Figure 143: Meander building: three dwellings per stairs experimental module	151
Figure 144: Energy consumption before and after envelope thermal retrofitting (heating-red line, cooling-blue line, solar gains-yellow line)	152
Figure 145: Temperature and heat losses (Cullen, Salih, Rashevski, Zigart, & Nikolic, 2015)	153
Figure 146: CO ₂ emissions	153
Figure 147: Renewable retrofitting scenario	154
Figure 148: PVGIS estimates of solar electricity generation (see: Appendix - Photovoltaic Geographical Information System (PVGIS) simulation of the performance of PV system).....	155
Figure 149: Annual consumption and production(see: Appendix - Energy need for heating (200m ² module): Consumption and Production balance)	156
Figure 150: Mechanical ventilation with heat recovery	157
Figure 151: Detail of the light-weight new attic construction (Appendix - Refurbishment scenarios for post-war housing in Europe: State-of-the-art).....	158
Figure 152: Systematic integration of energy efficient 'measures': TSE_ thermal solar energy; PHSE_ photovoltaic solar energy; SP_ solar protections; NI_ natural illumination; TI_ thermal isolation; VF_ ventilated façade; GE_ geothermal energy; IAD_ industrialization, assembly, disassembly; VI_ vegetation installation; RS_ rainwater storage; GWR_ grey-water reuse; NV_ natural ventilation; CV_ crossed ventilation; TS_ thermal storage; AI_ acoustic isolation; etc.....	161
Figure 153: Systematization of components according to base element and hierarchy assemblies.....	162
Figure 154: IMS System 50: Industrialized Building Model	163
Figure 155:: Demountable connection between cantilever slab and loggia parapet (EG - PW1).....	163
Figure 156: Refurbishment scenario of the building envelope with additional subsystems and components (windows exchange, new balconies, shading, new glazing)	166

Figure 157: Functional and technical transformations of the dwelling layout (adapted from Roel Gijsberg)	168
Figure 158: Integrated system configurations for the load-bearing structure: (from left to right): 2003 _ Siedlung Hegianwandweg EM2N Architekten Switzerland; 2012_ Collective Housing in Parma Italy; 2005 _ ”Polvori” Collective Housing Barcelona Spain; State of the art regarding the dynamics of change , (J. Nikolic, 2012)	169
Figure 159: Undirected graphs	172
Figure 160: Graphviz simulation: Example with Undirected Graph Clusters	173

12 List of Tables

Table 1: Structure of dwelling types: S-studio; 1-one bedroom flat; 1.5-one and half bedroom flat; 2-two bedrooms flat; 2.5-two and a half bedrooms flat; 3- three rooms flat; 4-four rooms flat	36
Table 2: Characteristic of the System 50 Building Model	80
Table 3: Degradation of construction elements in IMS Building Model (Flajs, 2013)	115
Table 4: Common defects in façades due to the different causes	118
Table 5: U value of different envelope elements	125
Table 6:: Annual heating needs (see: Appendix - Energy need for heating (200m ² module): Consumption and Production balance)	156

APPENDIX

13 Appendix - Open Residential Building - best practices

14 Appendix - NEXT 21 Open Building experimental project

15 Appendix - Block No.2: Tower and Condominium building

16 Appendix - Block No.21 : Meander building

17 Appendix - Block No.21 : Building B9

18 Appendix - Block No.22: Tower Building

- 19 Appendix - Block No.45 : Semi-atrium building**
- 20 Appendix - Block No.63 : Building No.06 B2**
- 21 Appendix - Block No.64 : Building No.04 B1**
- 22 Appendix - Energy needs for heating: Parapet façade**
- 23 Appendix - Energy need for heating (200m² module): Consumption and Production balance**
- 24 Appendix - Photovoltaic Geographical Information System (PVGIS) simulation of the performance of PV system**
- 25 Appendix - Refurbishment scenarios for post-war housing in Europe: State-of-the-art**